

CHECK DAMS

APPLICATION NOTES:

- A. THE PRIMARY PURPOSE OF A CHECK DAM IS TO REDUCE EROSION IN A CHANNEL BY REDUCING FLOW VELOCITY.
- B. CHECK DAMS WILL CAPTURE SEDIMENT THAT FALLS OUT OF SUSPENSION BEHIND THE CHECK DAM DUE TO DECREASED VELOCITY.
- C. CHECK DAMS ARE NOT INTENDED TO FILTER SEDIMENT FROM TURBID WATER.
- D. DETAILS SHOWN SHALL BE USED FOR TEMPORARY INSTALLATION ONLY.
- E. PREFABRICATED DAMS ARE NOT TO BE USED ON SLOPES GREATER THAN 5% OR PER MANUFACTURER'S SPECIFICATIONS.
- F. PREFABRICATED DAM SPECIFICATIONS SHALL BE PROVIDED TO THE ENGINEER FOR APPROVAL PRIOR TO USE.

GENERAL NOTES:

1. GEOTEXTILE SHALL BE INSTALLED UNDER STONE FILL. IT SHALL BE KEYED IN ON THE UP HILL END AND SHALL EXTEND 2 FEET BEYOND THE STONE ON THE DOWN HILL END.
2. CORE MATERIAL FOR THE STONE CHECK DAM SHALL MEET THE GRADATION REQUIREMENTS OF STONE FILL TYPE I (MIN.). STONE SIZE SHOULD BE INCREASED WITH INCREASED SLOPE AND VELOCITY.
3. THE UPHILL END OF THE APRON FOR THE PREFABRICATED CHECK DAM SHALL BE STAPLED AND BURIED AS SHOWN IN DETAIL 'A' OR AS RECOMMENDED BY THE MANUFACTURER'S LITERATURE.
4. MEASURES SHALL BE INSPECTED EVERY SEVEN (7) CALENDAR DAYS AND WITHIN 24 HOURS OF A STORM EVENT GREAT ENOUGH TO CAUSE WATER TO LEAVE THE CONSTRUCTION SITE.
5. MEASURES SHALL BE CLEANED AND REPAIRED AS NEEDED. SEDIMENT SHALL BE REMOVED WHEN ACCUMULATION REACHES ONE-HALF OF THE MEASURE HEIGHT. SEDIMENT SHALL BE DISPOSED OF AS UNSUITABLE MATERIAL.
6. AT TIME OF REMOVAL OF THE CHECK DAMS, THE DISTURBED AREA SHALL BE REPAIRED AND STABILIZED.
7. PAYMENT FOR INSTALLATION AND REMOVAL OF CHECK DAMS SHALL BE MADE UNDER APPLICABLE ITEMS INCLUDED IN THE CONTRACT PLANS OR UNDER THE FIELD MAINTENANCE OF EROSION & SEDIMENT CONTROL PLAN ITEM.
8. PAYMENT FOR MONITORING CHECK DAMS SHALL BE MADE UNDER THE MONITORING EROSION & SEDIMENT CONTROL PLAN ITEM.
9. PAYMENT FOR MAINTAINING CHECK DAMS SHALL BE MADE UNDER THE FIELD MAINTENANCE OF EROSION & SEDIMENT CONTROL PLAN ITEM, UNLESS MAINTENANCE IS REQUIRED DUE TO POOR INSTALLATION PRACTICES.

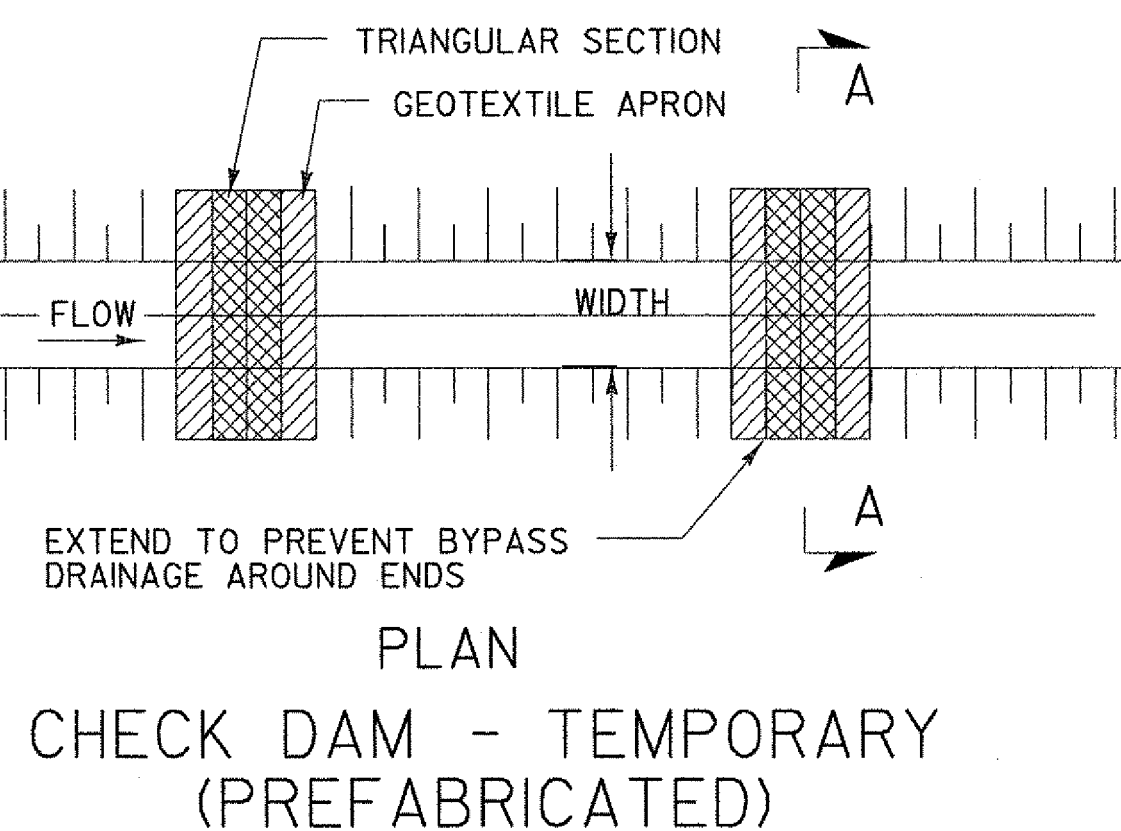
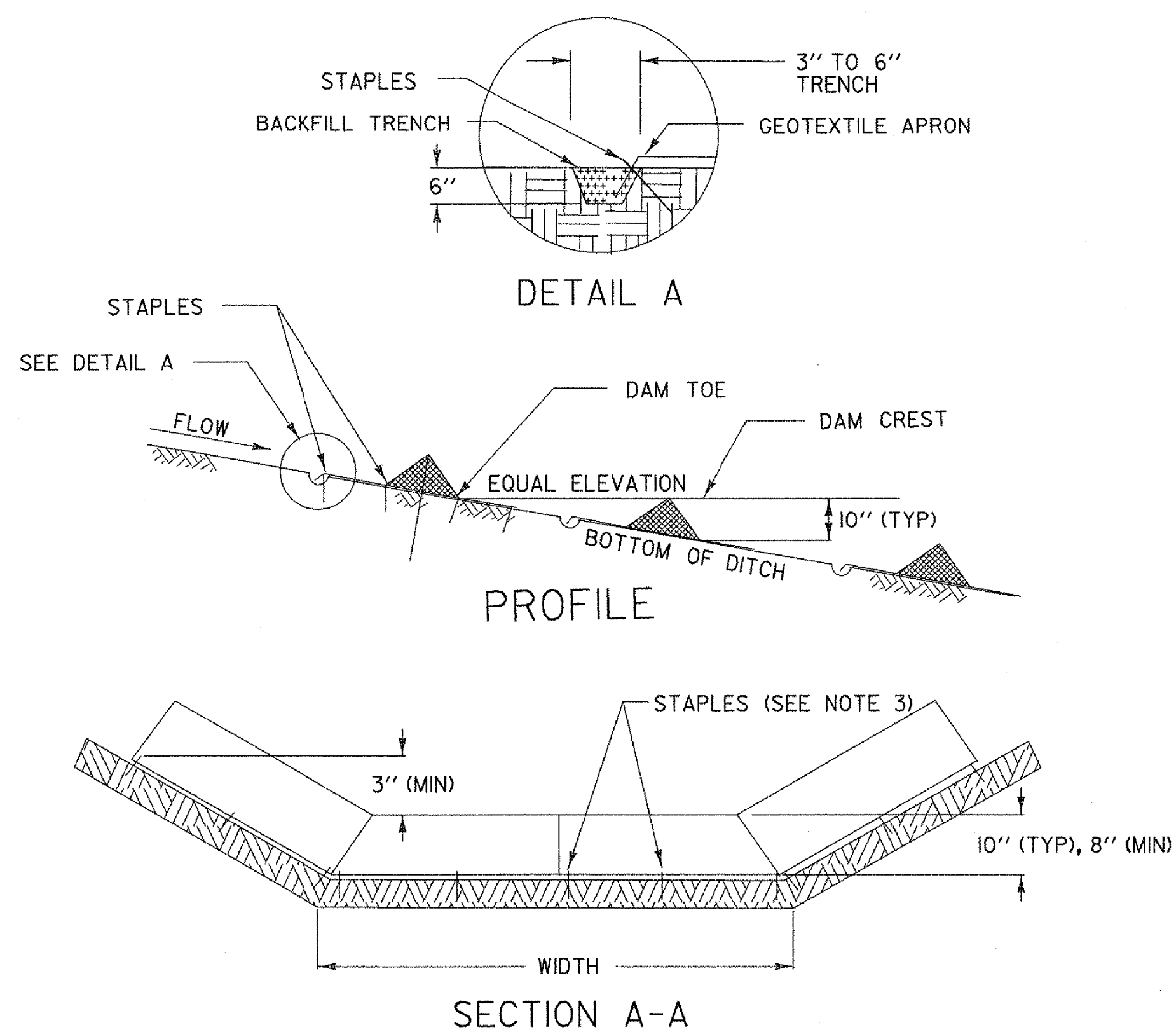

DITCH SLOPE	PLACEMENT INTERVAL **
1 %	50 FT
2 %	40 FT
3 %	25 FT
4 %	20 FT
5 %	15 FT

** BASED ON 10" TYPICAL HEIGHT

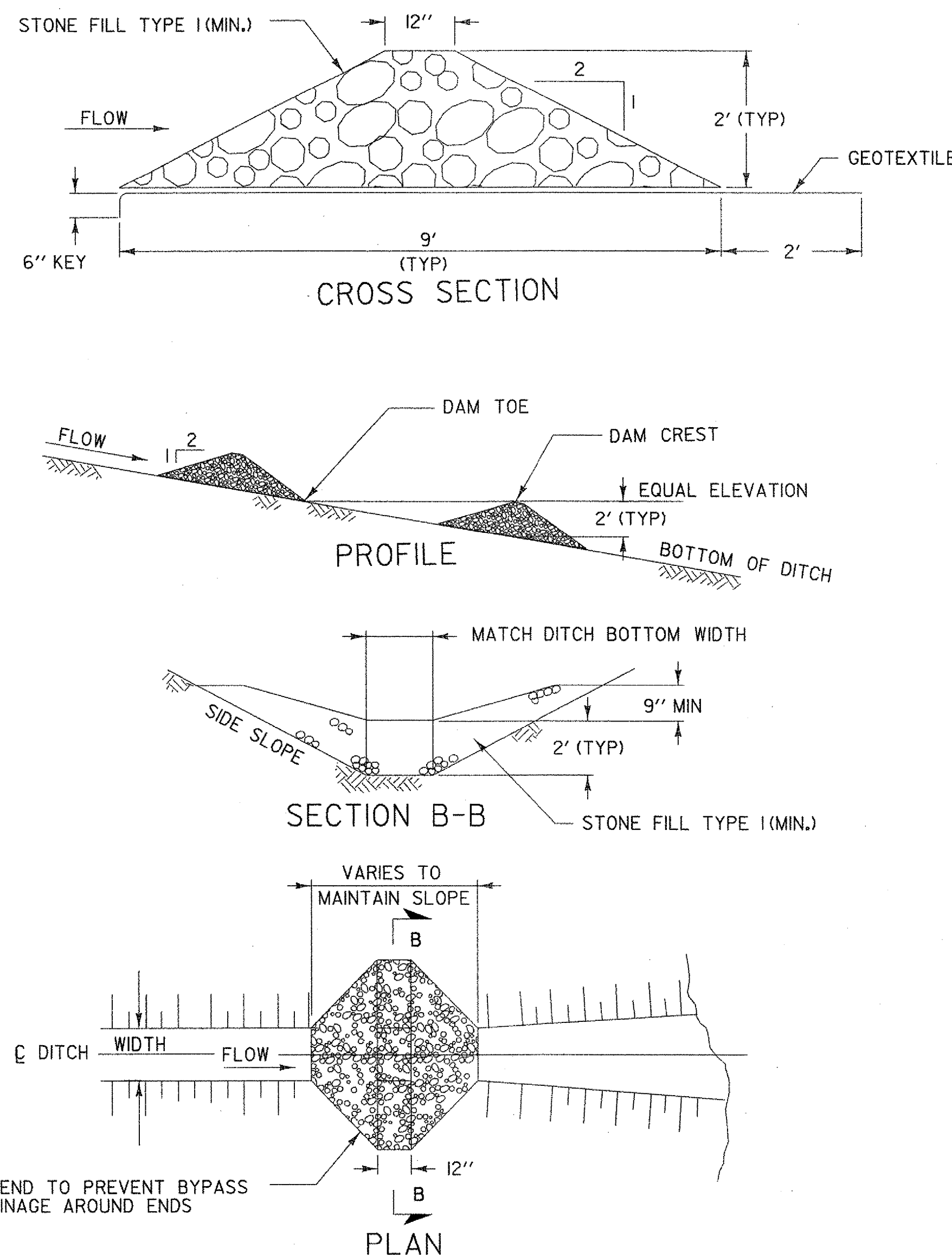

DITCH SLOPE	PLACEMENT INTERVAL **
1 %	200 FT
2 %	100 FT
3 %	65 FT
4 %	50 FT
5 %	40 FT
6 %	30 FT
8 %	25 FT
10 %	20 FT

** BASED ON 2' TYPICAL HEIGHT

REVISIONS AND CORRECTIONS
MAY 18, 2004 N. GARBACK

DETAIL
EPSC-2

EROSION PREVENTION & SEDIMENT CONTROL DETAILS CHECK DAMS

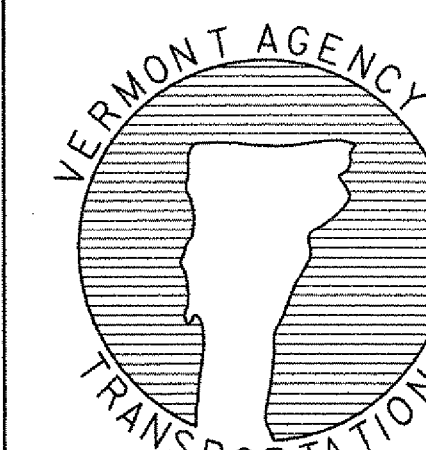

STATE OF VERMONT AGENCY OF TRANSPORTATION	
Town Of WOODSTOCK	Bridge No. 50
Highway No. U.S. ROUTE 4	Log Sta. Surv. Sta.
U.S. ROUTE 4 OVER OTTAUQUECHEE RIVER	
EPSC-2	
Designed By VTRANS	Drawn By B. J. MASSE
Checked By VTRANS	Bridge Design Supervisor M. A. COLGAN Date 9/05
PROJECT WOODSTOCK	PROJECT NO. BHF-020-2 (32)
I.G.C. Info.	
Bridge Sheet No. ZJ028EPSC-2	Sheet 62 of 71