

**CONDITION 1
DROP-OFF ADJACENT TO TRAVELLED-WAY**

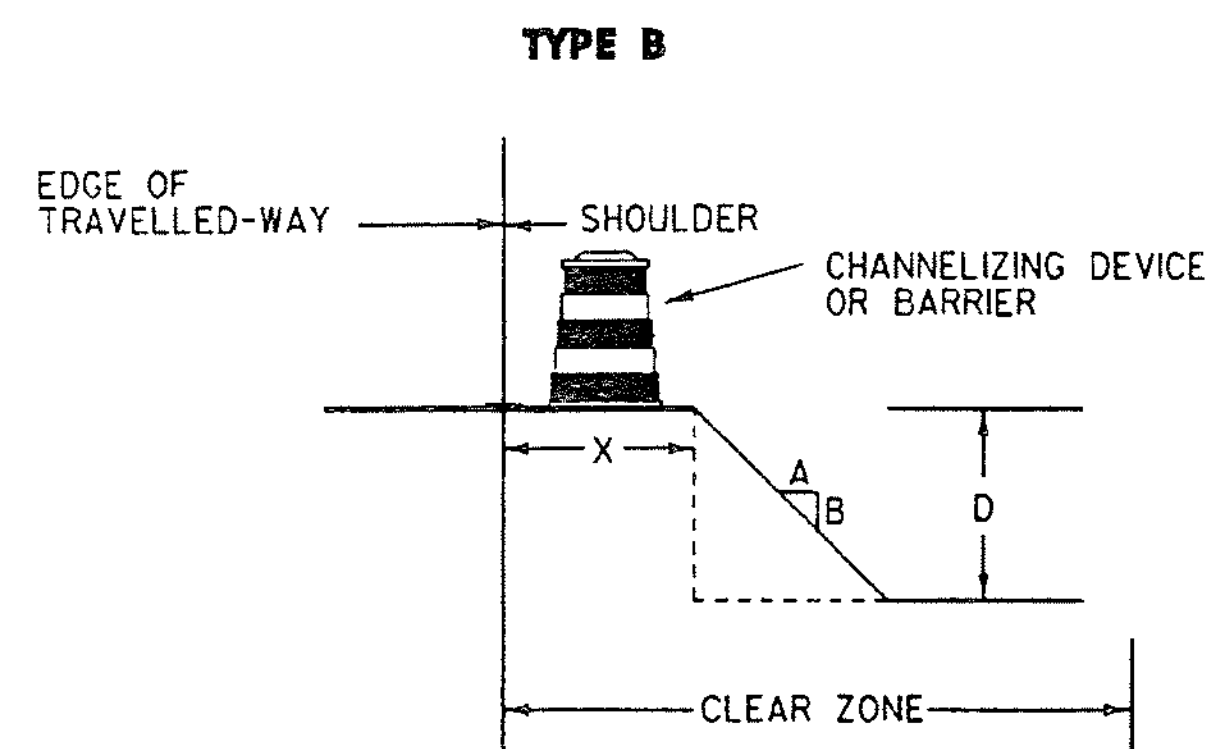

- NOTES:**
- CHANNELIZING DEVICES OR BARRIER SHOULD BE PLACED TO MAXIMIZE THE WIDTH OF THE TRAVELED-WAY.
 - FOR SPECIFIC REQUIREMENTS USE CHART "A".
 - IF THE DROP-OFF REQUIRES CHANNELIZING DEVICES TO REMAIN IN PLACE OVERNIGHT THEN "LOW SHOULDER" OR "SHOULDER DROP OFF" SIGNS SHOULD BE INSTALLED.

**CONDITION 2
DROP-OFF BETWEEN ADJACENT TRAVELLED LANES**

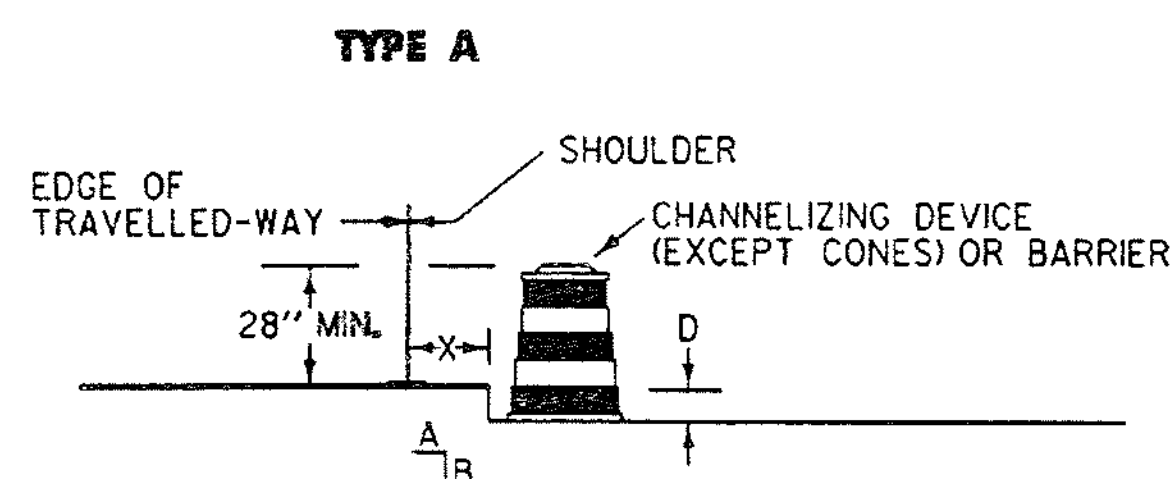
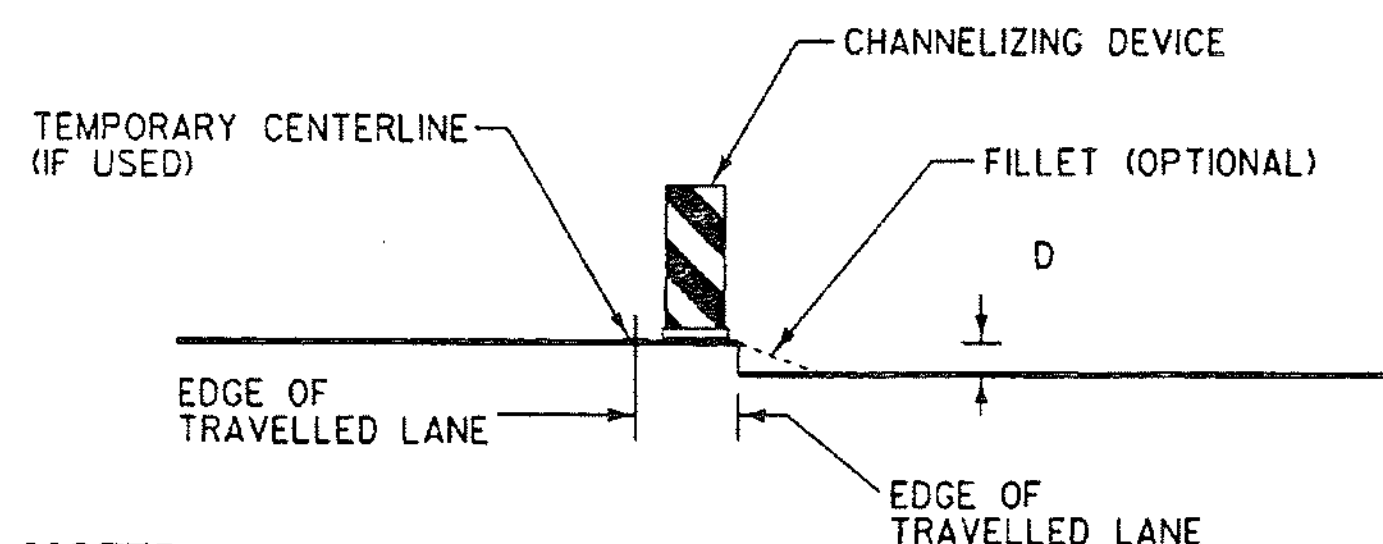

- NOTES:**
- WHENEVER A LONGITUDINAL DROP-OFF BETWEEN ADJACENT TRAVELLED-LANES IS TO BE LEFT OVERNIGHT THEN "UNEVEN LANES" SIGNS AND CHANNELIZING DEVICES SHOULD BE INSTALLED.
 - IF REQUIRED, THE CHANNELIZING DEVICES USED SHOULD BE THOSE WHICH MAXIMIZE THE TRAVELLED LANE (IE. CONES, VERTICAL PANELS OR TUBULAR MARKERS).
 - A BITUMINOUS CONCRETE FILLET WITH A 3:1 SLOPE MAY BE USED IN LIEU OF CHANNELIZING DEVICES, HOWEVER THE "UNEVEN LANES" SIGNS SHOULD BE INSTALLED REGARDLESS.

**CONDITION 3
DROP-OFF BEYOND SHOULDER OR CURB**

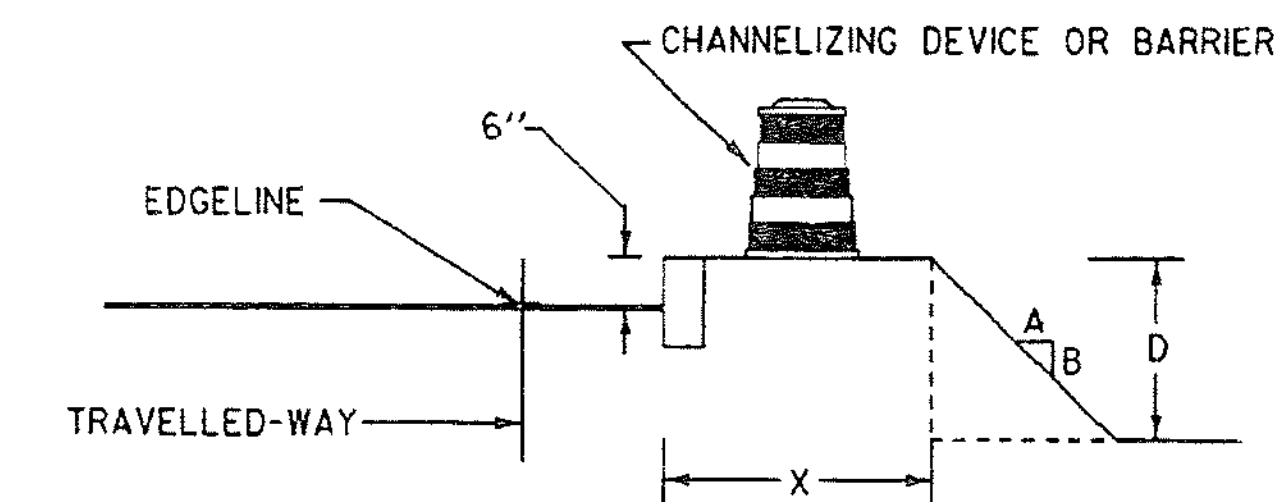

- NOTES:**
- CHANNELIZING DEVICES OR BARRIER SHOULD BE PLACED TO MAXIMIZE THE WIDTH OF THE TRAVELLED WAY.
 - FOR SPECIFIC REQUIREMENTS USE CHART "A" OR "B" AS APPLICABLE.

**CHART A
ALL SPEEDS
NO CURB**

X (FEET)	DROP (D) (INCHES)	A/B SLOPE	DEVICE REQUIRED
0 TO 4'	LESS THAN 2"	ANY	NONE
	2" TO 5"	3:1 OR FLATTER	NONE
		STEEPER THAN 3:1	CHANNELIZING DEVICE
4' TO 10'	LESS THAN 5"	ANY	NONE
	5" TO 12"	3:1 OR FLATTER	NONE
		STEEPER THAN 3:1	BARRIER
10' TO CZ	LESS THAN OR EQUAL TO 12"	ANY	NONE
	GREATER THAN 12"	3:1 OR FLATTER	NONE
		STEEPER THAN 3:1	BARRIER

- CLEAR ZONE (CZ) IS TO BE DETERMINED PER THE CURRENT AASHTO ROADSIDE DESIGN GUIDE.
- CHANNELIZING DEVICES MAY BE USED INSTEAD OF BARRIER FOR SHORT TERM (ONE-DAY) OPERATIONS.
- ON BORDERLINE CONDITIONS THE ENGINEER SHALL DETERMINE WHICH TREATMENT IS ADEQUATE FOR THE EXISTING CONDITIONS.

GENERAL NOTES

- THESE CONDITIONS AND TREATMENTS ARE ONLY PART OF THE TRAFFIC CONTROL SYSTEM AND SHALL BE USED IN ADDITION TO THE PROPER WORK ZONE SIGNING.
- THE FOLLOWING ARE ACCEPTABLE CHANNELIZING DEVICES: SEE STANDARD SHEETS E-106, E-107 AND E-107A FOR FURTHER DETAILS.
 - A. VERTICAL PANEL
 - B. TYPE I OR TYPE II BARRICADE
 - C. PLASTIC DRUM
 - * D. CONE - WHERE APPLICABLE

* CONES SHALL NOT BE USED WHEN THE CHANNELIZING DEVICE IS REQUIRED TO BE PLACED BELOW THE GRADE OF THE TRAVELLED-WAY. (SEE CONDITION 1, TYPE A)
- WHERE BARRIER IS CALLED FOR, EITHER CONCRETE BARRIER (JERSEY SHAPE), STEEL BEAM GUARDRAIL OR OTHER FHWA APPROVED BARRIER MAY BE USED.
 - BARRIER ENDS FACING ONCOMING TRAFFIC SHALL BE TAPERED BEYOND THE CLEAR ZONE OR PROTECTED WITH AN APPROVED END TREATMENT DESIGNED FOR THE 85TH PERCENTILE SPEED OR THE POSTED SPEED LIMIT OF THE ROADWAY.
- CHANNELIZING DEVICE SPACING SHALL BE AS FOLLOWS:
 - TAPERS - CHANNELIZING DEVICES SHALL BE SPACED A MAXIMUM OF 'S' (THE SPEED LIMIT IN FEET, 65 MPH = 65 FT) CENTER TO CENTER.
 - TANGENT - CHANNELIZING DEVICES SHALL BE SPACED 'S' (THE SPEED LIMIT IN FEET, 65 MPH = 65 FT) TO A MAXIMUM OF '2S' CENTER TO CENTER.
- "LOW SHOULDER" OR "UNEVEN LANES" SIGNS, WHEN USED, SHALL BEGIN PRIOR TO THE DROP-OFF CONDITION AND SHOULD BE REPEATED EVERY 1500 FEET.

**CHART B
40 MPH OR LESS
WITH CURB**

X (FEET)	DROP (D) (INCHES)	DEVICE REQUIRED
0-10'	LESS THAN OR EQUAL TO 12"	NONE
0-10'	GREATER THAN 12"	CHANNELIZING DEVICE
GREATER THAN 10	ANY	NONE

- NOTES:**
- USE THIS CHART ONLY FOR CONDITION 3.
 - USE THIS CHART FOR VERTICAL CURBS OF 6' OR GREATER FOR LOWER CURBS OR MOUNTABLE USE CHART A.
 - FOR CURBED SECTIONS WITH POSTED SPEEDS ABOVE 40 MPH USE CHART A.

OTHER STDS. E-101 E-107
REQUIRED: E-106 E-107A

REVISIONS AND CORRECTIONS

SEPT. 20, 1993 - DATE OF ORIGINAL ISSUE
AUG. 18, 1995 - ADDED SHOULDER WARNING NOTE

APPROVED FOR THIS PROJECT
AND/OR DESIGN IMPLEMENTATION.
FHWA FINAL APPROVAL PENDING.

APPROVED

Sandra M. Catlin
DIRECTOR OF ENGINEERING

David A. Ross
TRAFFIC AND SAFETY ENGINEER

CONSTRUCTION ZONE
LONGITUDINAL DROP OFFS

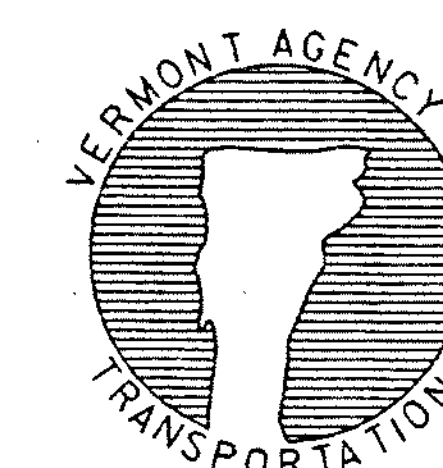

STANDARD
E-108