

SECTION 21

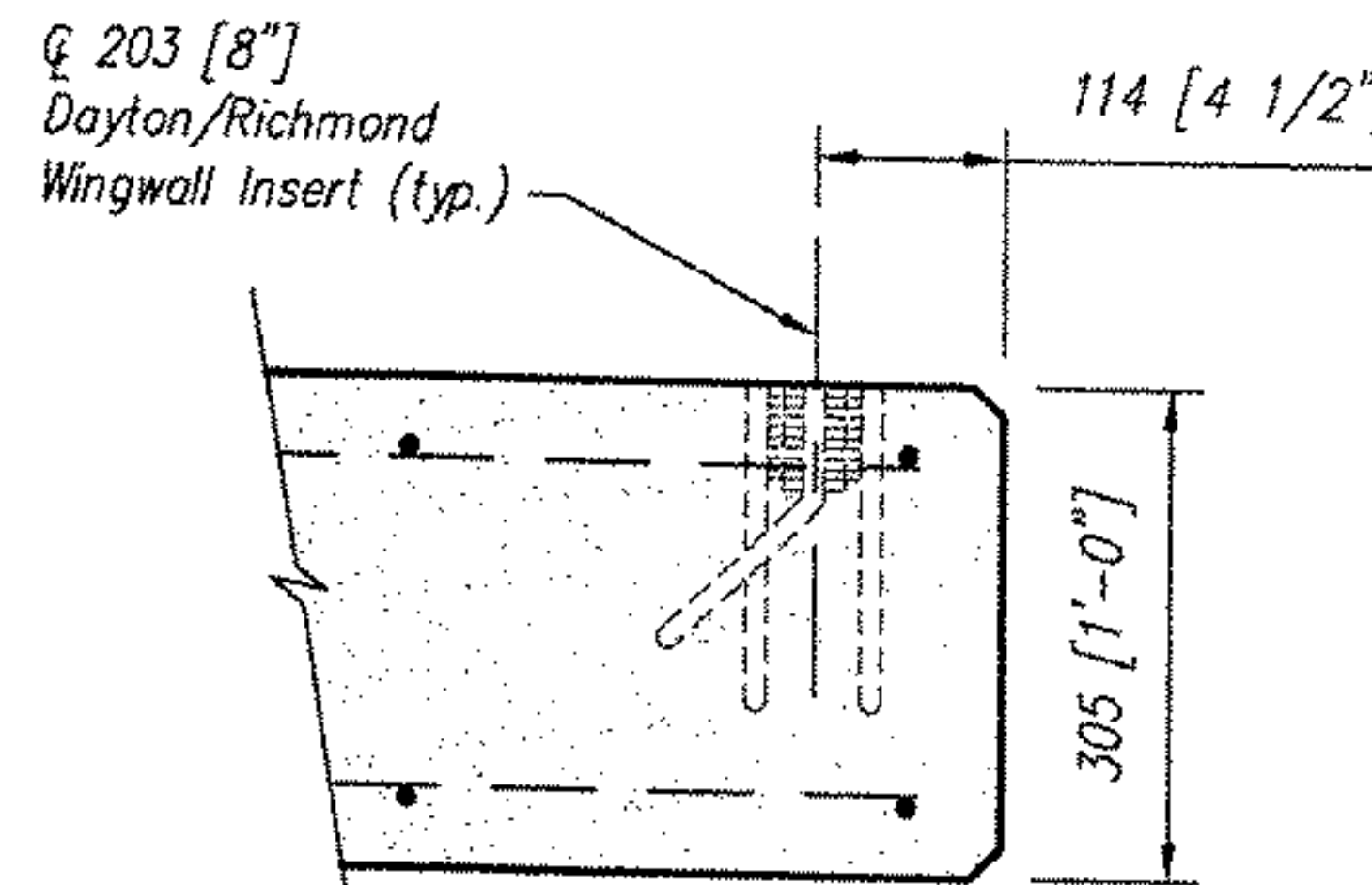

SECTION 22

Horizontal Bars:
16M [#5] @ 305 [1'-0"] o.c. max. each face (typ.)

Vertical Bars:
16M [#5] @ 305 [1'-0"] o.c. max. front side
19M [#6] @ 229 [9"] max. anchor side

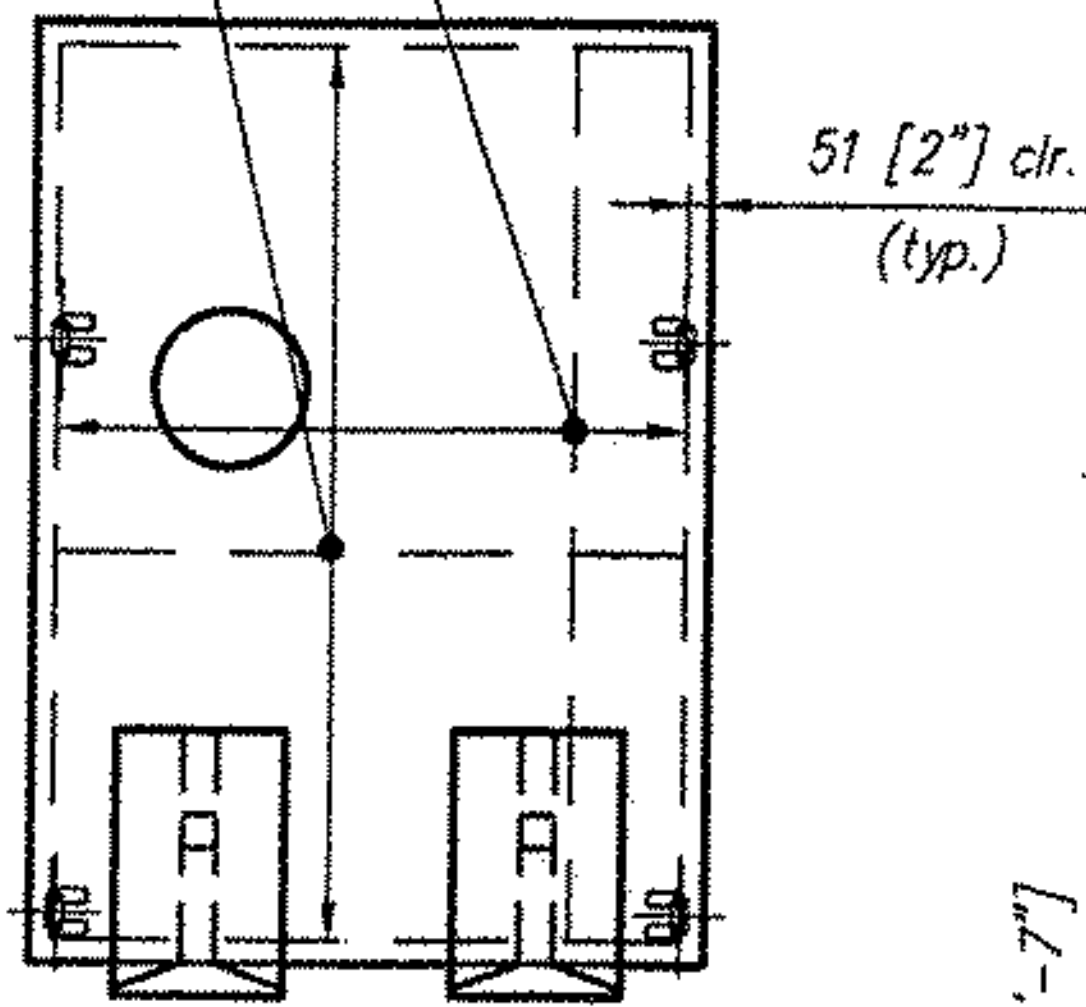

REINFORCING DETAIL
(See Section - Sheet S27)

Wingwall	
Concrete	Reinf. Steel
28-day: 34.5 MPa [5000 psi]	413.5 MPa [60,000 psi] epoxy coated

Wherever the reinforcing is cut for the placement of lift holes or other blockouts, reinforcing bars or wires of equivalent cross-sectional area shall be placed symmetrically around the hole. At least one bar must be on each side of the hole, and the development length of the bar must be achieved on either side of the cut.

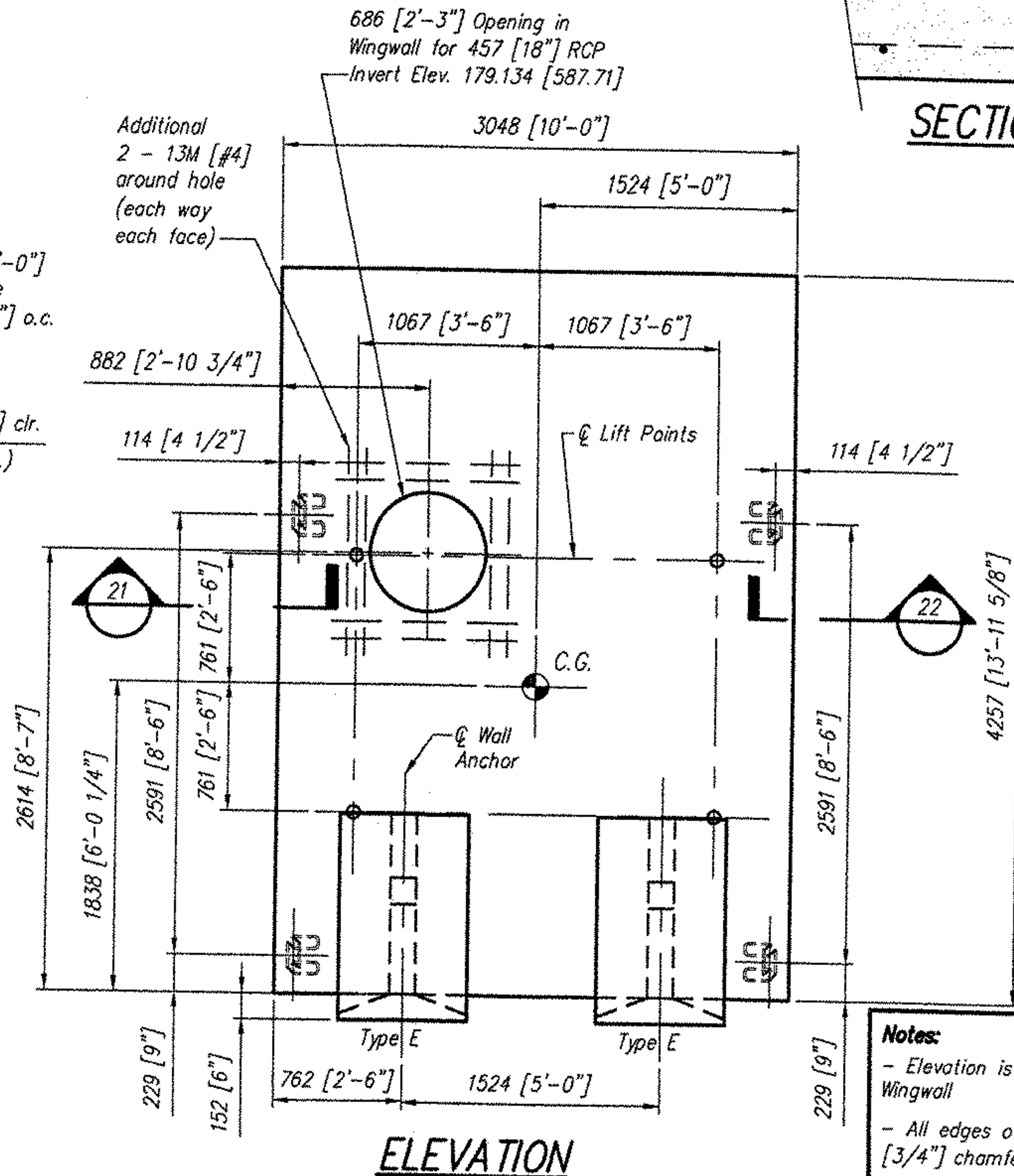

ELEVATION

Notes:
- Elevation is looking at back face of Wingwall
- All edges of Precast to have a 19 [3/4] inch chamfer

Total Weight = 11.6 Metric Tons [12.8 Tons]



Offices:
Dayton, OH (937) 254-2233
fax (937) 254-8365
Charlotte NC (704) 548-8420
Sacramento, CA (916) 787-8701
Albany, NY (518) 371-2871

CONSPAN® is a patented system and the furnishing of this drawing does not constitute an express or implied license.

Revisions:	
No.	Date
1	
2	
3	
4	

Sheet Title:
WINGWALL WW4b
SHOP DRAWING

Producer:
CONCRETE SYSTEMS, INC.
NEW ENGLAND
800-342-3374

VERMONT
ROCKINGHAM
VT. RTE. 121
BRIDGE NO. 7

Des. By: KJG	Job No. 11415
Drawn By: JLL	Sheet No. S25
Chk'd By: JVP	
Date: 6/22/04	081