

- GENERAL NOTES**
1. THE TERM "VEHICLE DETECTOR LOOP" SHALL REFER TO THE SENSOR EQUIPMENT EMBEDDED IN THE PAVEMENT WHICH SENSES VEHICLE PASSAGE OR PRESENCE. THE TERM "CABINET AMPLIFIER" SHALL REFER TO THE ELECTRICAL OR ELECTRONIC DEVICE LOCATED IN THE CONTROLLER CABINET WHICH RESPONDS DIRECTLY TO A VEHICLE ACTUATION AND INTERFACES WITH THE CONTROLLER.
  2. WHEN THE DISTANCE FROM THE SAWCUT TO THE CONTROLLER EXCEEDS 25 FEET, SHIELDED CABLE SHALL BE USED TO EXTEND LOOP LEAD-INS FROM A JUNCTION BOX, PULLBOX OR POLE BASE TO THE CABINET. IT SHALL MEET THE REQUIREMENTS OF ISMA SPEC. NO. 50-2.
  3. VEHICLE DETECTOR LOOP SHALL BE INSTALLED IN SUCH A WAY AS TO MAXIMIZE SENSITIVITY AND BE CAPABLE OF DETECTING MOTORCYCLES AND BICYCLES, WHILE ELIMINATING FALSE CALLS FROM VEHICLES IN ADJACENT LANES. LOOPS SHOULD BE DESIGNED SO THAT THE TOTAL INDUCTANCE ( LOOPS) PLUS LEAD-INS ) AT THE AMPLIFIER IS BETWEEN 100 AND 450 MICROHENRIES ( 200-300 PREFERRED ). FOR SINGLE LOOPS, THE LOOP INDUCTANCE SHOULD BE AT LEAST TWICE THAT OF THE LEAD-IN. FOR MULTIPLE LOOPS, THE INDUCTANCE ON THE STREET SIDE OF THE SPLICE SHOULD BE AT LEAST TWICE THAT ON THE CONTROLLER SIDE.
  4. THE LOOPS SHALL BE CENTERED IN THEIR RESPECTIVE LANES, UNLESS OTHERWISE NOTED.
  5. ALL LOOPS SHALL OPERATE IN THE PRESENCE MODE WITH THE CONTROLLER SET TO LOCKING MEMORY FOR "LEFT-ONLY" OR "THRU-ONLY" LANES. ALL OTHER LANES SHALL UTILIZE NON-LOCKING MEMORY, UNLESS OTHERWISE NOTED.
  6. ALL LOOPS IN "RIGHT TURN ONLY" LANES OR LOOP PLACED TO DETECT ONLY RIGHT TURNING VEHICLES SHALL HAVE DELAYED CALL LOOP AMPLIFIERS, UNLESS OTHERWISE NOTED.
  7. ALL LOOP DETECTORS SHALL BE OF A TYPE THAT FAIL IN THE "ON" MODE.
  8. ALL LOOP AND LEAD-IN WIRE SHALL BE #12 AWG. THE RESISTANCE OF #12 AWG IS 1.62 OHMS / 1000' AT 77° F.
2. ALL LOOP WIRES SHALL BE INSTALLED IN PVC TUBING. THE TUBING ENDS SHALL BE SEALED USING LOOP SEALANT PRIOR TO INSTALLATION IN THE SAWCUT.
  3. BEFORE LAYING IN THE LOOP WIRE, A ONE-QUARTER INCH BEAD OF SEALANT SHALL BE PLACED IN THE SAWCUT AND ALLOWED TO SET UP SUFFICIENTLY TO GIVE THE WIRE SOME SUPPORT. EACH WIRE SHALL BE EASED INTO THE SAWCUT WITH A BLUNT WOODEN STICK.
  4. THE LOOP WIRES SHALL BE HELD IN PLACE DURING INSTALLATION BY SHORT STRIPS OF POLYETHYLENE FOAM SEALANT BACKERS. THE STRIPS SHALL BE ABOUT 2" LONG AND PLACED EVERY 2 FEET. THEY ARE TO REMAIN IN PLACE WHEN THE SLOT IS SEALED.
  5. VEHICLE-DETECTOR LOOPS SHALL BE PLACED IN SAWCUTS IN THE PAVEMENT COURSE IMMEDIATELY BELOW THE WEARING SURFACE AND PAVED OVER WHENEVER POSSIBLE. IF THE WEARING SURFACE IS MORE THAN 1-3/4" IN DEPTH, THE SAWCUT SHALL BE MADE AFTER THE WEARING SURFACE IS PLACED. IF PAVING IS NOT PART OF THE PROJECT, THE SAWCUT SHALL BE MADE IN EXISTING PAVEMENT.
  6. WHEN LOOP WIRES ARE PLACED BELOW THE WEARING SURFACE, THE SEALANT SHALL BE PROPERLY CURED BEFORE THE FINAL PAVEMENT IS PLACED.
  7. LOOP LEAD-INS FROM ADJACENT LOOPS ACTUATING DIFFERENT PHASES SHALL BE IN SEPARATE SAWCUTS AND CONDUITS TO THE PULLBOX OR POLE BASE.
  8. LOOP LEAD-INS SHALL BE KEPT AT LEAST ONE FOOT AWAY FROM POWER WIRING, WHENEVER POSSIBLE.
  9. ALL ELECTRICAL WORK AND MATERIALS SHALL MEET THE REQUIREMENTS OF THE NATIONAL ELECTRIC CODE.
  10. LOOP WIRES FROM EACH LOOP AND/OR APPROACH SHALL BE COLOR CODED OR OTHERWISE IDENTIFIED AT EACH PULLBOX OR JUNCTION BOX, IN THE POLE BASE(S) AND AT THE TERMINAL BOARD IN THE CONTROLLER CABINET. FOLLOWING INSTALLATION, THE CONTRACTOR SHALL SUPPLY 2 COPIES OF A SCHEMATIC SHOWING THE FOLLOWING INFORMATION.
    1. NUMBER OF TURNS.
    2. DIMENSIONS FOR EACH LOOP.
    3. LOOP LEAD-IN ROUTING FROM THE SAWCUT TO THE CONTROLLER.
    4. TYPE OF CONNECTIONS AT EACH SPLICE (SERIES, PARALLEL OR SERIES-PARALLEL).
 ONE COPY SHALL BE LEFT IN THE CONTROLLER CABINET AND THE OTHER GIVEN TO THE TRAFFIC SHOP OR LOCAL OFFICIAL RESPONSIBLE FOR THE SIGNAL MAINTENANCE.

**LONG LOOPS**

**LOOP INDUCTANCE DESIGN TABLE**

LOOP INDUCTANCE (MICROHENRIES)

LENGTH OF LOOP (FEET)	WIDTH OF LOOP					
	6 FEET			8 FEET		
	1 TURN	2 TURNS	3 TURNS	1 TURN	2 TURNS	3 TURNS
10	-	98	206	-	104	218
15	-	138	291	-	144	303
20	-	178	376	-	184	388
25	-	218	461	-	224	473
30	-	258	546	-	264	558
35	-	298	-	-	304	-
40	106	338	-	108	344	-
45	146	378	-	148	384	-
50	186	418	-	188	424	-
55	226	458	-	228	464	-
60	266	498	-	268	504	-
65	306	538	-	310	544	-
70	346	578	-	350	584	-

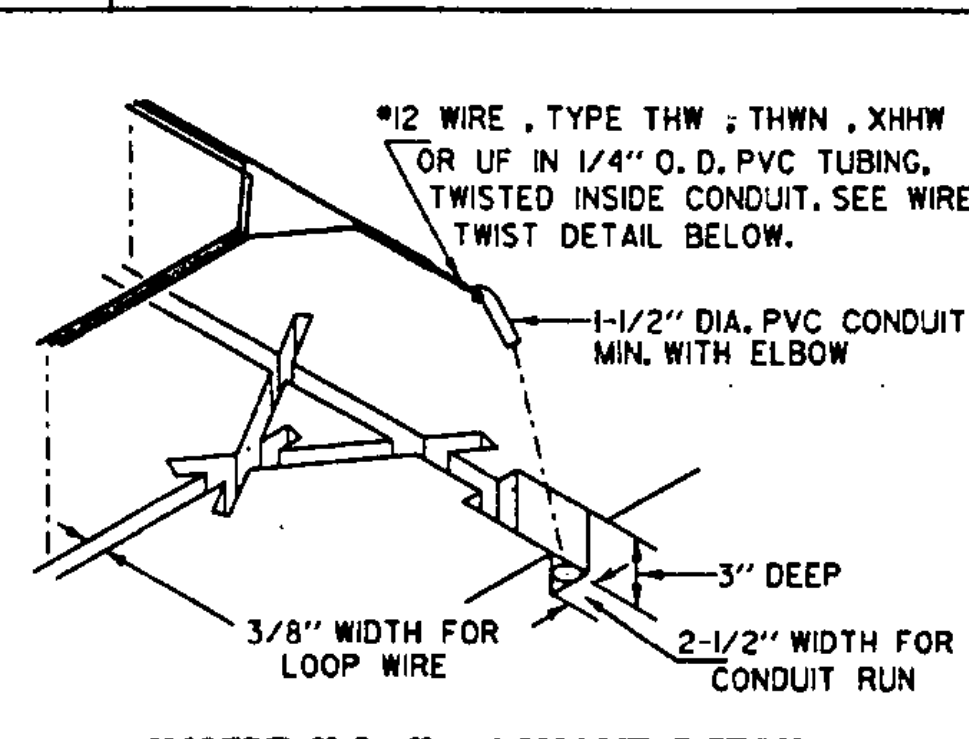

**RECTANGULAR LOOPS**

**LOOP INDUCTANCE DESIGN TABLE**

LENGTH OF LOOP (FEET)	WIDTH OF LOOP				LOOP PERIMETER (FT.)	LOOP INDUCTANCE (MICROHENRIES)			
						2 TURNS	3 TURNS	4 TURNS	5 TURNS
	4 FEET	6 FEET	8 FEET	10 FEET		K=42	K=36	K=33	K=33
8	6	-	-	24	40	82	138	198	
10	8	-	-	28	47	96	161	231	
12	10	-	-	32	54	109	184	264	
14	12	-	-	36	60	123	207	297	
16	14	-	-	40	67	137	230	330	
18	16	-	-	44	74	151	254	363	
20	18	-	-	48	81	164	277	396	
22	20	-	-	52	87	178	300	429	
24	22	-	-	56	94	192	323	462	
26	24	-	-	60	101	205	346	495	
28	26	-	-	64	108	219	369	-	
30	28	-	-	68	114	232	392	-	
32	30	-	-	72	121	246	415	-	
34	32	-	-	76	128	260	438	-	
36	34	-	-	80	135	274	461	-	
38	36	-	-	84	142	288	484	-	
40	38	-	-	88	149	302	507	-	

**NOTE:**

1. THE ABOVE INDUCTANCES ARE ESTIMATED VALUES USING THE FOLLOWING EQUATIONS.
  - 1 TURN = (PERIMETER X 0.5) + (LOOP LENGTH X 1.5)
  - 2 TURN = (PERIMETER X 1.5) + (LOOP LENGTH X 5.0)
  - 3 TURN = (PERIMETER X 3.0) + (LOOP LENGTH X 11.0)
2. SEE NOTES # 1 & 3 UNDER THE RECTANGULAR LOOP TABLE.

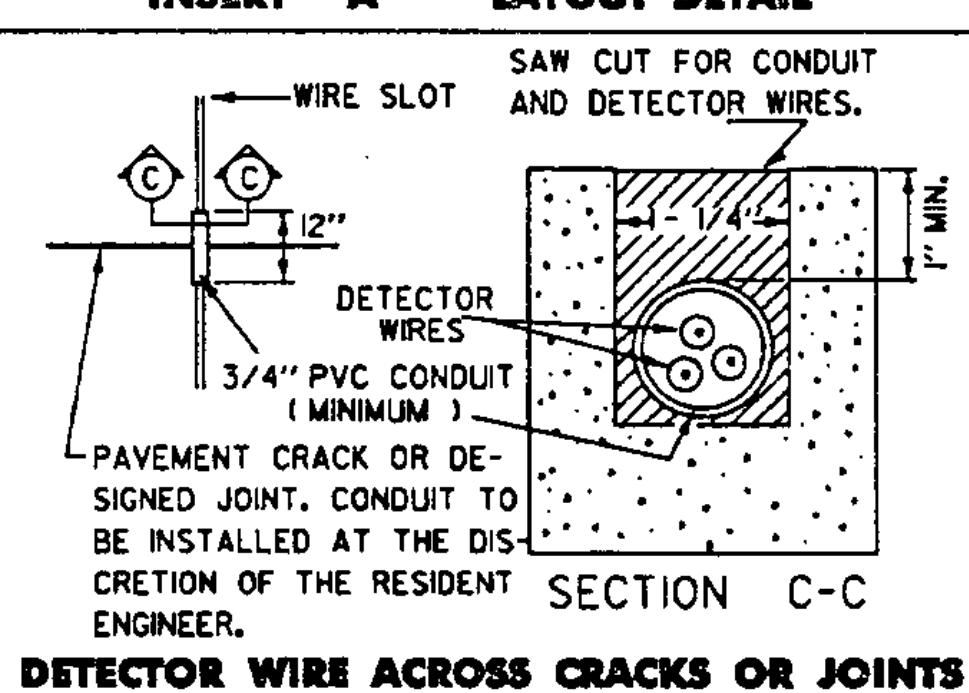

**NOTE:**

1. TO THE ABOVE LOOP INDUCTANCES, ADD 25 MICROHENRIES FOR EACH 100 FEET OF LEAD-IN CABLE FROM THE PAVEMENT LOOP TO THE CONTROLLER CABINET. LOOP LEAD-IN LENGTH SHALL NOT EXCEED 750 FEET.
2. THE FORMULA USED FOR THE TABLE ABOVE IS INDUCTANCE (L) = KPN<sup>2</sup> WHERE K =  $\frac{5}{10+N}$ , N = NO. OF TURNS, P = LOOP PERIMETER.
3. WHEN LOOPS ARE CONNECTED IN SERIES (PREFERRED FOR SMALL LOOPS), THE TOTAL INDUCTANCE BECOMES THE SUM OF ALL INDUCTANCES. WHEN LOOPS ARE CONNECTED IN PARALLEL (PREFERRED FOR LONG LOOPS), THE COMBINED INDUCTANCE CAN BE CALCULATED FROM THE FOLLOWING EQUATION.
 
$$L_p = \left[ \frac{1}{L_1} + \frac{1}{L_2} + \frac{1}{L_3} \right] + \text{LOOP LEAD-IN INDUCTANCES.}$$

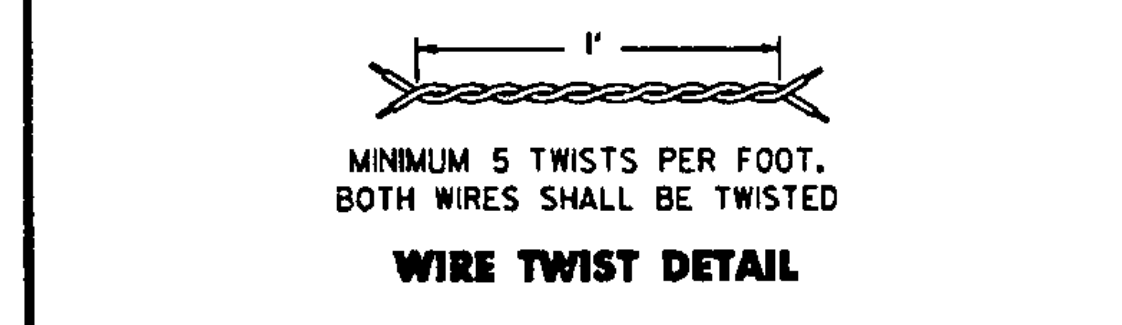

**INSTALLATION NOTES**

1. ALL SPLICES SHALL BE MADE IN PULLBOXES, JUNCTION BOXES, OR POLE BASES. ALL SPLICES SHALL BE SOLDERED, USING ROSIN CORE SOLDER, AND THEN BE FULLY SEALED BY THE APPLICATION OF DUAL-WALL, HEAT-SHRINKABLE TUBING, UNLESS OTHERWISE NOTED. A MINIMUM OF 3' OF SLACK SHALL BE LEFT IN EACH CABLE IN EACH BOX OR BASE.

**LOOP TESTING**

DURING INSTALLATION OF THE LOOPS, THE CONTRACTOR SHALL MEASURE THE LOOP INDUCTANCE, LEAKAGE TO GROUND AND LOOP RESISTANCE IN THE PRESENCE OF THE RESIDENT ENGINEER. THE CONTRACTOR SHALL PROVIDE THE APPROPRIATE EQUIPMENT. THE INSTALLATION SHALL BE CONSIDERED ACCEPTABLE IF:

1. THE INDUCTANCE READING IS WITHIN 10% ± OF THE CALCULATED VALUE.
2. THE INSULATION TEST (LEAKAGE TO GROUND) IS ABOVE 5 MEGOHMS FOR EXISTING LOOPS AND 100 MEGOHMS FOR NEW LOOPS USING A 500 VOLT DC INPUT.
3. THE LOOP RESISTANCE IS WITHIN 25% ± OF THE CALCULATED VALUE.

IF THE READINGS FALL OUTSIDE THE ABOVE RANGES, CORRECTIVE MEASURES MAY BE REQUIRED AND THE ENGINEER SHALL NOTIFY THE TRAFFIC AND SAFETY DIVISION. THE COST OF TESTING THE LOOPS AND ANY NECESSARY CORRECTIONS SHALL BE SUBSIDIARY TO THE ITEM "VEHICLE DETECTOR LOOP". THE CALCULATED VALUES SHALL BE SHOWN ON THE PLANS. LOOP TESTING IS NOT REQUIRED FOR TEMPORARY LOOPS.

**CONDUIT FILL DESIGN VALUES**

AVAILABLE CONDUIT AREA			CONDUCTOR SIZE TABLE						
SIZE	I.D.	SIZE O.D.	26% FILL (IN 2)	Gauge					
1"	1.315	1.315	0.23						
1-1/4"	1.660	1.660	0.39						
1-1/2"	1.900	1.900	0.53						
2"	2.375	2.375	0.87						
2-1/2"	2.875	2.875	1.24						
3"	3.500	3.500	1.92						
3-1/2"	4.000	4.000	2.57						
4"	4.500	4.500	3.31						

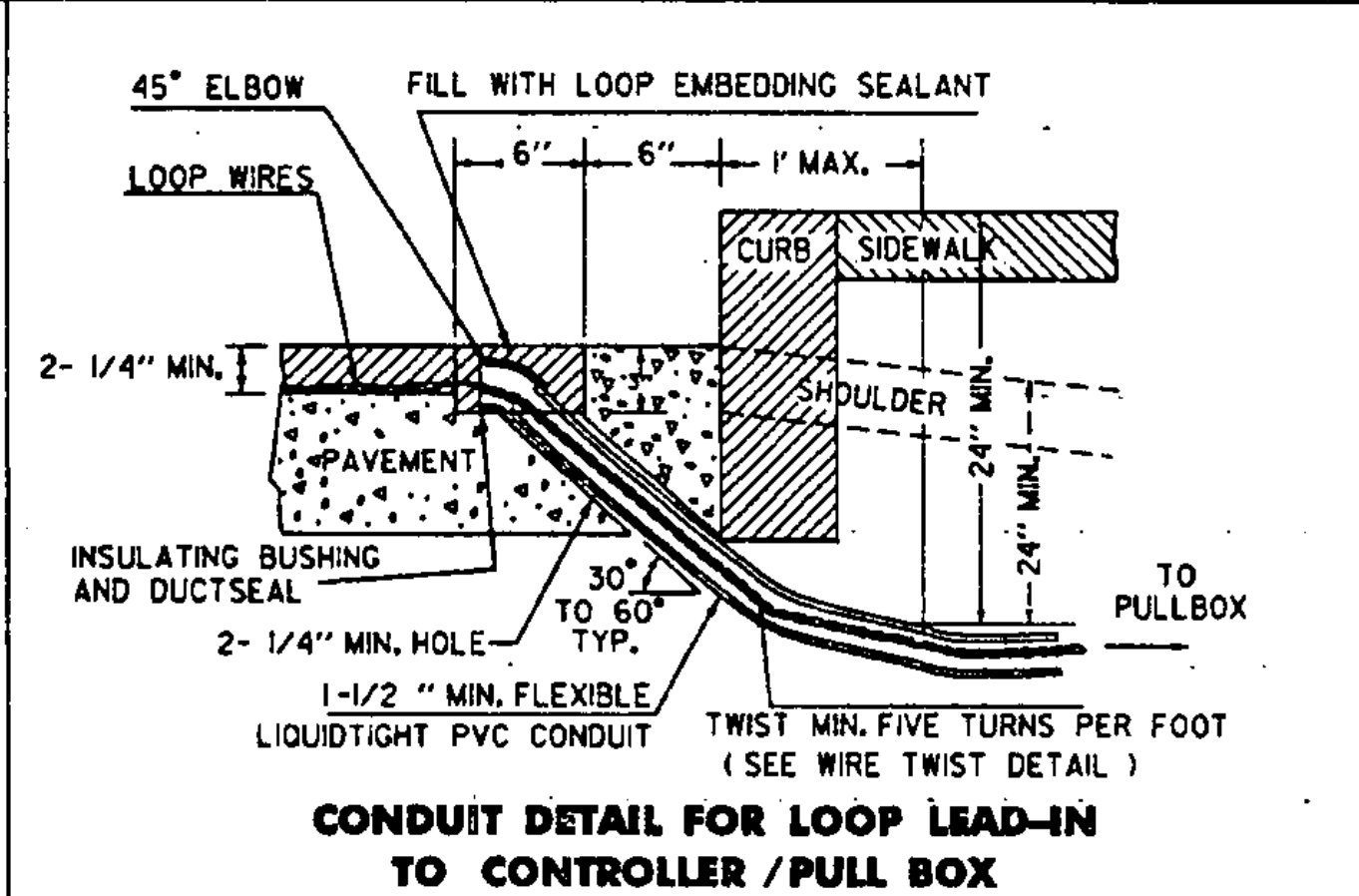
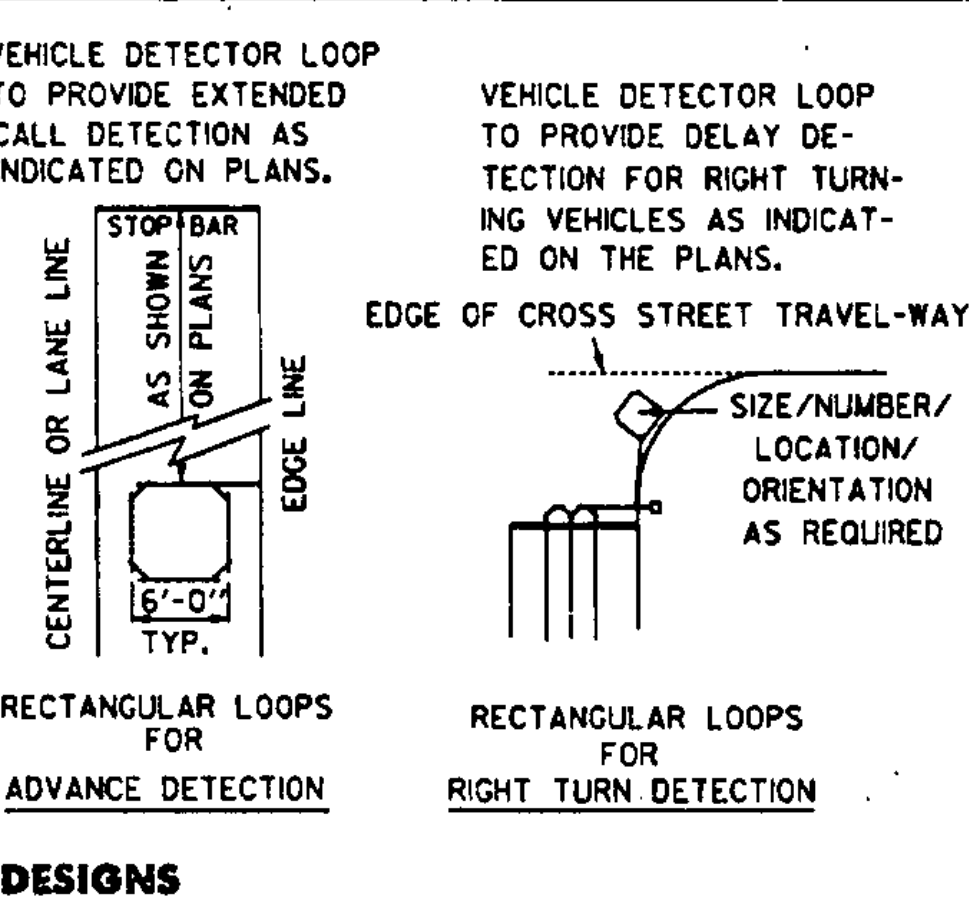
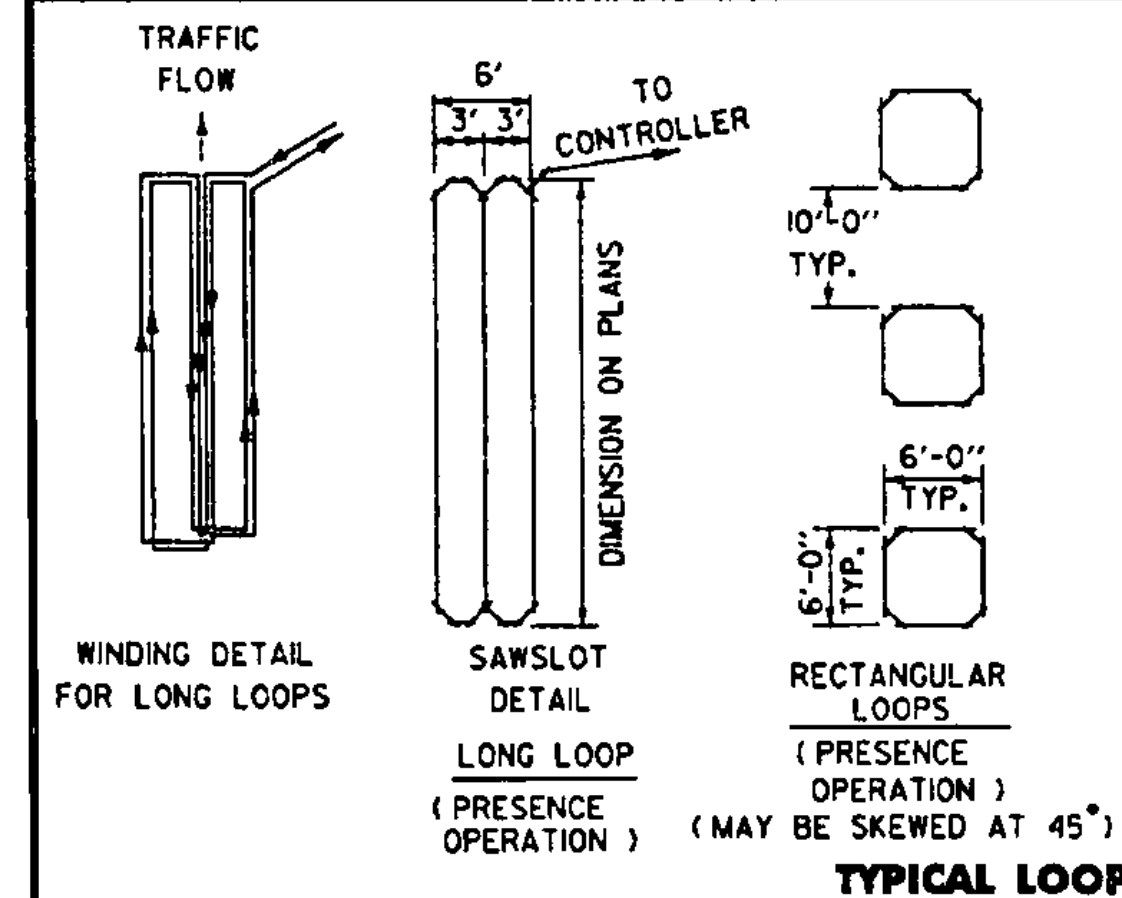

**REVISIONS AND CORRECTIONS**

SEPT. 10, 1987 - DATE OF ORIGINAL ISSUE  
 NOV. 17 1993 - MAJOR NOTE & TABLE REVISIONS  
 AUG. 9, 1995 - REVISED INSTALLATION NOTES 5 & 6, TYP. LOOP DESIGN & MINOR CHANGES

APPROVED FOR THIS PROJECT AND/OR DESIGN IMPLEMENTATION, FHWA FINAL APPROVAL PENDING.

**APPROVED**

*Stephen D. McArthur*  
 DIRECTOR OF ENGINEERING

*David A. Ross*  
 TRAFFIC AND SAFETY ENGINEER

**VEHICLE DETECTOR LOOP DETAILS**

/traf/std/stdel72.dgn - stdel72.j

**OTHER STDS. REQUIRED** NONE

**VERMONT AGENCY OF TRANSPORTATION**

**STANDARD E-172**