

POST SIZE (LB./FT.)	DIMENSIONS			SECTION MODULUS, X-X
	A	B	C	
2	1 3/8"	1 3/4"	3 1/8"	0.225 IN. ³
3	1 5/8"	1 7/8"	3 1/2"	0.403 IN. ³

SIMILAR DIMENSIONS ARE ACCEPTABLE, HOWEVER SECTION MODULUS VALUES SHALL NOT BE EXCEEDED.

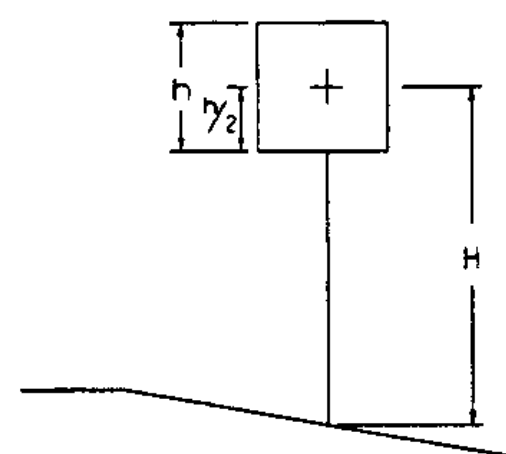

POST SELECTION CHART		
SIGN AREA (FT ²) x H (FT) / SV (SELECTION VALUE)		
POST SIZE	SV	DESIGN CRITERIA
2 LB./FT. (ONE POST INSTALLATION)	32	WIND SPEED = 60 MPH (10-YEAR MEAN RECURRENCE INTERVAL)
2 LB./FT. (TWO POST INSTALLATION)	62	WIND PRESSURE = 13 PSF
3 LB./FT.	107	STEEL MIN. YIELD F _y = 50,000 PSI ALLOWABLE STRESS = (1.4) 10.60 F _y

SINGULAR 2 LB./FT. POSTS SHALL ONLY TO BE USED IN URBAN AREAS.

MULTI-POST INSTALLATIONS

WHEN SIGN POSTS ARE INSTALLED WITH A POST SPACING OF LESS THAN 8 FEET, POST SIZES MUST BE SELECTED TO INSURE THAT WHEN ACTING TOGETHER THE POSTS DO NOT CREATE A HAZARD. REFER TO V.A.O.T. SIGN POST DESIGN GUIDELINE FOR ADDITIONAL DETAILS.

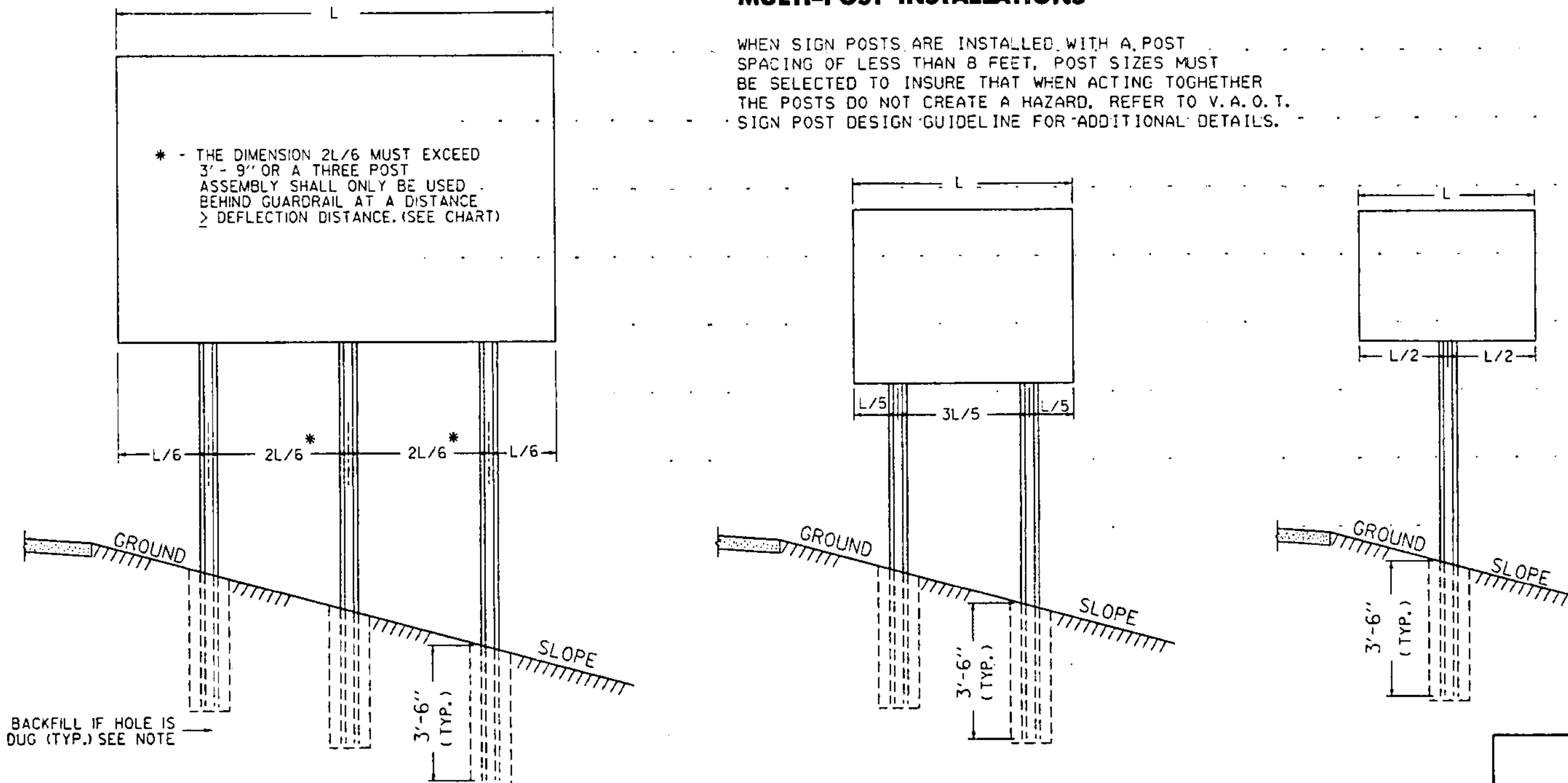

GENERAL NOTES

CONSTRUCTION METHODS - POSTS MAY BE DRIVEN OR SET IN A DUG HOLE AND BACKFILLED. IF DRIVEN, A DRIVING CAP SHALL BE USED. THE DUG HOLE INSTALLATION SHALL BE USED IN AREAS OF POOR SOIL CONDITIONS OR AS DIRECTED BY THE RESIDENT ENGINEER. BACKFILL SHALL BE COMPACTED AS DIRECTED BY THE RESIDENT ENGINEER.

IN AREAS WHERE LEDGE ROCK IS ENCOUNTERED, POSTS WILL BE SET IN A HOLE WITH 2' CLEARANCE AND GROUTED WITH TYPE 4 MORTAR 24" BELOW THE SURFACE OF THE SOLID ROCK, UNLESS THE POSTS PENETRATE THE GROUND A MINIMUM OF 3'-6". THE PORTION OF THE POST IN CONTACT WITH THE MORTAR SHALL BE COATED WITH AN APPROVED COATING.

SIGN CLEARANCES - HORIZONTAL AND VERTICAL SIGN CLEARANCES SHALL BE SHOWN ON THE PLANS OR THE APPROPRIATE STD. SHEETS.

SINGLE POST INSTALLATIONS SHALL BE LIMITED TO A SIGN AREA OF 12-1/2 SQ. FT. OR LESS.

POST SPACING DETAILS

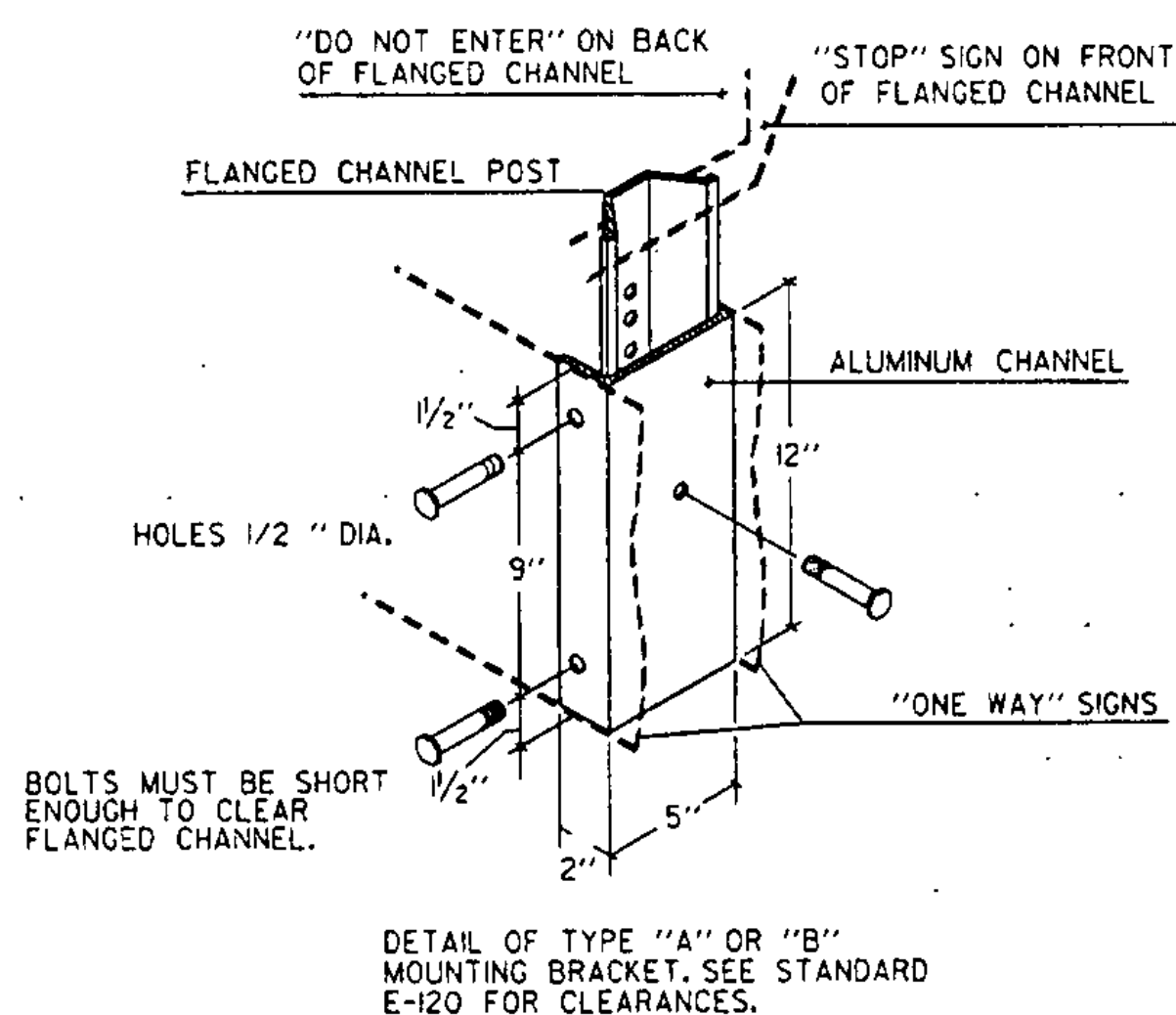

GUARDRAIL DEFLECTION CHART (PER AASHTO - ROADSIDE DESIGN GUIDE - 1988)		
TYPE	GR POST SPACING	DEFLECTION
THREE CABLE W/STEEL POSTS	16' - 0"	12'
W/WOODEN POSTS	12' - 6"	12'
W-BEAM W/WEAK POST	12' - 6"	7'
W/STRONG POST	6' - 3"	3'
BOX BEAM	6' - 0"	5'
THRIE BEAM . W/WEAK POST	12' - 6"	4' - 4"
W/STRONG POST	6' - 3"	2'

THIS CHART LISTS THE THEORETICAL DEFLECTION DISTANCE UPON IMPACT OF VARIOUS GUARDRAIL WITH DIFFERENT TYPES AND SPACING OF POSTS.

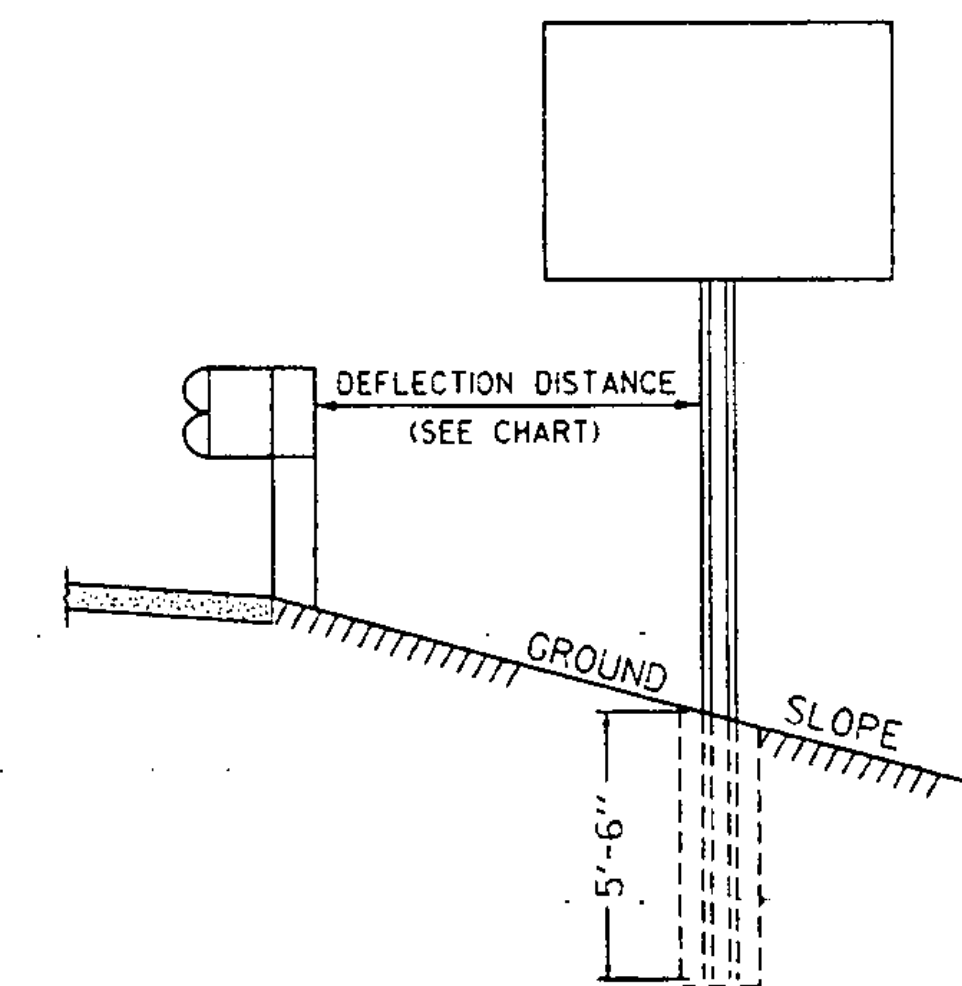

WHEN USING FLANGED CHANNEL POSTS ON STEEP SLOPES (1 ON 2 OR STEEPER FILL SLOPES BEHIND GUARDRAIL), ADD 2' EMBEDMENT TO THE POST LENGTH TO GIVE THE ASSEMBLY MORE STABILITY. HOWEVER IF SIGN POST IS LOCATED INSIDE THE DEFLECTION DISTANCE, THE SIGN POST SHALL BE SET AT A DEPTH OF 3' - 6".

OTHER STDS. REQUIRED:

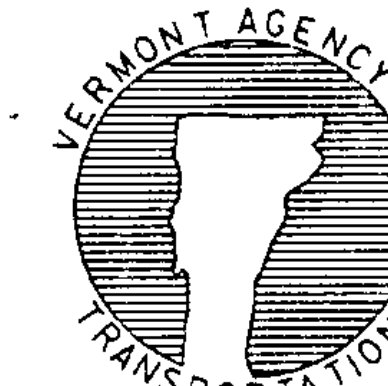

STANDARD E-160

REVISIONS AND CORRECTIONS

- SEP. 10, 1987 - DATE OF ORIGINAL ISSUE
- MAR. 01, 1988 - FHWA REVIEW COMMENTS
- OCT. 21, 1992 - ADDED DETAILS, REVISED NOTES & REVISED TITLE BLOCK
- AUG. 18, 1995 - DELETION OF 2.5 #/FT. POST AND TWO-RAIL ALUMINUM. ADDED ADDITIONAL NOTE.

APPROVED FOR THIS PROJECT AND/OR DESIGN IMPLEMENTATION. FHWA FINAL APPROVAL PENDING.

APPROVED

George J. MacArthur
DIRECTOR OF ENGINEERING

David A. Bas
TRAFFIC AND SAFETY ENGINEER

FLANGED CHANNEL STEEL SIGN POST

/traf/std/stdel60.dgn : stdel60.i