

GRATE SIZE SINGLE 24 3/4" X 30"
DOUBLE 24 3/4" X 54"

WEIGHT 95 LBS OR MORE
GRATES SHALL BE CAPABLE OF SUPPORTING H-20 (32,000 LB. AXLE LOAD) INCLUDING 30% IMPACT.

UNIT STRESSES (LBS PER SQ. IN.)	18,000	20,000
MAIN BAR PARALLEL TO TRAFFIC H-20	49"	53"
MAIN BAR PERPENDICULAR TO TRAFFIC H-20	39"	42"

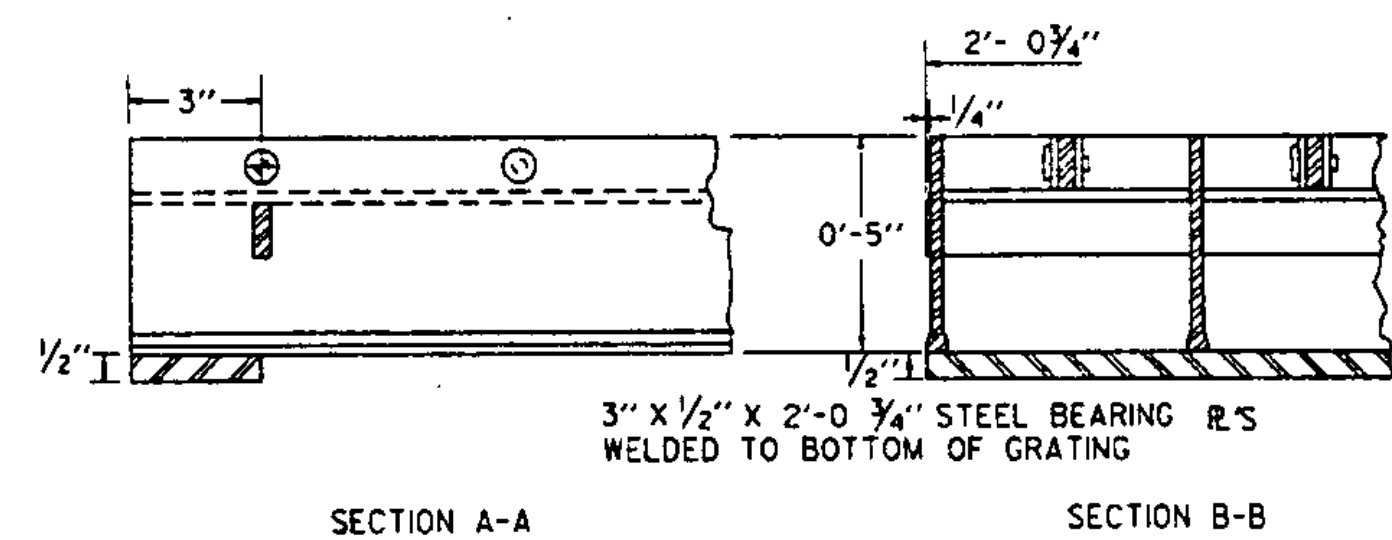

CAST IRON COVER WITH FRAME

BAR	NO.	LENGTH	
B	4	8"	3'-8" 8"
C	6	3'-8"	STRAIGHT
D	4	3'-8"	STRAIGHT

ALL REINFORCING STEEL TO BE NO. 5 DEFORMED BARS

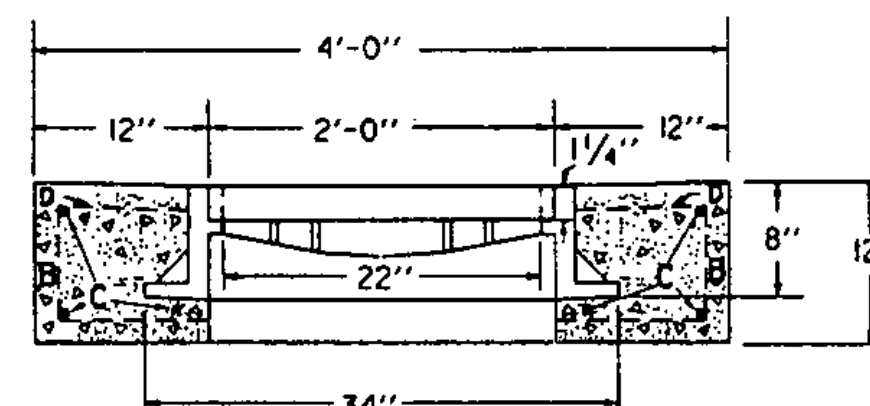

ELEVATION

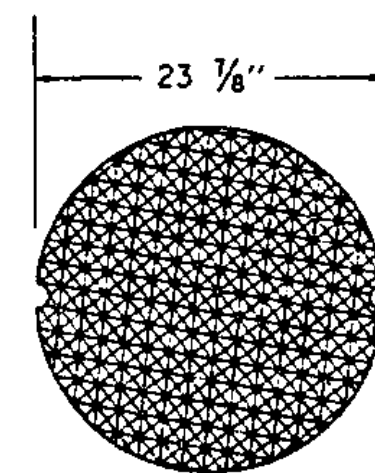

PLAN

GENERAL NOTES:
WEIGHT OF FRAME AND COVER = 425 LBS.

CAST IRON GRATE WITH FRAME

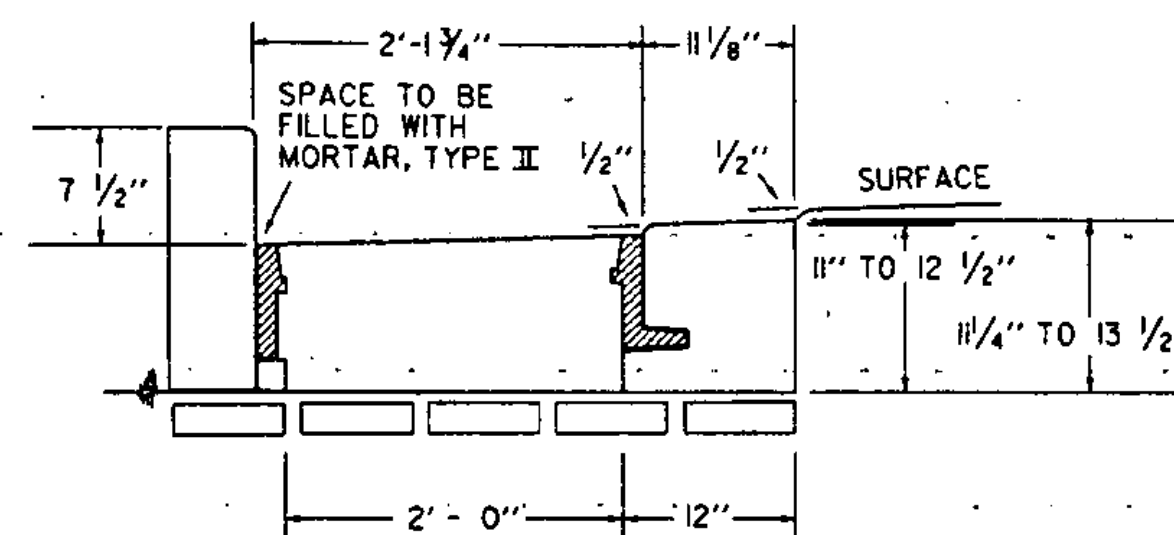

ELEVATION OF REINFORCED CONCRETE DROP INLET WITH VERTICAL GRANITE CURB AND 3 FLANGE CAST IRON FRAME FOR CAST IRON GRATE

SEE STANDARD D-9 FOR CONCRETE VOLUME, REINFORCING STEEL SCHEDULE, AND CURB JOINT DETAIL.

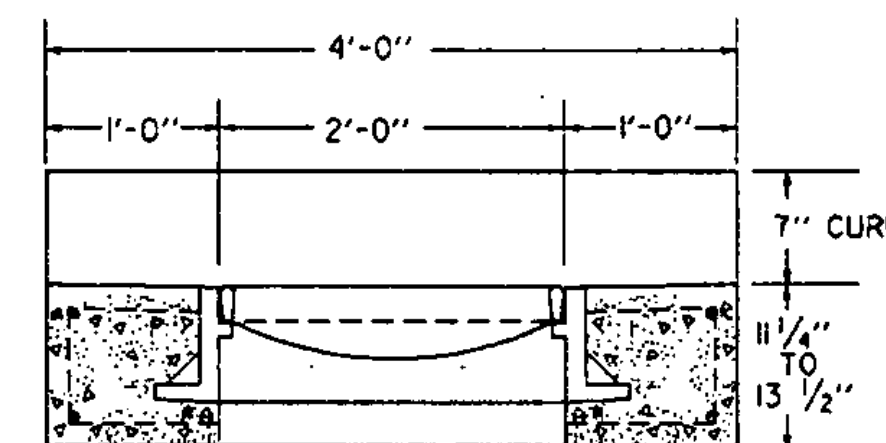

ELEVATION

WEIGHT OF 3 FLANGED FRAME AND GRATE

GRATE	220 LBS
FRAME	260 LBS
TOTAL	480 LBS

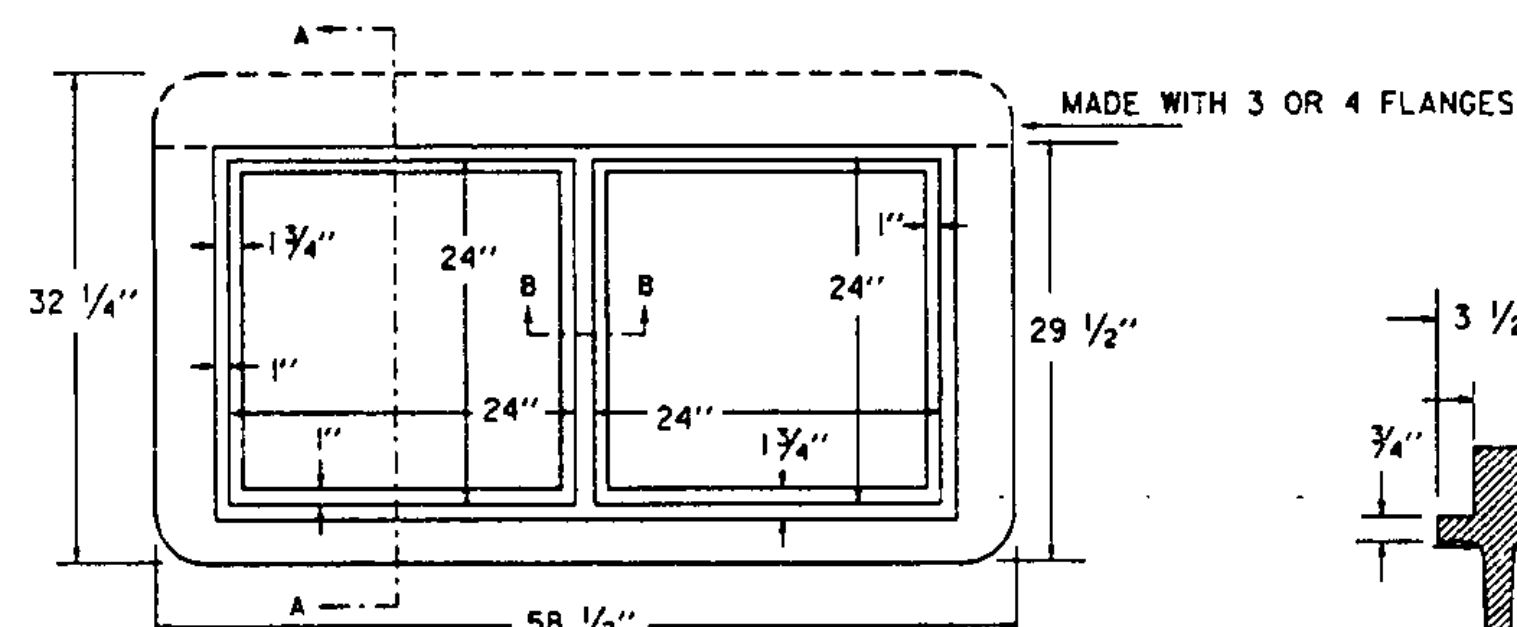

PLAN

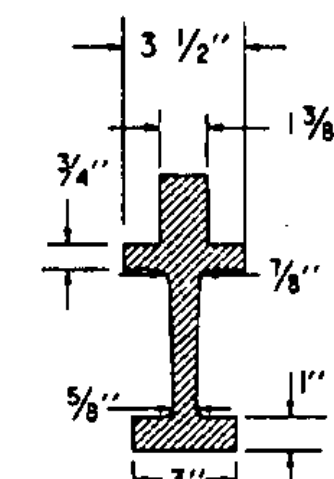

SECTION B-B

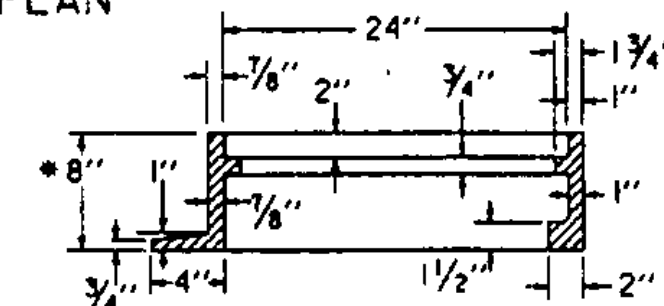

SECTION A-A

RECTANGULAR CAST IRON FRAME FOR TWO 24" SQUARE CAST IRON GRATES

CAST IRON GRATE, TYPE A

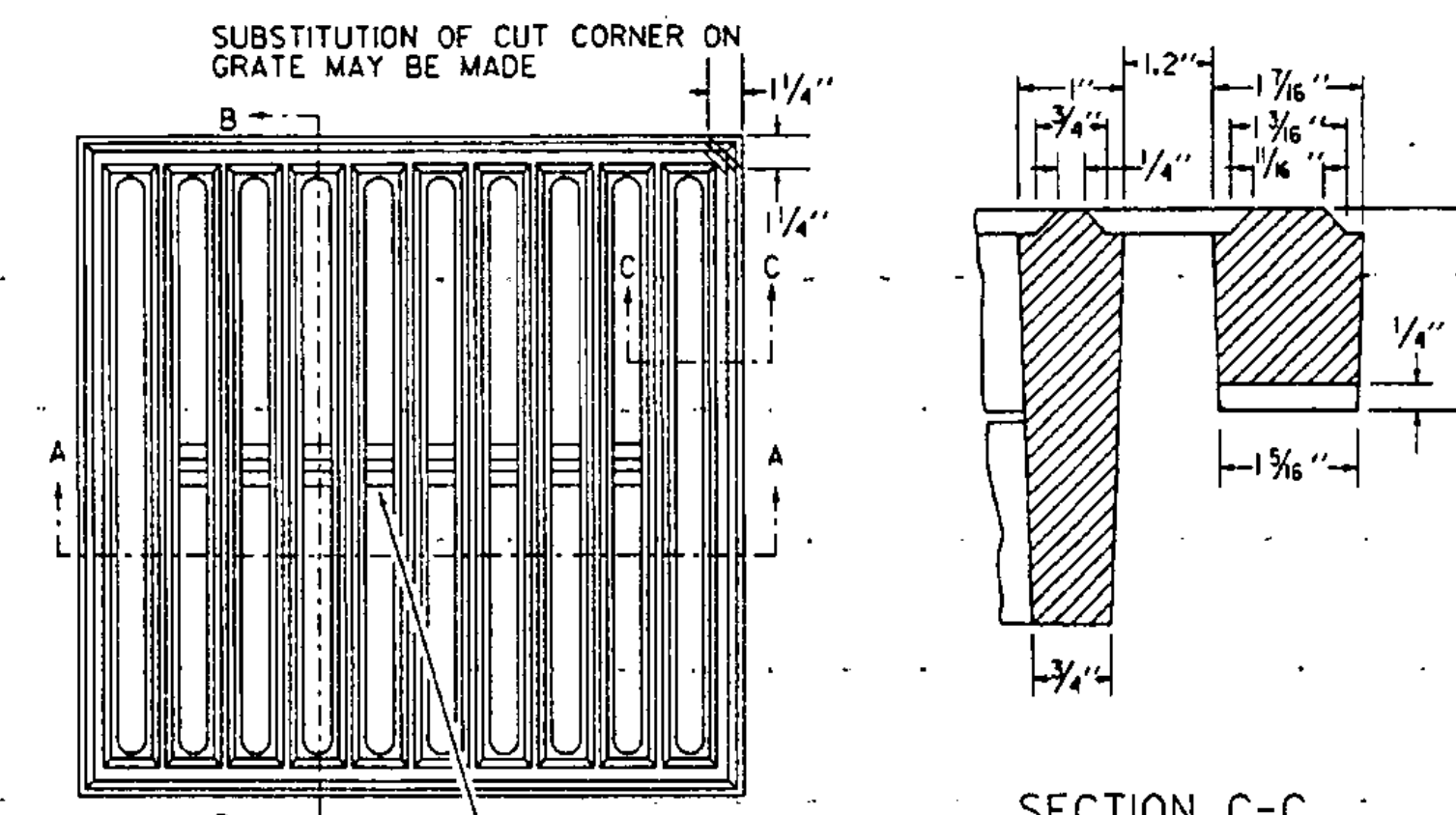

PLAN

SECTION C-C

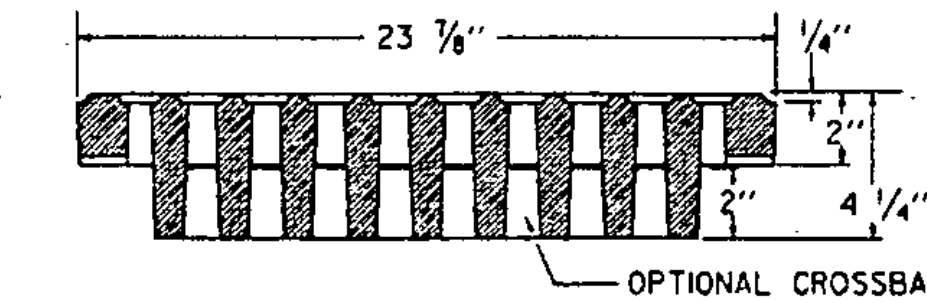

SECTION A-A

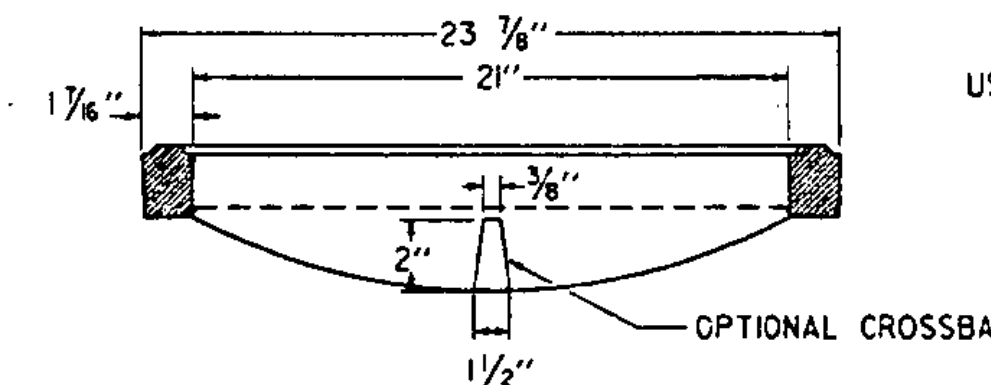

SECTION B-B

USE OF THE TYPE A GRATE IS PROHIBITED WHERE BICYCLE TRAFFIC IS EXPECTED

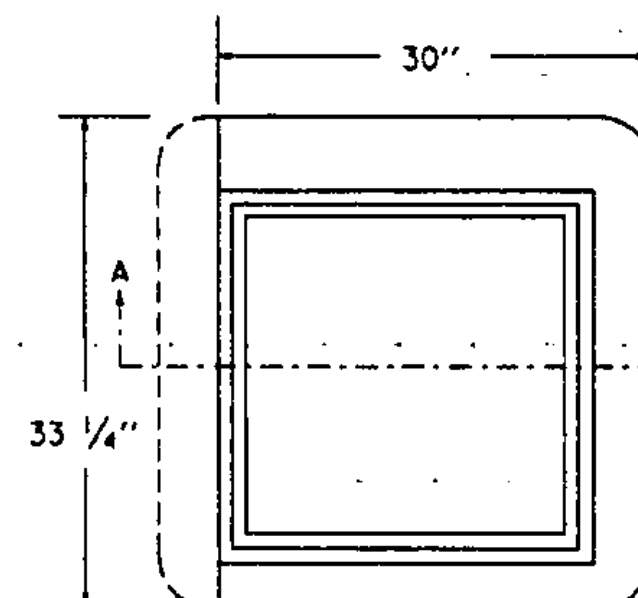

PLAN

SQUARE CAST IRON FRAME FOR CAST IRON GRATE TYPE A

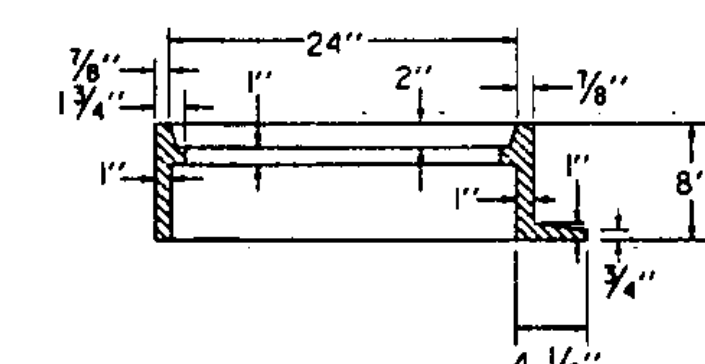

SECTION A-A

* NOTE: FRAME DEPTH TO BE "6" WHEN USED IN CONJUNCTION WITH DROP INLET DETAILED ON STANDARD D-6.

THIS FRAME TO BE PLACED IN DROP INLET TOP BEFORE CONCRETE IS POURED.

4 FLANGES UNLESS OTHERWISE INDICATED. FRAMES TO BE FURNISHED WITH 3 FLANGES WHEN USED IN CONJUNCTION WITH CURB OR AS DIRECTED BY THE ENGINEER.

REVISIONS AND CORRECTIONS
DEC. 6, 1971 - ORIGINAL APPROVAL
APR. 25, 1972 - CAST IRON COVER CHANGED FROM SQUARE TO CIRCULAR
SEPT. 4, 1980 - OPTIONAL CROSSBAR ADDED TO A GRATE; NOTE ADDED TO A GRATE FRAME DETAIL
AUG. 25, 1981 - NOTE ADDED RESTRICTING USE OF TYPE A GRATE
JUNE 1, 1994 - REISSUED, WITHOUT CHANGE, UNDER NEW SIGNATURES.

APPROVED

APPROVED FOR THIS PROJECT AND/OR DESIGN IMPLEMENTATION, FINA FINAL APPROVAL PENDING.

Robert M. Murphy, PE
DIRECTOR OF ENGINEERING
Albert M. Murphy, PE
DESIGN ENGINEER

STEEL GRATE
CAST IRON GRATE TYPE A
CAST IRON COVER



STANDARD
D-11