

MATERIALS
The sign materials shall be 0.063 aluminum with colors as indicated on details.
The staff shall be 1" ridged aluminum conduit or tubing with a wall thickness of 1/8 inch.

COLORS
The colors shall conform with the standard colors adopted by the American Association Of State Highway and Transportation Officials and approved by the U.S. Department Of Transportation, Federal Highway Administration.

MOUNTING
The staff shall be mounted with either 2-1/4" aluminum bolts or 2-1/4" aluminum rivets.

SIGN PADDLE FOR FLAGPERSON

NOTES

APPLICATION OF STANDARDS
Since it is not possible to prescribe detailed standards of application for all of the situations that may conceivably arise on a construction project, reference must be made to the Manual on Uniform Traffic Control Devices for the principles, procedures and standards that will be required in connection with on-project construction signs and barricades. The signs here shown represent a sample of those that probably will be most used.

DESIGN
The designs of the signs and barricades shall conform with the details shown on this sheet and with the standards prescribed in the Manual. Deviations will not be permitted.

MATERIALS
The signs shall be of metal, wood, plywood, hardwood or any other material satisfactory to the Engineer. No material will be approved that will deteriorate by exposure to the weather during the required life of the sign.

REFLECTORIZATION AND COLORS
All signs except sign R11-2 and the sign paddle shall have black texts and borders on an encapsulated lens reflective orange background. Sign R11-2 shall have black text and border on an encapsulated lens reflective white background.

INSTALLATION
Signs and barricades shall be in place prior to the start of the construction operation to which they apply, and shall be removed promptly when the need no longer exists. Each sign shall be erected in a neat and workmanlike manner on wood or metal posts set securely in the ground, or on portable supports for temporary use, or on barricades when appropriate. As a general rule, roadside signs shall be 5 feet above road level with the nearest edge at least 6 feet outside the shoulder point. The installation of all signs and barricades shall be subject to the approval of the Engineer.

MAINTENANCE
Signs shall be kept in a clean and legible condition at all times with the reflective quality completely unimpaired. Signs, sign supports, and barricades shall be repaired, cleaned, repainted or replaced whenever necessary. Weeds, shrubbery, construction materials, equipment, and snow shall not be allowed to obscure any sign or barricade. The maintenance of all traffic control devices shall be subject to the orders of the Engineer.

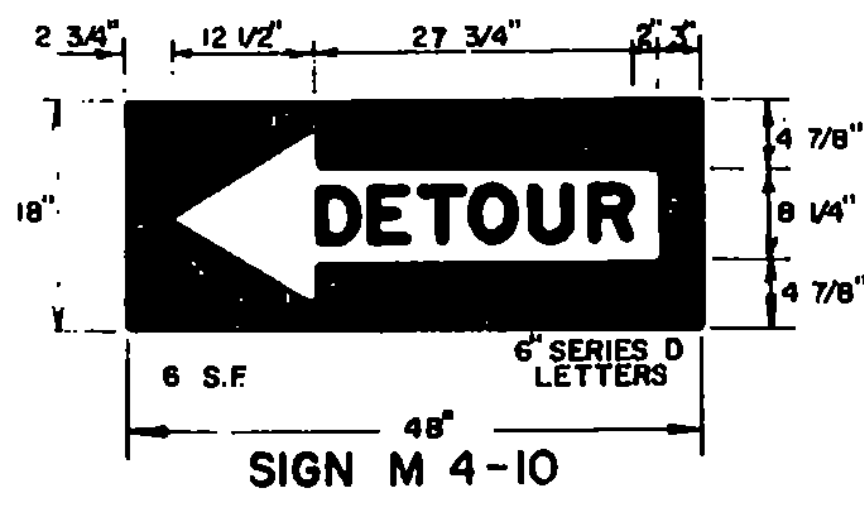
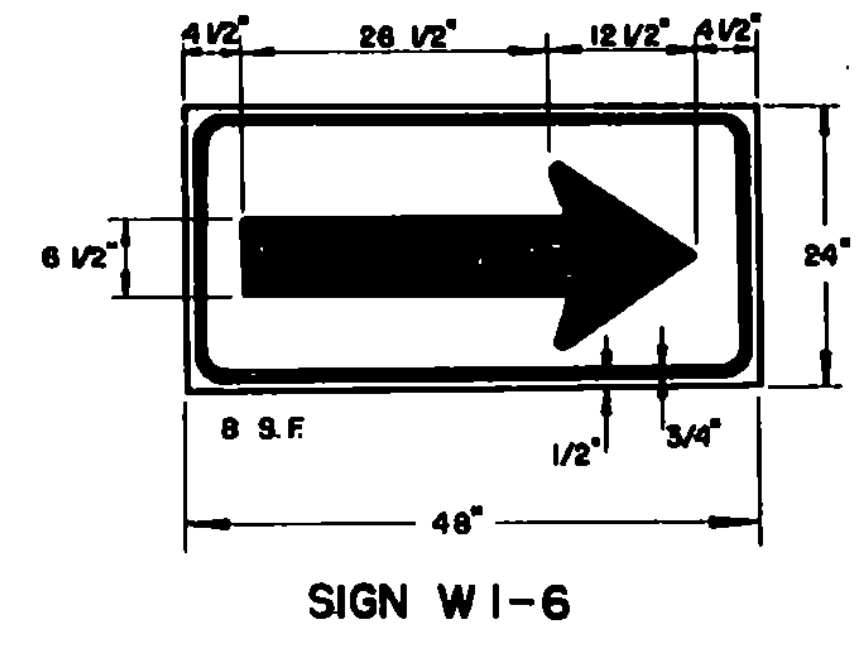
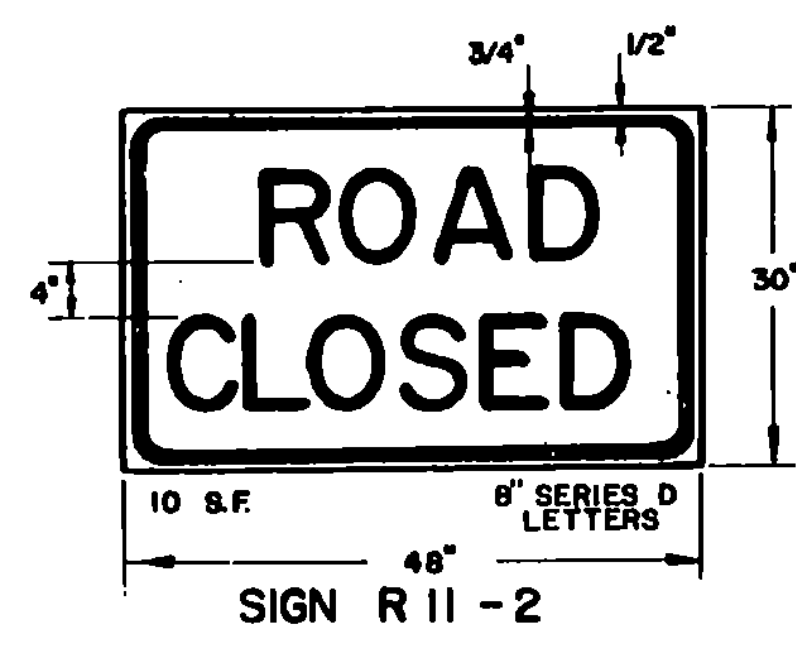

The on-project construction signs covered by this sheet are intended to be used as the situations apply within normal two-lane highway construction areas, for the protection of the public and workmen and for the guidance of traffic through or around construction operations. When messages other than those shown here are needed, the signs and their applications shall conform with the standards set forth in the Manual on Uniform Traffic Control Devices.

The cost of furnishing, erecting, maintaining and removing all construction approach signs shall be considered as subsidiary work pertaining to the project as a whole and shall be included in the contract unit price bid for various items involved in the contract.

REVISIONS AND CORRECTIONS
DEC. 14, 1973 - BEADS ON PAINT FOR BACKGROUND MATERIAL REMOVED.
MAY 14, 1974 - REFLECTIVE MATERIAL CHANGE.
JUNE 7, 1977 - REFLECTIVE MATERIAL NOTE CHANGED.
JUNE 7, 1977 - SIGNS REFERENCED TO NUMBERS IN M.U.T.C.D.
APR. 20, 1978 - FLAGPERSON SIGN CHANGED TO SYMBOL.
DEC. 19, 1978 - ILLUMINATION DELETED.
FEB. 27, 1980 - SIGN W1-8 AND SIGN PADDLE ADDED. SIGN DETAILS REVISED.
APR. 1, 1980 - SIGN PADDLE SIGN REVISED.
FIG. 3, 1986 - UPDATED TO 1986 SPECIFICATIONS

APPROVED
Dec. 14, 1971
DATE
R. H. Arnold
CHIEF ENGINEER
E. W. Stickney
ASST. CHIEF ENGINEER
G. M. Lane
HIGHWAY ENGINEER

TRAFFIC SIGNS
ON-PROJECT CONSTRUCTION SIGNS

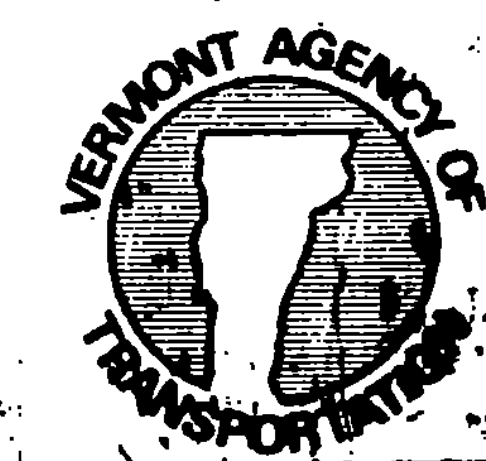

STANDARD
E-6