

VT GAS SPECIFICATIONS AND REQUIREMENTS WORKING IN THE VICINITY OF GAS LINES

- 1.) All damages to VGS gas lines shall be immediately reported to VGS inspectors. The damages shall be repaired by VGS street personnel prior to backfilling.
- 2.) All coating damage to steel gas lines shall be reported immediately to VGS inspectors. Coating breaks shall be repaired by either VGS street personnel or by contractors via VGS inspection prior to backfilling.
- 3.) All breaks and damages to tracer wire for plastic pipe shall be reported to VGS inspectors. The breaks and damages shall be repaired by either VGS personnel or by contractors via VGS inspection prior to backfilling.
- 4.) All damages to VGS cathodic protection facilities and (cathodic protection test facilities) shall be reported to VGS inspectors. The damages shall be repaired and tested by VGS personnel prior to backfilling.
- 5.) All damages to VGS test, locator, and valve boxes shall be reported to VGS inspectors. The damages shall be repaired by either VGS personnel or contractors via VGS inspection. All VGS test, locator, and valve boxes shall be brought up to grade prior to final paving, sidewalk and topsoil work. No boxes shall be under cover.
- 6.) Contractors are to conform to VGS separation distances and requirements. No concrete shall be in contact with gas lines. Extra coating required for steel gas lines shall be done by VGS personnel or contractors via VGS inspection prior to backfilling.
- 7.) All exposed gas lines shall be reported to VGS inspectors. All exposed gas lines shall be supported if necessary in accordance with VGS support standards. Supports shall be inspected by VGS personnel. All exposed gas lines shall be padded with 6 inches minimum of sand prior to backfilling unless otherwise stated by VGS specifications or drawings.

VERMONT GAS SYSTEMS, INC.

SEPARATION DISTANCES & REQUIREMENTS FOR UTILITIES & UNDERGROUND STRUCTURES

I. Horizontal Separation:

Three feet minimum separation between gas and utilities/underground structures.

II. Vertical Separation:

- A) One foot preferred vertical separation between gas and utilities/underground structures - six inch sand padding around gas. Three inch minimum sand padding around gas when vertical separation is six inches or less from gas and utilities/underground structure.
- B) Special provisions required for vertical separation between gas and utility duct system.
- C) Double coat and pad steel gas pipe within six inches or less vertical separation from utilities/underground structures. Gas pipe to be padded with three inches minimum of sand. Double coat steel gas pipe only if utility/underground structure is metal, wire, cable, conduit, or concrete.

III. Locator Wire:

Locator wire for plastic gas lines shall not be in contact with any utility or underground structure.

VERMONT GAS SYSTEMS, INC.

PIPELINE SUPPORT STANDARDS

Table of Separation Distances Between Supports
Steel and Plastic Pipe Only

Pipe Size	Maximum Separation Distance
1/2"	5'
3/4"	6'
1"	7'
1 1/2"	8'
2"	10'
4"	14'
6"	17'
8"	20'
10"	22'

HORIZONTAL SEPERATION--GAS FROM UTILITIES / UNDERGROND STRUCTURES

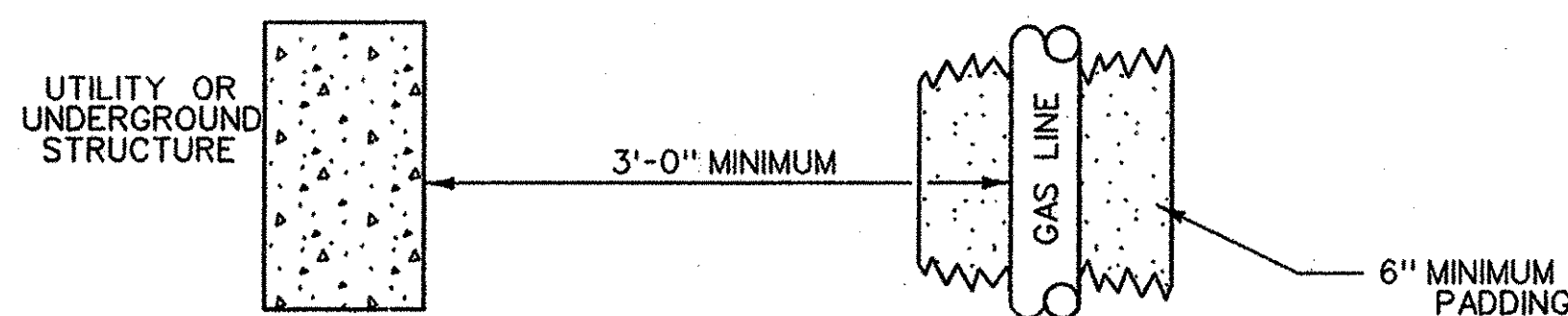

NOTES

1. No concrete in contact with gas pipe.
2. Padding sand only.
3. Drop inlets, manholes, vaults, AND POLES can be less than 3' from gas provided gas is not in contact with these structures. Min. 6" sand padding around gas pipe. Rock shield to be placed between these structures and gas when separation distance 1' or less. Steel gas pipe to be double coated when separation distance 1' or less.
4. Pads, pedestals, transformers, etc. cannot be directly over gas lines. Min. 2' horizontal separation from edge of these facilities and gas. Min. 6" sand padding around gas when exposed. (See Below)
5. * Rock shield shall be furnished by VGS.

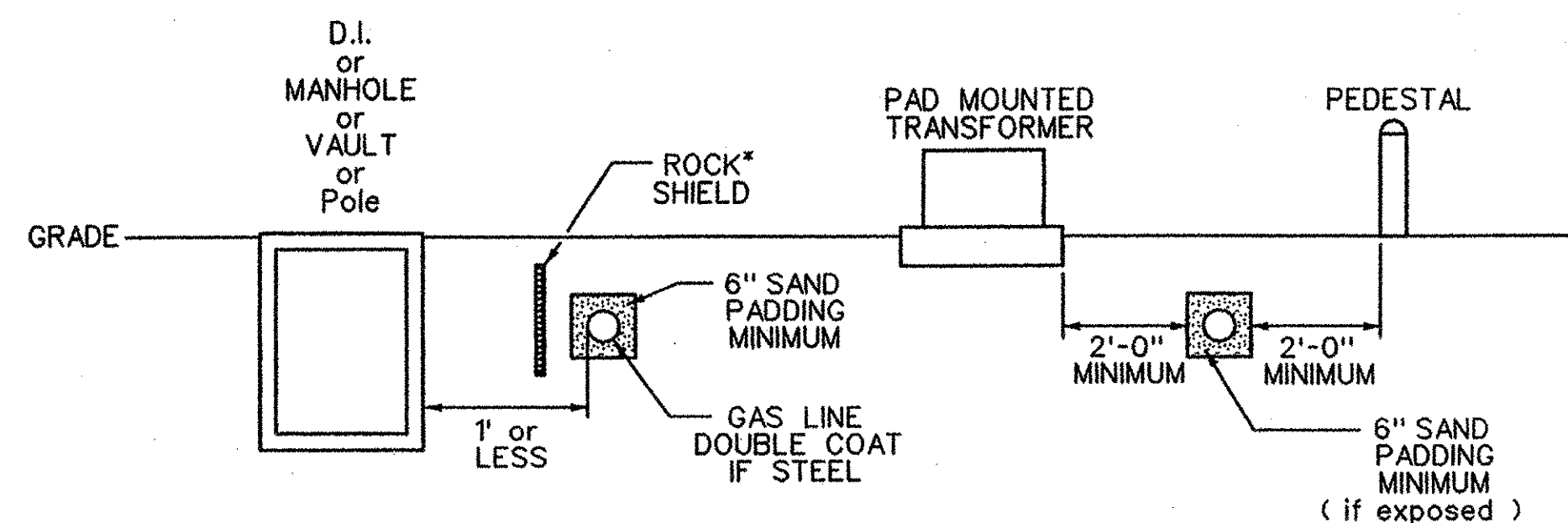

VERTICAL SEPERATION--GAS FROM UTILITIES / UNDERGROND STRUCTURES

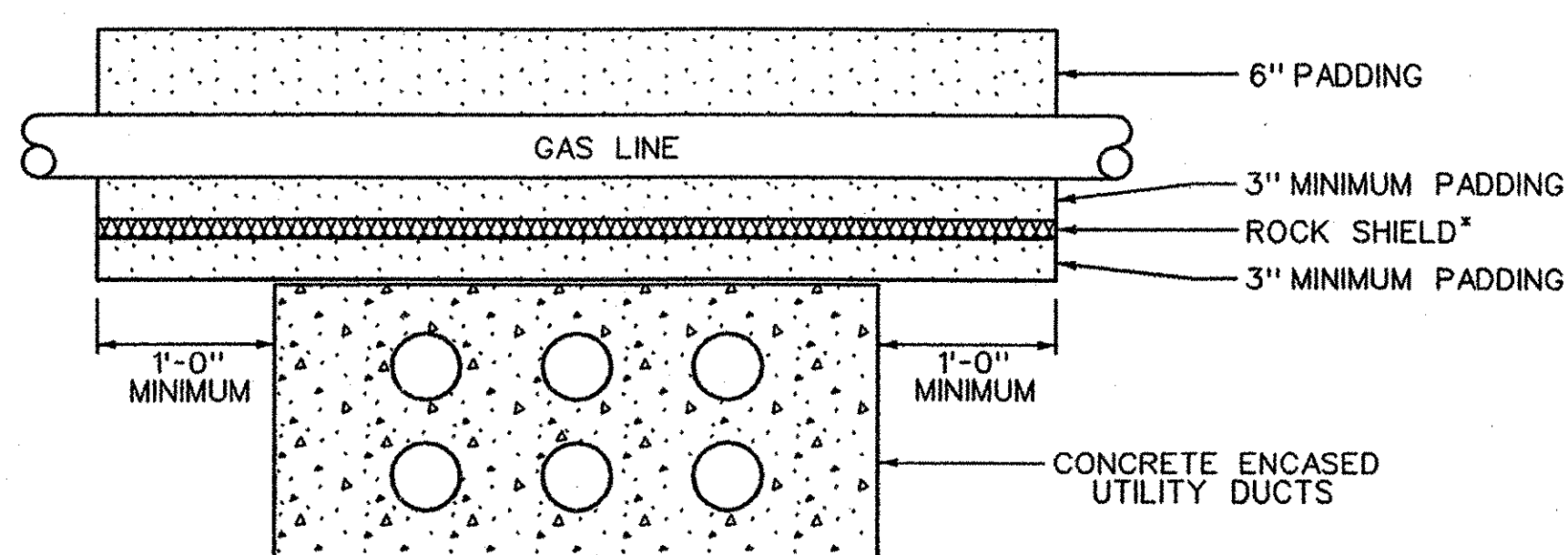

GAS LINE ABOVE DUCT

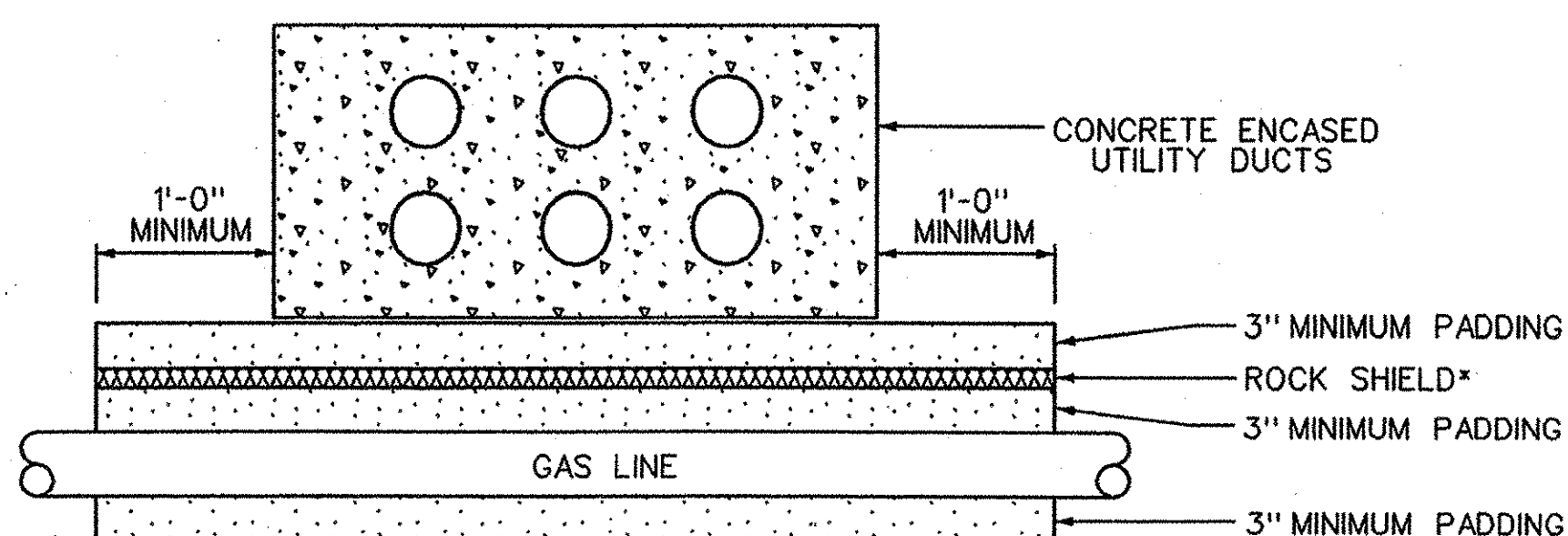

GAS LINE BELOW DUCT

VERMONT GAS PIPELINE SUPPORT STANDARDS

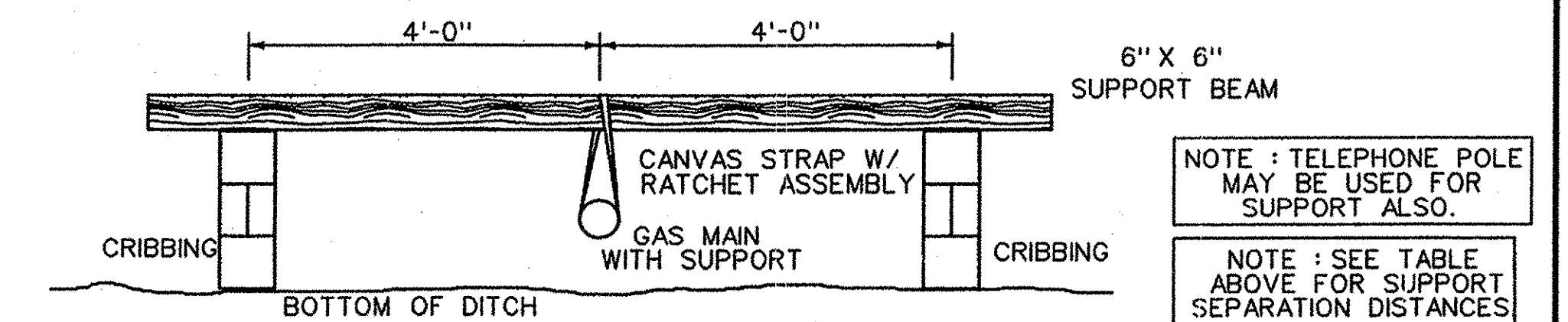

CROSS SECTION - GAS MAIN SUPPORT - OPEN EXCAVATION

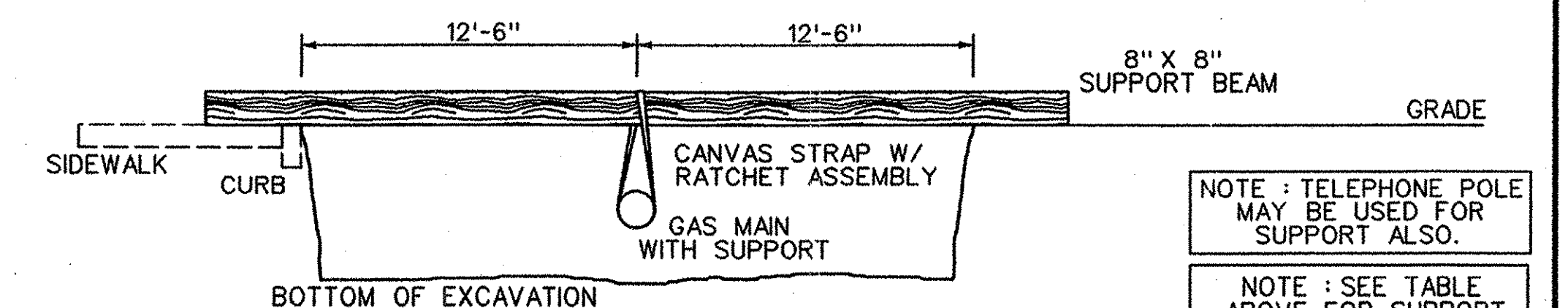

CROSS SECTION - GAS MAIN SUPPORT W/ HALF OF ROAD EXCAVATED. (50' ROAD EXAMPLE)

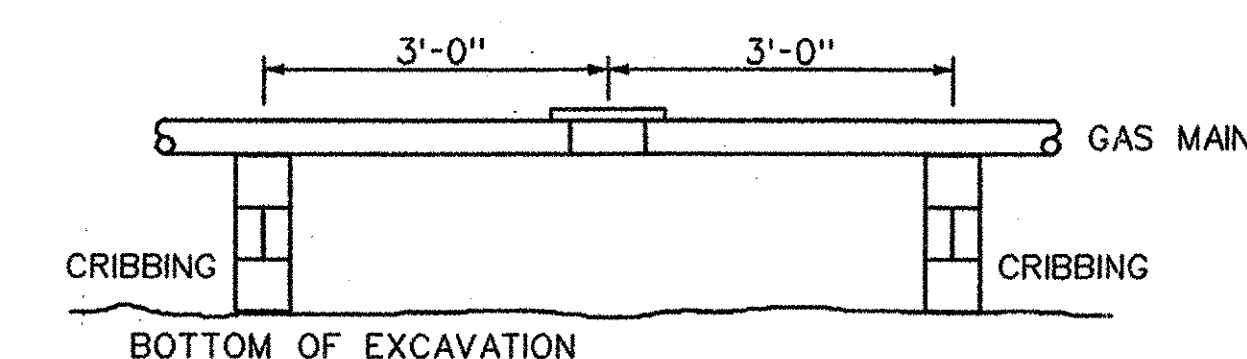

PROFILE - GAS MAIN SUPPORT W/ MECHANICAL JOINT

NOT TO SCALE

DRAWN BY SHANGRAW DATE JAN. '94
 DESIGN FILE NO. /CMU/GRAW/GAS.DGN
 IPARM FILE /CMU/GRAW/GAS.i PLOTTED
 PROJECT NAME: BURLINGTON
 PROJECT NUMBER: MEGC 5000(15)
 SHEET 169 OF 252 SHEETS