

POST CONNECTION
HAND RAIL SECTION

POST CONNECTION
ELEVATION

POST CONNECTION
BARRIER RAIL SECTION

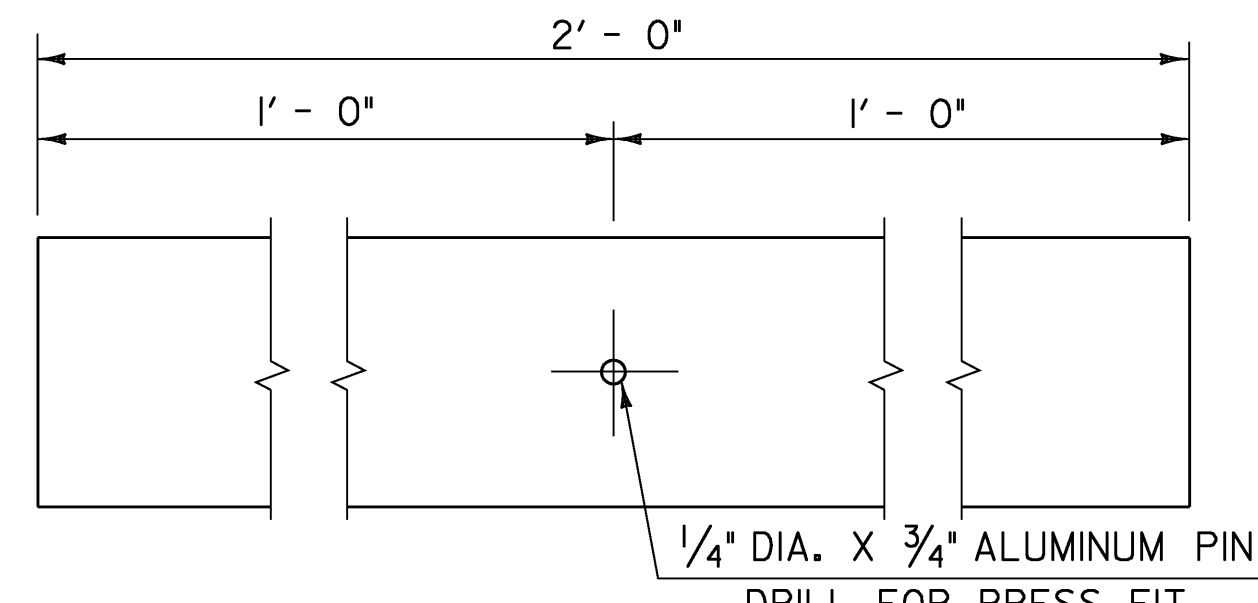
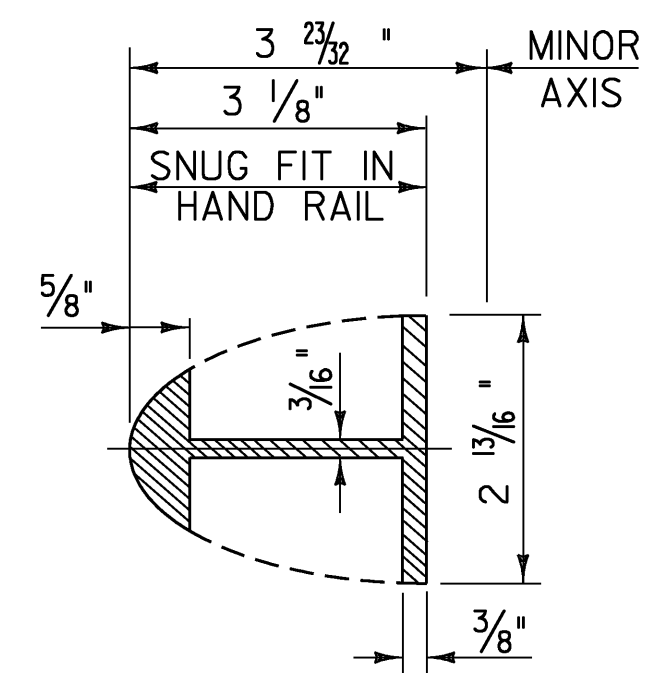

HAND RAIL
SPLICE SECTION

ELEVATION OF
HAND RAIL SPLICE BAR

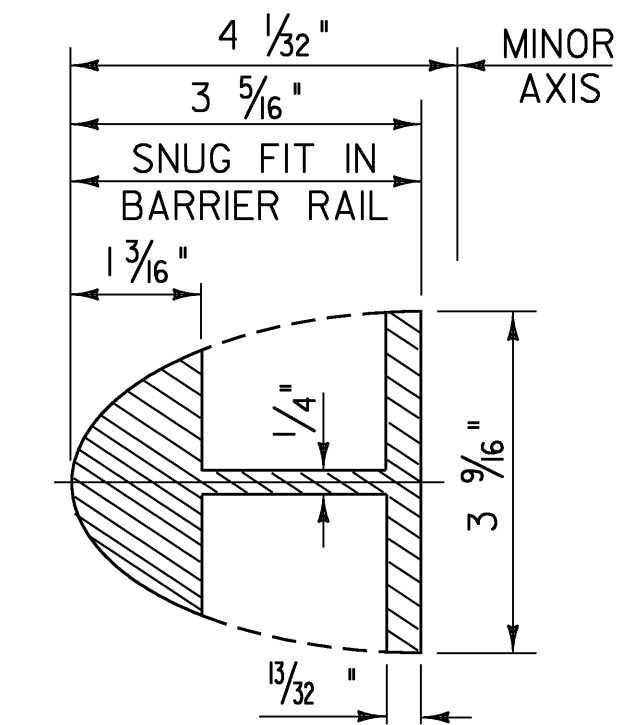

BARRIER RAIL
SPLICE SECTION
(SEE THIS SHEET FOR ELEVATION
OF BARRIER RAIL SPLICE BAR)

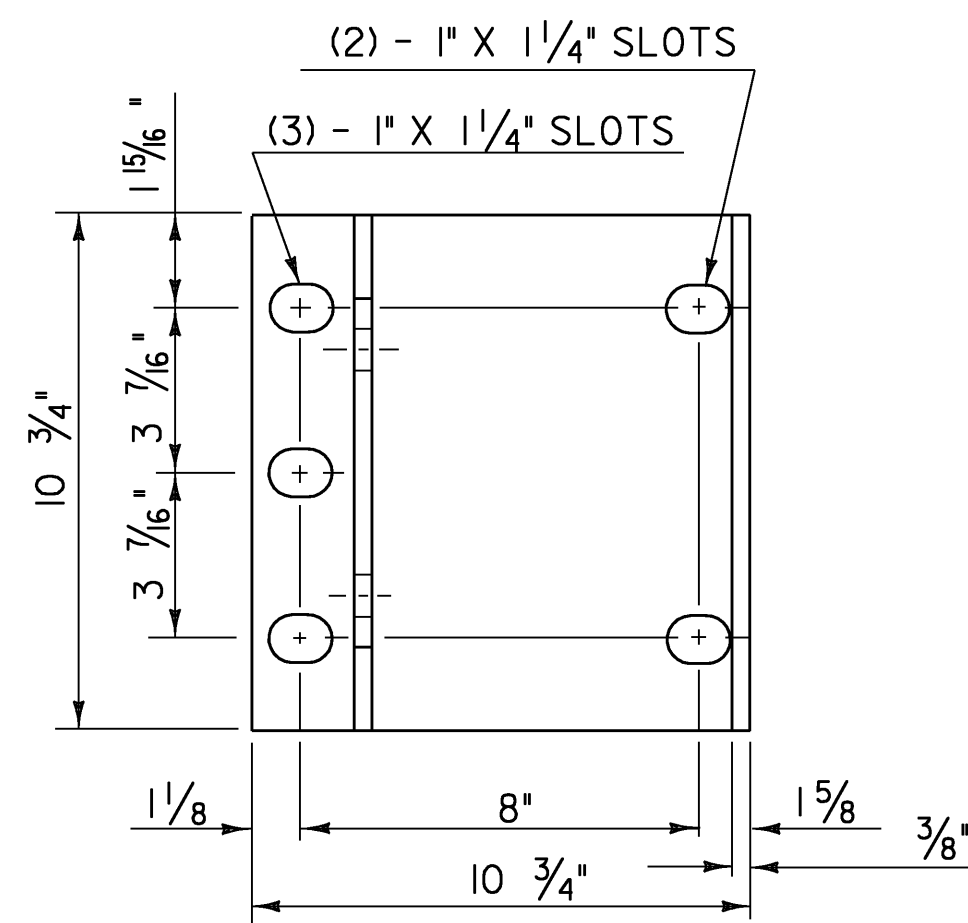

POST BASE
PLAN
(WINGWALL 4 ONLY)

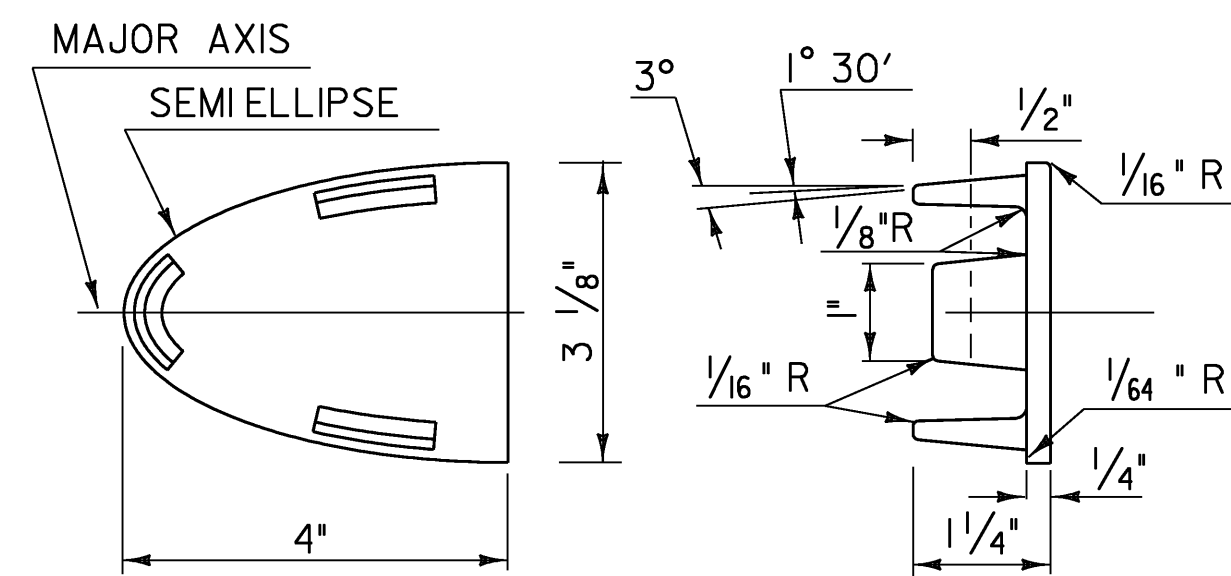

HAND RAIL END CAP

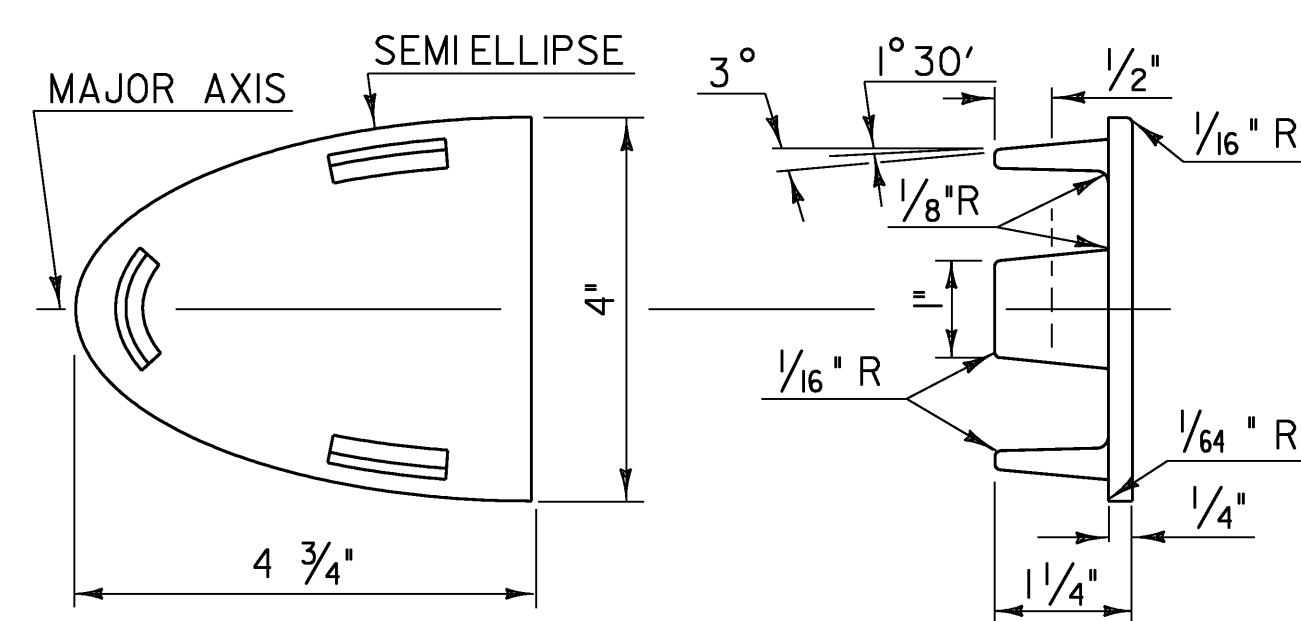

BARRIER RAIL END CAP

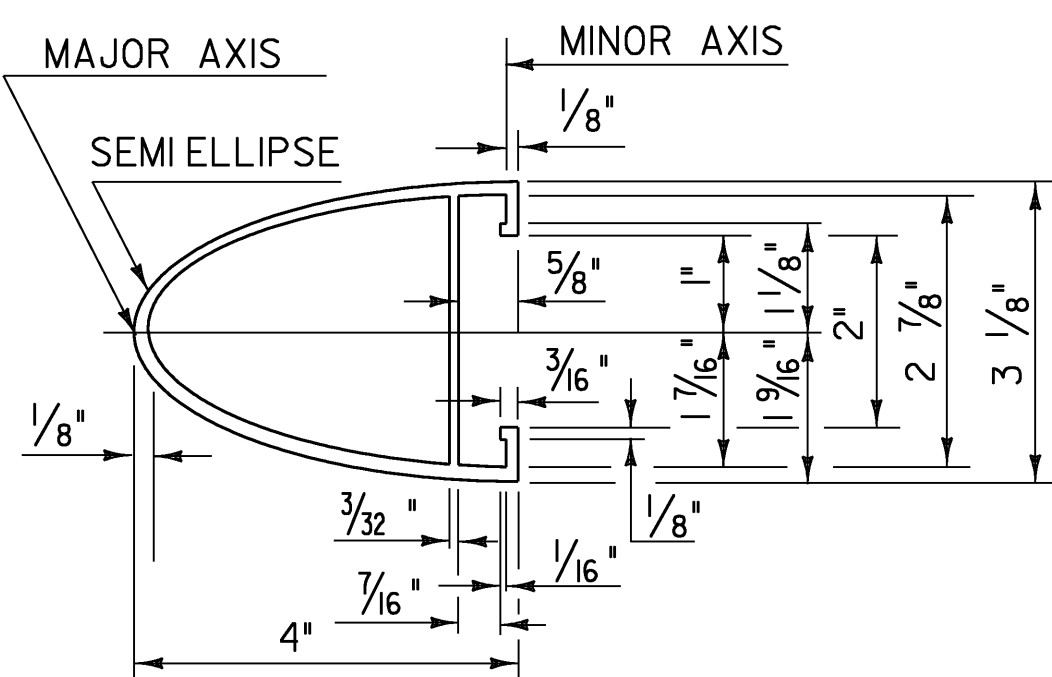

HAND RAIL SECTION

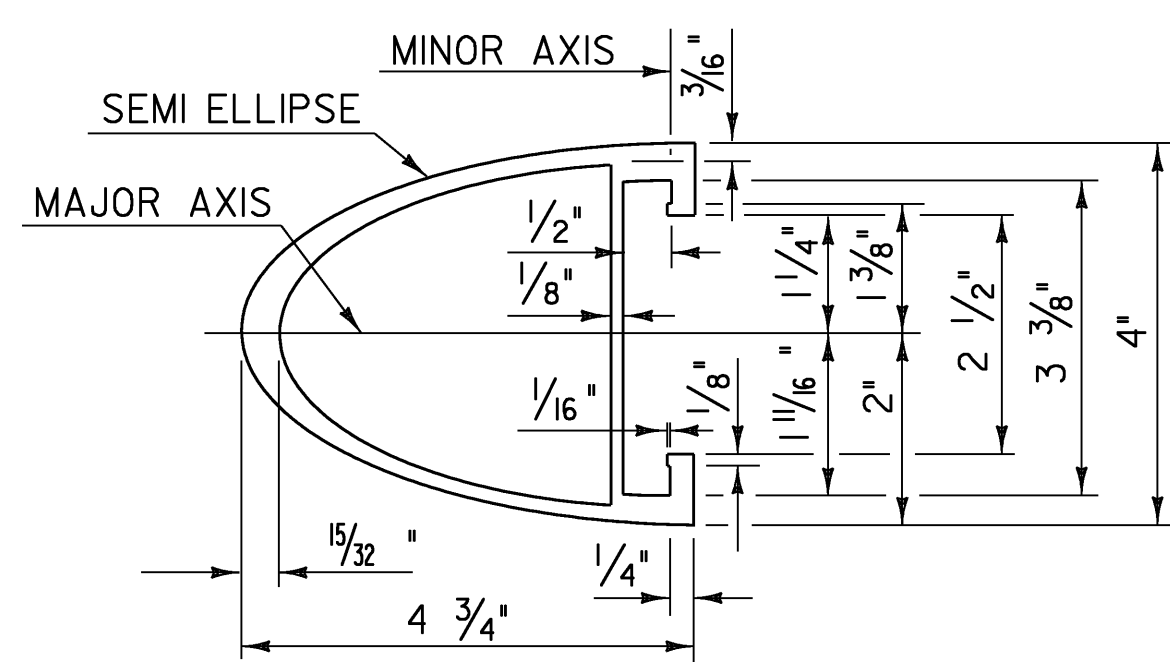

BARRIER RAIL SECTION
(SEE SHEET 33 FOR ELEVATION
OF BARRIER RAIL)

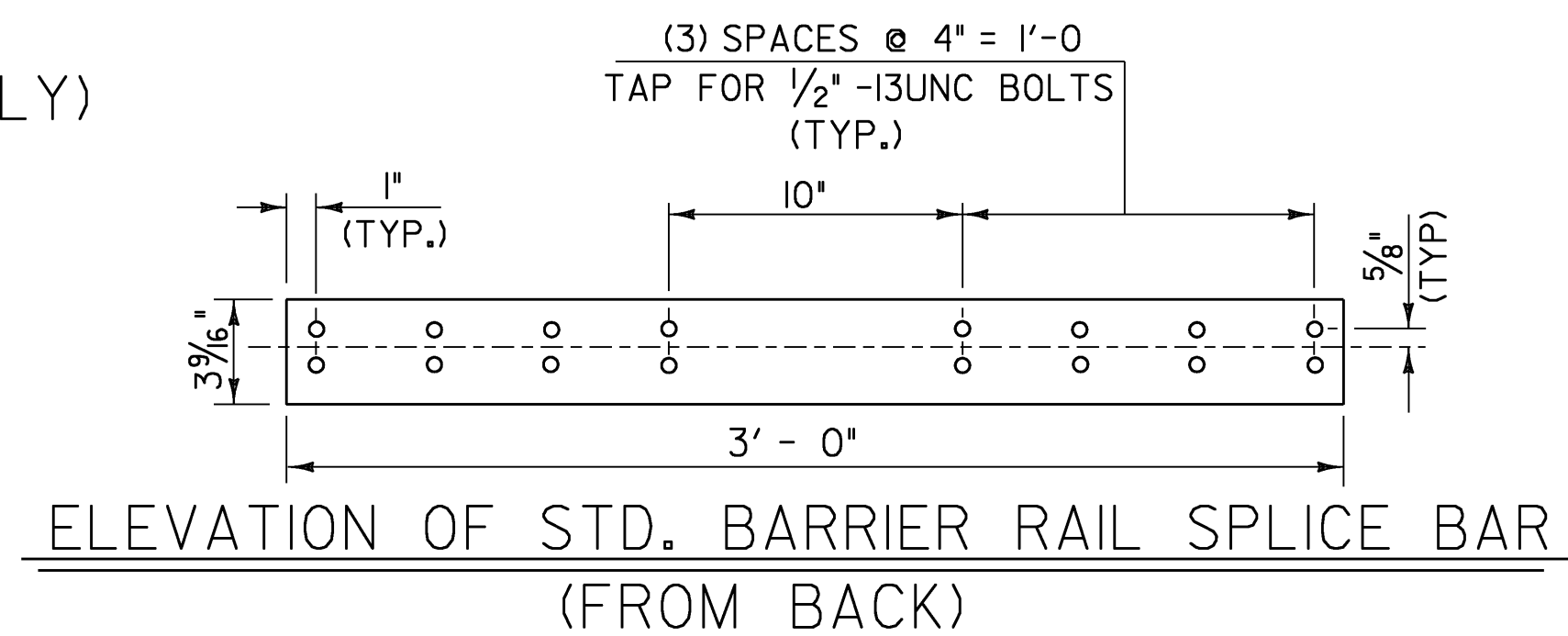

ELEVATION OF STD. BARRIER RAIL SPLICE BAR
(FROM BACK)

NOTES

- ANCHOR BOLTS, NUTS AND WASHERS SHALL CONFORM TO SUBSECTION 714.07.
- ALUMINUM SPLICE BARS, CONNECTION BARS, RAILS AND BALLUSTER FRAMES SHALL CONFORM TO ASTM B221, ALLOY 6061-T6 OR ALLOY 6351-T5. MINIMUM ALLOWABLE STRESS $F_y = 35,000$ psi. RAIL POSTS SHALL CONFORM TO ASTM B 308/ B 308M.
- ALUMINUM BALUSTER TUBES SHALL CONFORM TO ASTM B221/ALLOY 6061-T4 OR 6063-T4.
- ALUMINUM RAIL END CAPS SHALL CONFORM TO ASTM B26 ALLOY 356-T6.
- THE POST, RAIL, AND OFFSET BLOCK CONNECTION BOLTS AND SET SCREWS SHALL CONFORM TO SUBSECTION 732.02 (b).
- WELDING SHALL CONFORM TO THE REQUIREMENTS OF SUBSECTION 506.10.
- UNLESS OTHERWISE SPECIFIED, ANCHOR BOLTS SHALL BE CAST INTO THE CONCRETE AS DETAILED.
- WHENEVER FEASIBLE, BARRIER RAIL AND HAND RAIL SECTIONS SHALL BE FULL LENGTH SECTIONS (40'±) AND WHEN POSSIBLE SHALL BE ATTACHED TO THREE POSTS. RAILS SHALL BE SPLICED AT EACH DECK JOINT AND INTERMITTENTLY AS REQUIRED. SPLICES SHALL OCCUR WITHIN THE SAME PANEL.
- ENDS OF RAILS SHALL BE CUT SQUARE AND GROUND FREE OF BURRS OR RAGGED EDGES. EXPOSED ENDS SHALL BE CAPPED.
- EXTRUDED SECTIONS ARE DETAILED TO COMPLY WITH CURRENT AASHTO-AGC-ARTBA STANDARDS. MINOR VARIATIONS OF THE DETAILS SHOWN MAY BE CONSIDERED PROVIDING THEY DO NOT REDUCE THE STRENGTH CAPACITY OF THE RAIL SYSTEM.
- ALUMINUM PLATE WASHERS SHALL BE ASTM B209 ALLOY ACLAD 2024-T4.
- THE RAILING SYSTEM AND ASSOCIATED HARDWARE SHALL BE ANODIZED TO A BLACK SATIN FINISH EXCEPT AS NOTED, SEE SPECIAL PROVISIONS.

ALUMINUM RAILING DETAILS
(SHEET 5)

PROJECT NAME: FAIRFAX	PLOT DATE: 17-JUL-2009
PROJECT NUMBER: BHF 023-I(5)	DRAWN BY: str-3
FILE NAME: /86e064/str/se064rail.dgn	DESIGNED BY: C. CARLSON
PROJECT LEADER: C. CARLSON	CHECKED BY: C. CARLSON
DESIGNED BY: C. CARLSON	SHEET 32 OF 61
FILE NAME: /86e064/str/se064rail5.i	