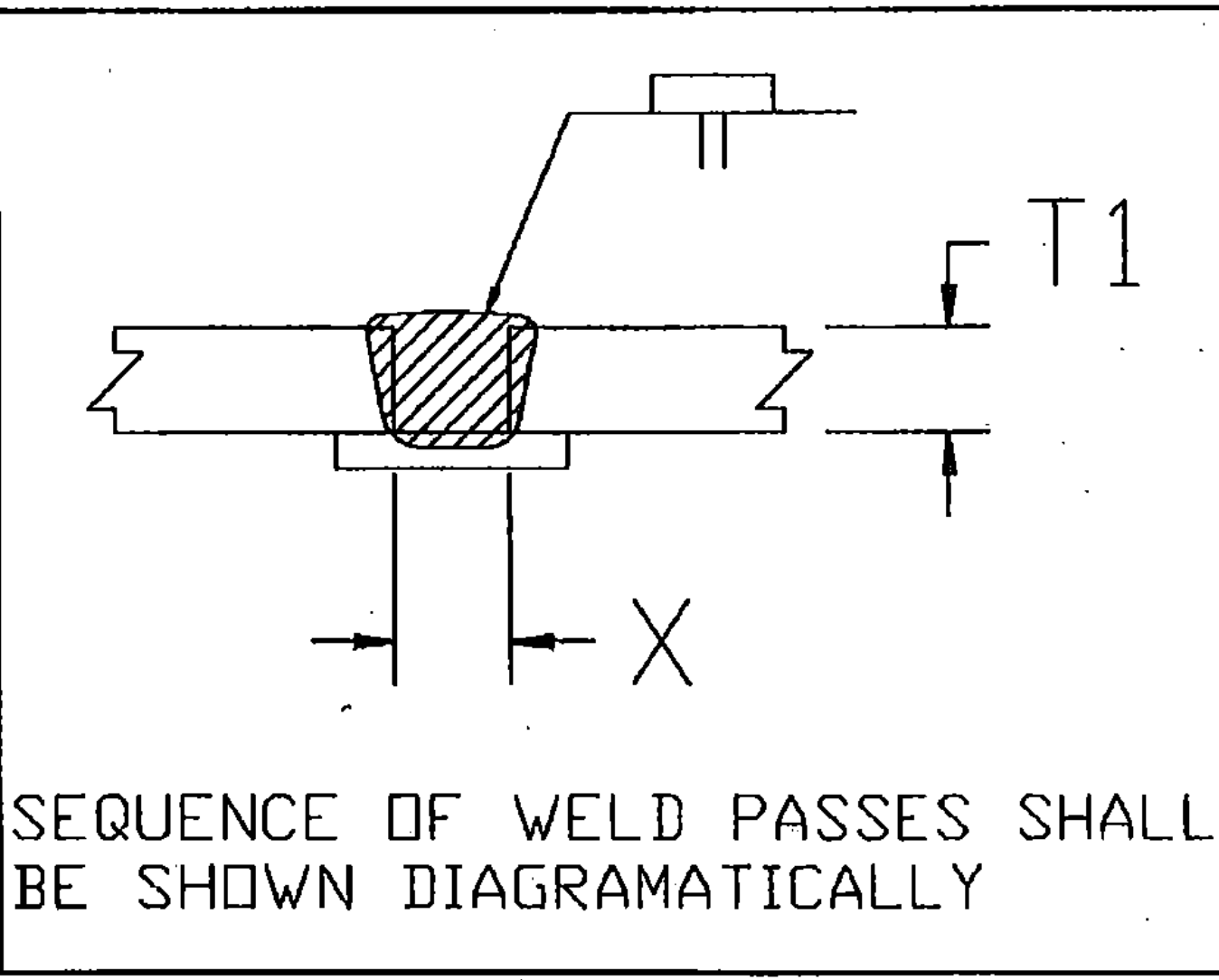

193 BRIDGE  
RAILING

**WELDING PROCEDURE SPECIFICATION**

Material Specification	PQR# ELDERLEE#3
Welding Process	A500 GR B
Manual or Machine	FCAW
Position of Welding	SEMAUTOMATIC
Filler Metal Specification	FLAT
Filler Metal Classification	A5.20 - 95
Flux	E71T-1H8 E71T-9H8 LINCOLN ULTRACORE
Shielding Gas	N/A
Single or Multiple Pass	CO 2 Dew Point -40DEG F Flow Rate 50CFH
Single or Multiple Arc	SINGLE
Welding Current	SINGLE
Polarity	DC
Welding Progression	(REVERSE) ELECTRODE POSITIVE
Root Treatment	STRINGER
Preheat and Interpass Temperature	CLEAN AS PER SECTION 603 OF THE NYSSCM
Postheat Temperature	PREHEAT AS PER TABLE 708 OF THE NYSSCM
Heat Input	NONE
	Min _____ Max _____

**WELDING PROCEDURE**

Pass no.	Electrode size	Welding Current		Travel speed	Joint detail
		Amperes	Volts		
1	1/16	300	26	14	 <p>SEQUENCE OF WELD PASSES SHALL BE SHOWN DIAGRAMATICALLY</p>
Variable	LIMITS	270	24	12.6	
		TO 330	TO 28	TO 15.4	

This procedure may vary due to fabrication sequence, fit-up, pass size, etc., within the limitation of variables given in Section 5.

Procedure No. 3004 Contractor Elderlee, Inc.  
 Revision No. \_\_\_\_\_ Authorized By RANDY SCOTT  
 Date 6/21/2010