

TYPICAL SECTION AT GIRDERS
SCALE 1/2" = 1'-0"

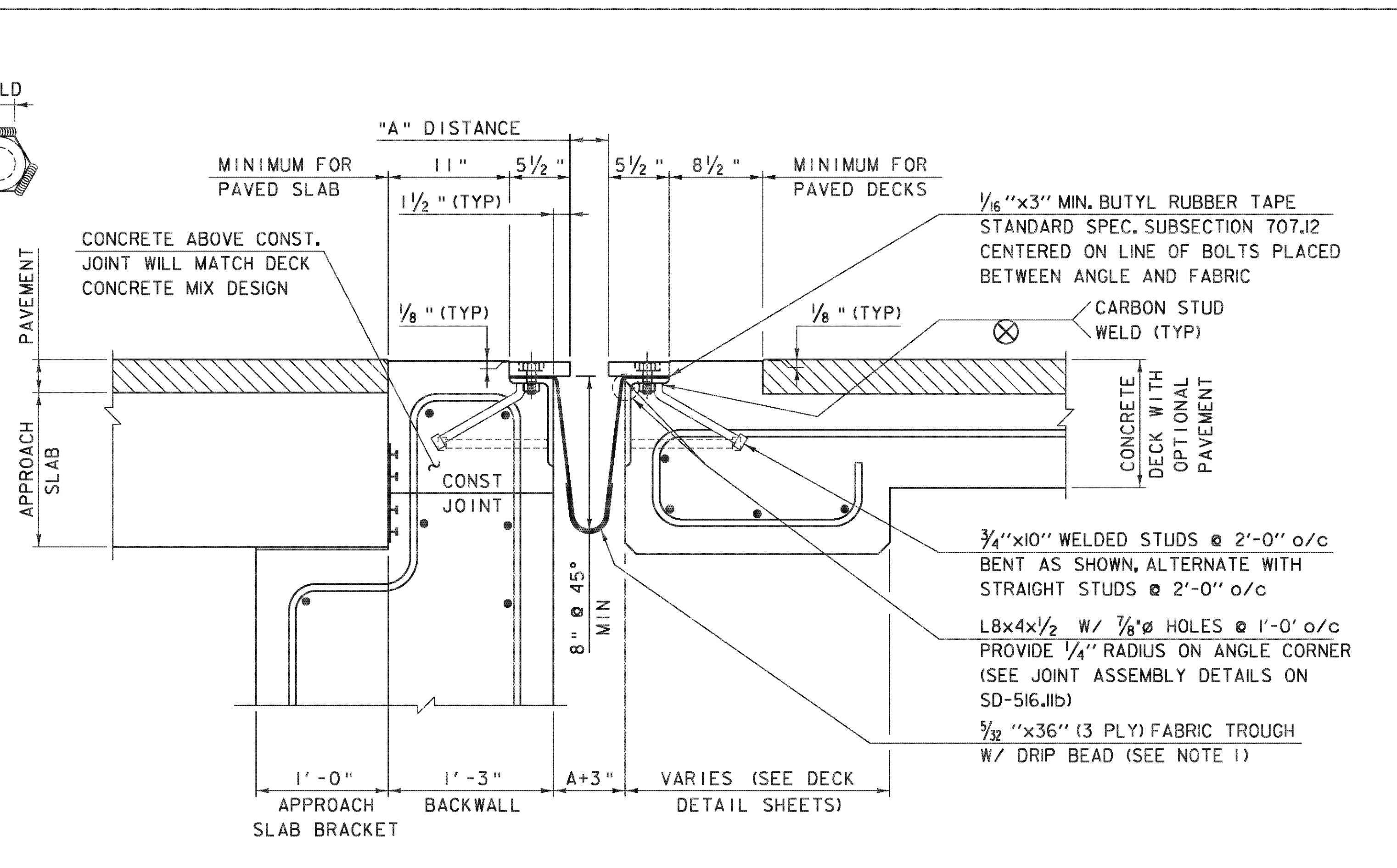

TYPICAL SECTION BETWEEN GIRDERS
SCALE 1/2" = 1'-0"

NOTES FOR ITEM 516.11 "BRIDGE EXPANSION JOINT, VERMONT"

- FABRIC TROUGH SHALL BE THOROUGHLY CLEANED AND FLUSHED AFTER PAVING OPERATION. A DRIP BEAD OF 1/4"x7" STRIP OF PREFORMED FABRIC MATERIAL SHALL BE CEMENTED TO THE BOTTOM OF THE FABRIC TROUGH USING AN ADHESIVE APPROVED BY THE MANUFACTURER. THE DRIP BEAD SHALL BE APPLIED 1" FROM THE DOWNSPOUT END OF THE TROUGH. PREFORMED FABRIC MATERIAL SHALL BE CONTINUOUS FOR THE FULL LENGTH OF THE JOINT.
- THE EXPANSION DEVICE SHALL BE COVERED TO PROTECT THE FINISH DURING PLACING OF BRIDGE DECK CONCRETE.
- SEE "JOINT GAP DIMENSION TABLE" FOR DISTANCE "A" VALUES IN TEMPERATURE RANGE PROVIDED.
- JOINT BRACKET LENGTH "X" VARIES DEPENDENT ON THE BRIDGE SKEW ANGLE. THE BRACKET MUST BE LOCATED SUCH THAT THE THREADED RODS ARE NOT LESS THAN 1/2" FROM GIRDERS END OR FLANGE SIDES.
- ALL STEEL COMPONENTS SHALL BE GALVANIZED OR METALIZED AND MEET THE REQUIREMENTS OF SUBSECTION 516.02. PRIOR TO GALVANIZING OR METALIZING, ALL CORNERS AND EDGES OF STEEL PLATES, SHAPES, ETC., SHALL BE GROUND TO A 1/16" INCH RADIUS. THREADED RODS SHALL CONFORM TO THE REQUIREMENTS OF 714.04. THE "WELDED STUD ANCHOR PLATE" AND WELDED STUDS MAY BE SUPPLIED WITHOUT GALVANIZING OR METALIZING.

- THE 4"x8"x1/2" ANGLES MAY BE FURNISHED AS ONE CONTINUOUS PIECE OR SPLICED AS SHOWN IN THE FIELD SPLICE DETAIL WHEN SPECIFIED. THE 1/4"x5 1/2" BARS EACH SIDE OF THE JOINT SHALL BE PROVIDED IN TWO EQUAL LENGTHS.
- PROJECTING THREADS OF THE 3/4" Ø BOLTS IN THE JOINT SHALL BE GREASED BY THE CONTRACTOR PRIOR TO PLACING ADJACENT CONCRETE. THIS WILL FACILITATE BOLT REMOVAL IF REQUIRED IN THE FUTURE.
- FILL COUNTERBORED HOLES WITH HOT POURED JOINT SEALER (STD. SPEC. 707.04) AFTER BOLT INSTALLATION. PAYMENT FOR THE WORK SHALL BE INCIDENTAL TO ITEM 516.11 "BRIDGE EXPANSION JOINT, VERMONT".
- THE EXPANSION JOINT, INCLUDING THE FABRIC TROUGH, SHALL BE SHOP ASSEMBLED AND SHIPPED AS ONE UNIT. IF THE EXPANSION JOINT HAS A FIELD SPLICE SPECIFIED, THE FABRIC TROUGH SHALL BE SHIPPED WITH ONE UNIT AND ASSEMBLED WITH THE SECOND UNIT PRIOR TO CONCRETE PLACEMENT.
- TEMPORARY SHIPPING ATTACHMENTS SHALL BE ATTACHED BY BOLTING; WELDING WILL NOT BE PERMITTED.
- BARE DECK "RISER PLATE" AS SHOWN IN "TYPICAL SECTION AT GIRDERS" DRAWING SHALL BE INCLUDED ON BRIDGES WITH BARE CONCRETE DECK SPECIFIED. RISER PLATES SHALL BE INCLUDED FOR BOTH SIDES AND MATCH THE LENGTHS OF THE 1/4"x5 1/2" BARS. THE RISER PLATE CAN BE REMOVED IF THE DECK IS MILLED IN THE FUTURE.

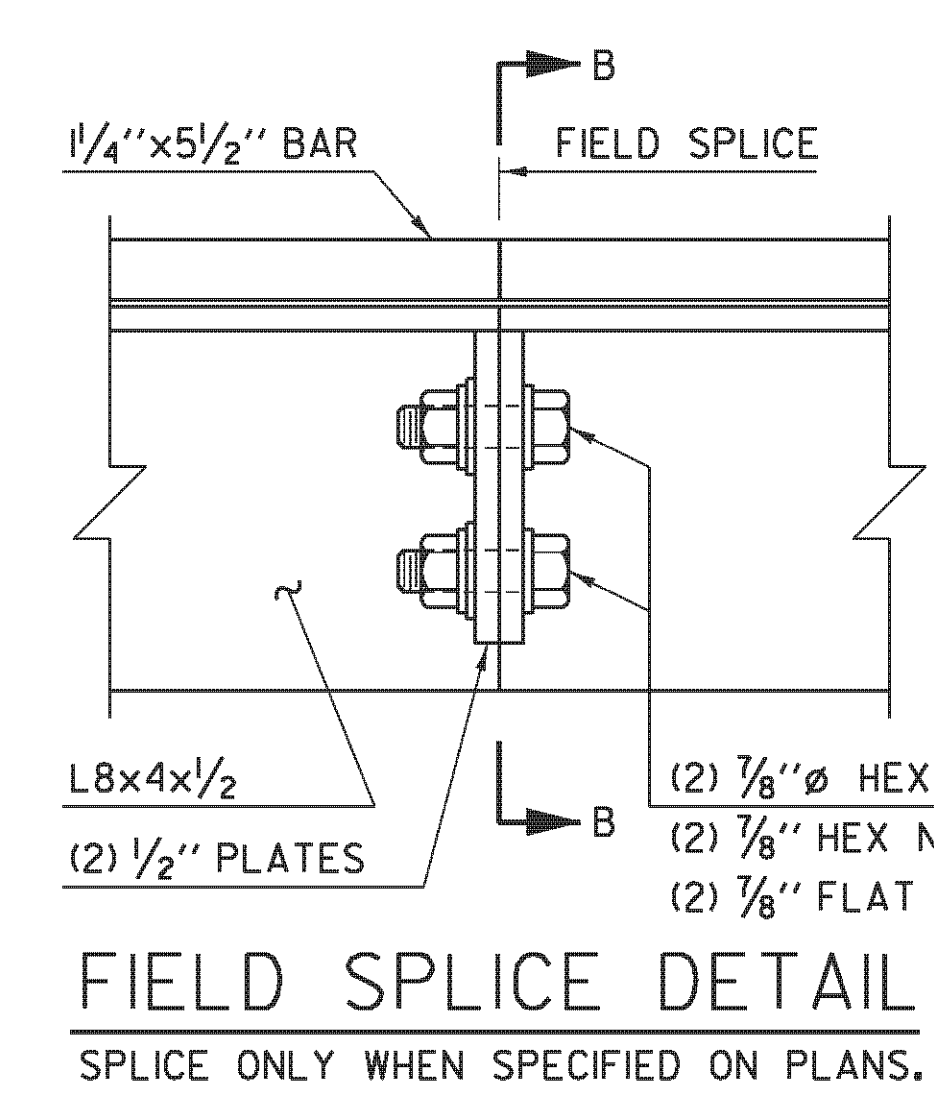

FIELD SPLICE DETAIL
SPLICE ONLY WHEN SPECIFIED ON PLANS.

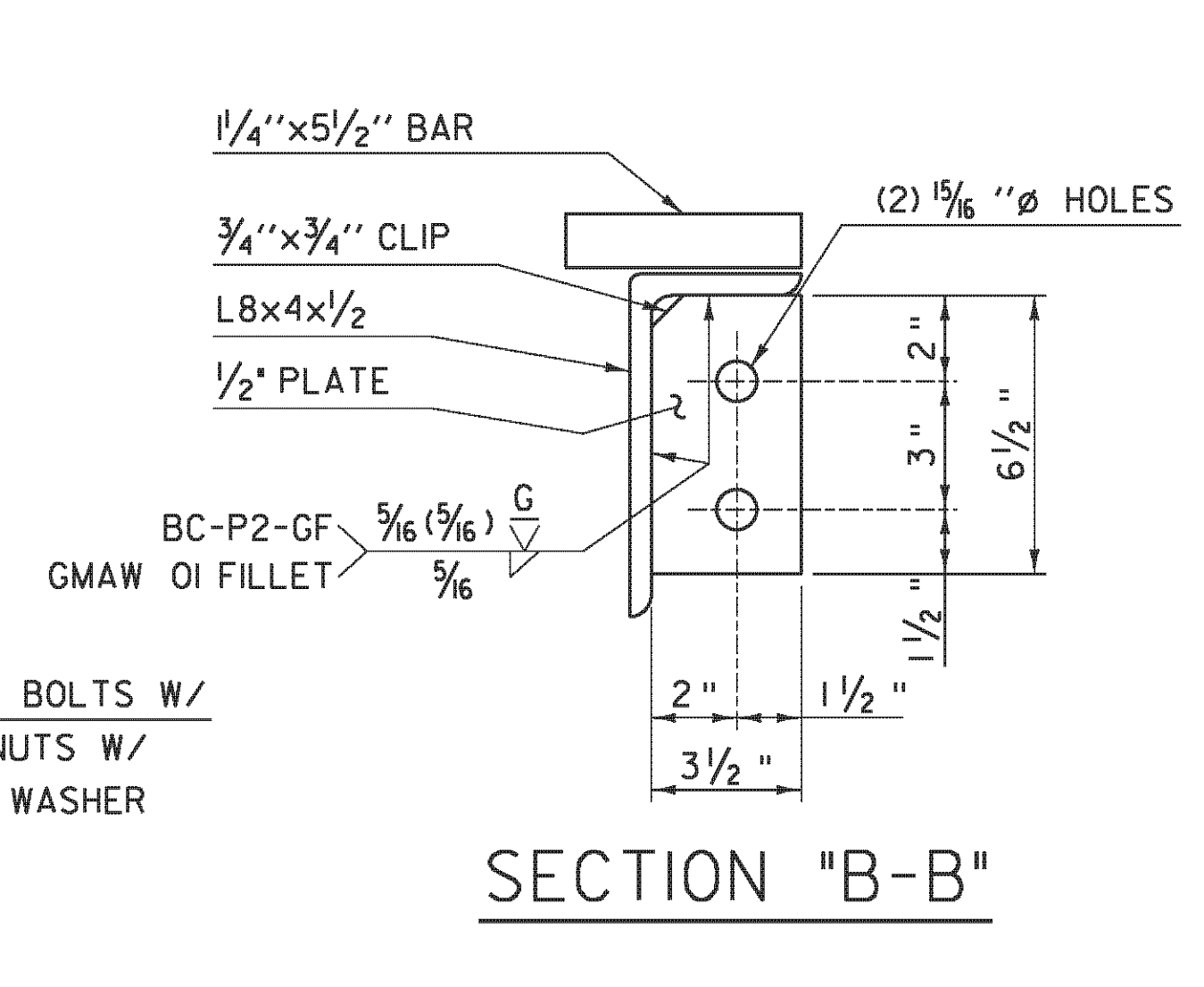

SECTION "B-B"

REVISIONS	
FEBRUARY 24, 2011	APPROVED FOR USE BY VAOT STRUCTURES SECTION

**BRIDGE EXPANSION JOINT,
VERMONT**

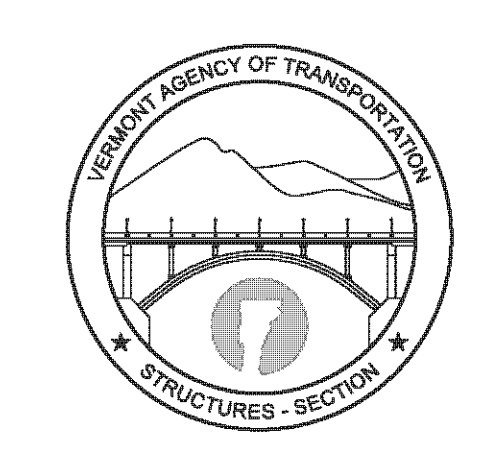

**STRUCTURES
DETAIL
SD-516.11a**