

**THRUST BLOCK DETAILS**  
NOT TO SCALE

THRUST BLOCK SCHEDULE  
SQUARE METERS OF CONCRETE THRUST  
BLOCKING BEARING ON UNDISTURBED MATERIAL

REACTION TYPE	PIPE SIZE											
	100mm	150mm	200mm	250mm	300mm	350mm	400mm	450mm	500mm	600mm	750mm	900mm
A	0.89	2.19	3.92	5.57	8.62	10.91	15.41	18.02	24.06	34.64	53.83	77.39
B	0.65	1.55	2.76	4.19	6.09	8.37	10.89	13.87	17.01	24.49	38.06	54.72
C	0.48	1.19	2.12	3.01	4.66	5.91	8.34	9.71	13.02	18.75	29.13	41.88
D	0.25	0.60	1.08	1.54	2.37	3.01	4.25	4.97	6.64	9.56	14.85	21.35
E	0.13	0.30	0.54	0.77	1.19	1.52	2.12	2.51	3.33	4.79	7.45	10.71

Other test pressures for the above reactions  
TEST PRESSURE TO BE 1380 kN/m<sup>2</sup> MIN. AT LOW END OF THE TEST SECTION.  
SQUARE METERS OF CONCRETE THRUST BLOCKING FOR OTHER TEST PRESSURES IS DIRECTLY PROPORTIONAL TO THE ABOVE TABLE.  
FOR INSTANCE, AT 1380 kN/m<sup>2</sup> TEST PRESSURE FOR ABOVE NUMBERS DOUBLE.

- NOTES:
- POUR THRUST BLOCKS AGAINST UNDISTURBED MATERIAL. WHERE TRENCH WALL HAS BEEN DISTURBED, EXCAVATE LOOSE MATERIAL AND EXTEND THRUST BLOCK TO UNDISTURBED MATERIAL. NO JOINTS SHALL BE COVERED WITH CONCRETE.
  - ON BENDS AND TEES, EXTEND THRUST BLOCKS FULL LENGTH OF FITTING.
  - PLACE CONCRETE PATIO BLOCKS IN FRONT OF ALL PLUGS BEFORE POURING THRUST BLOCK. COST INCIDENTAL TO CONCRETE.
  - REQUIREMENTS OF THE ABOVE TABLE PRESUME MINIMUM SOIL BEARING OF 96 kN PER SQUARE METER, AND MAY BE VARIED BY THE ENGINEER TO MEET OTHER CONDITIONS ENCOUNTERED.
  - MECA-LUC RETAINER GLANDS ARE REQUIRED FOR ALL MECHANICAL JOINTS. THESE GLANDS DO NOT REDUCE THE REQUIREMENTS FOR THRUST RESTRAINT.
  - ALL FITTINGS SHALL BE WRAPPED IN POLYETHYLENE OR BUILDING PAPER PRIOR TO INSTALLATION OF CONCRETE RESTRAINT.
  - THREADED ROD SHALL BE ANSI A242 F150 PIPE RESTRAINT NUTS TO MATCH AWWA C111. THREADED RODS AND NUTS TO BE FIELD COATED WITH BITUMINOUS PAINT.
  - THRUST RESTRAINT IS REQUIRED FOR ALL TEES, BENDS, REDUCERS, CAPS, PLUGS, OR CROSSES.
  - INSTALL LIFT HOOKS INTO THRUST BLOCKS AT END CAPS AND PLUGS. COST INCIDENTAL TO CONCRETE.

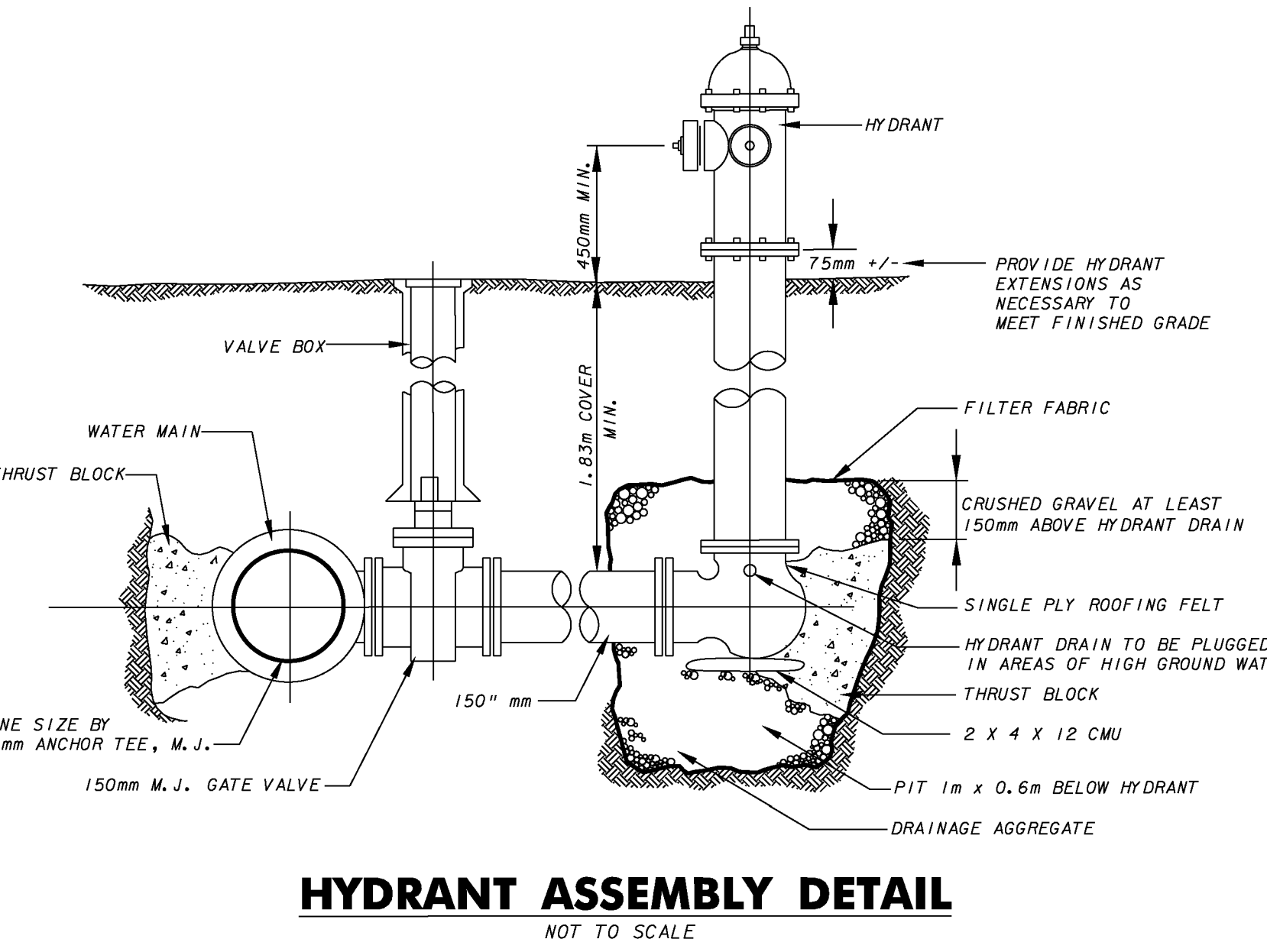
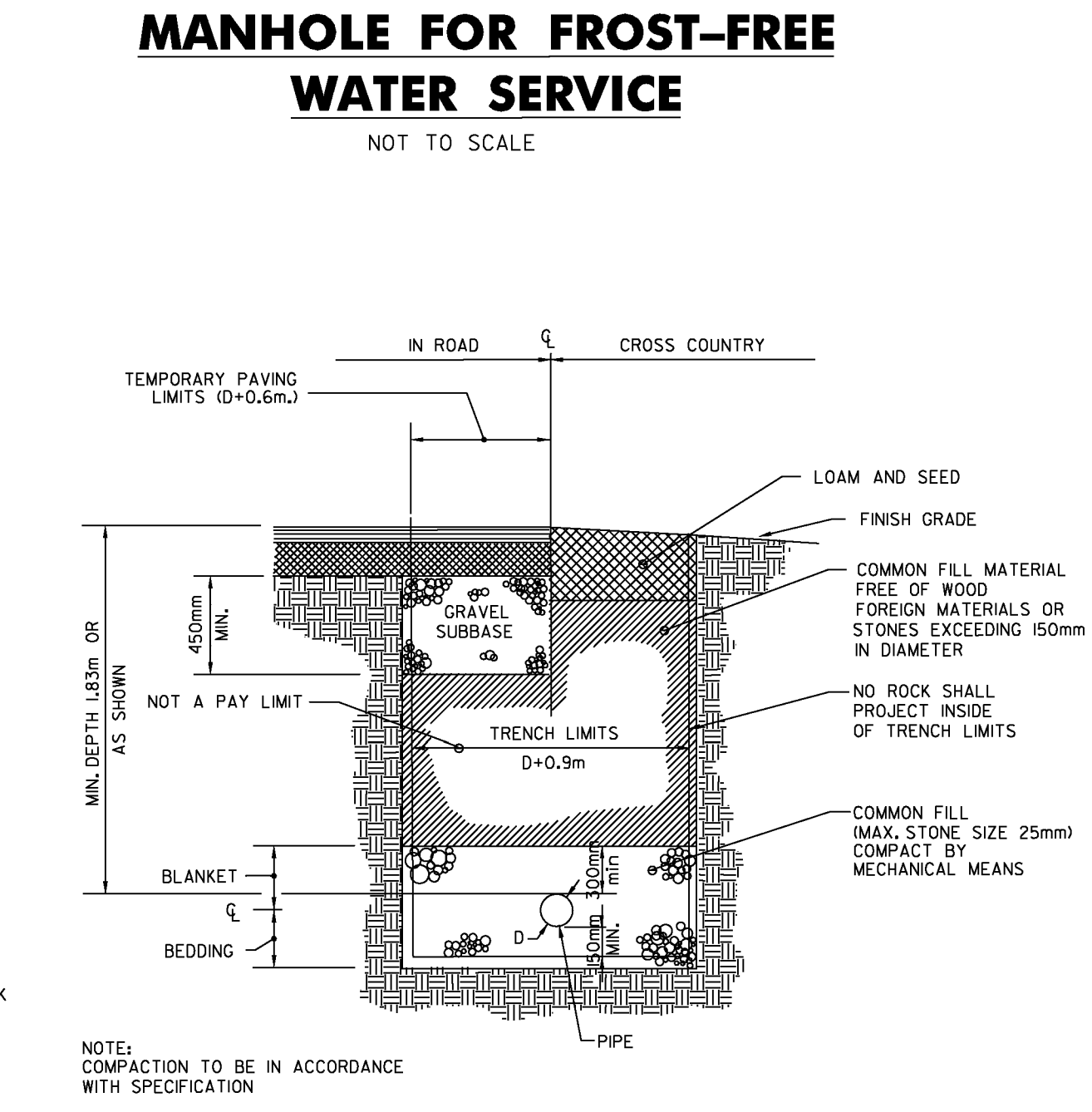
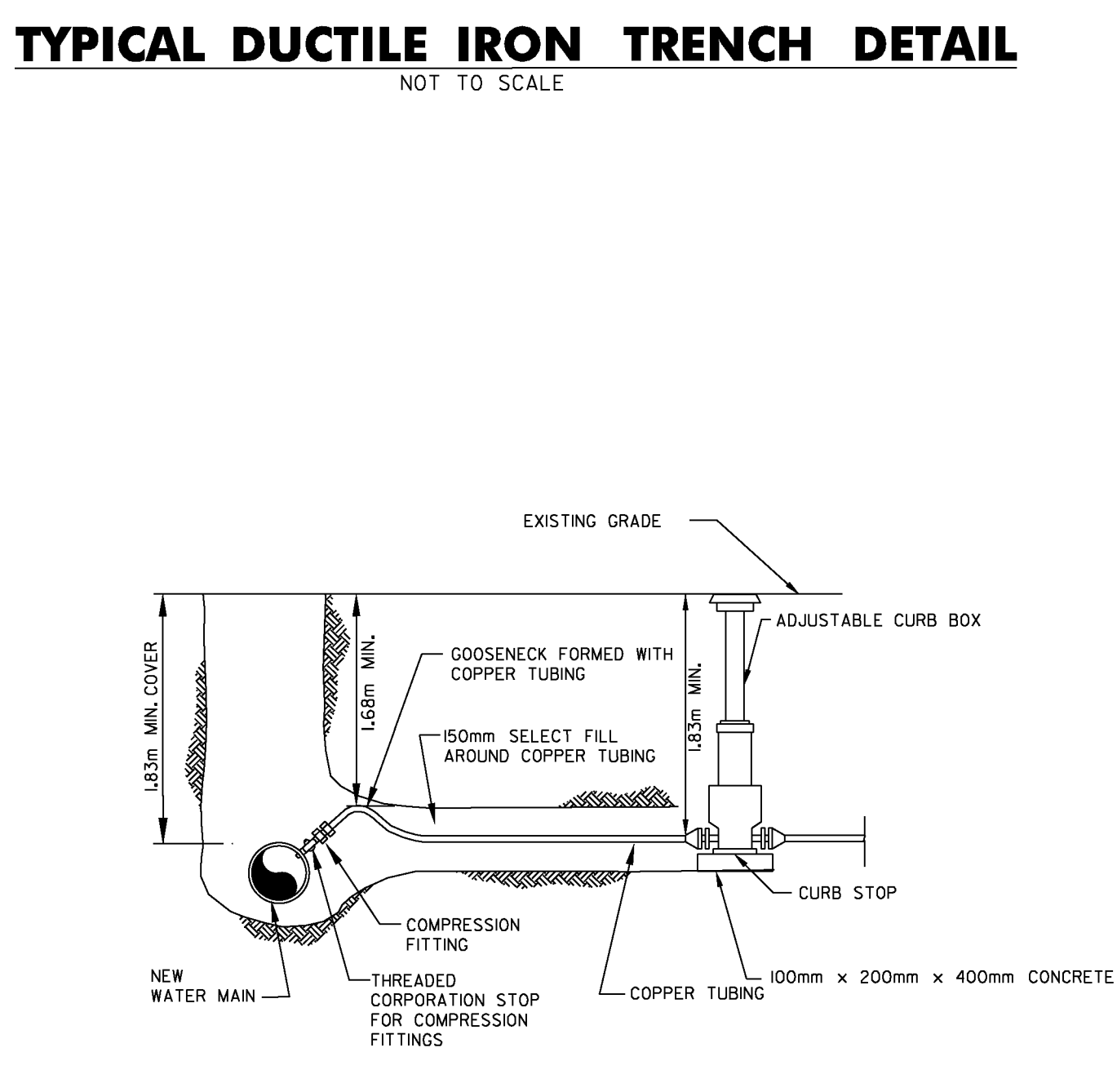
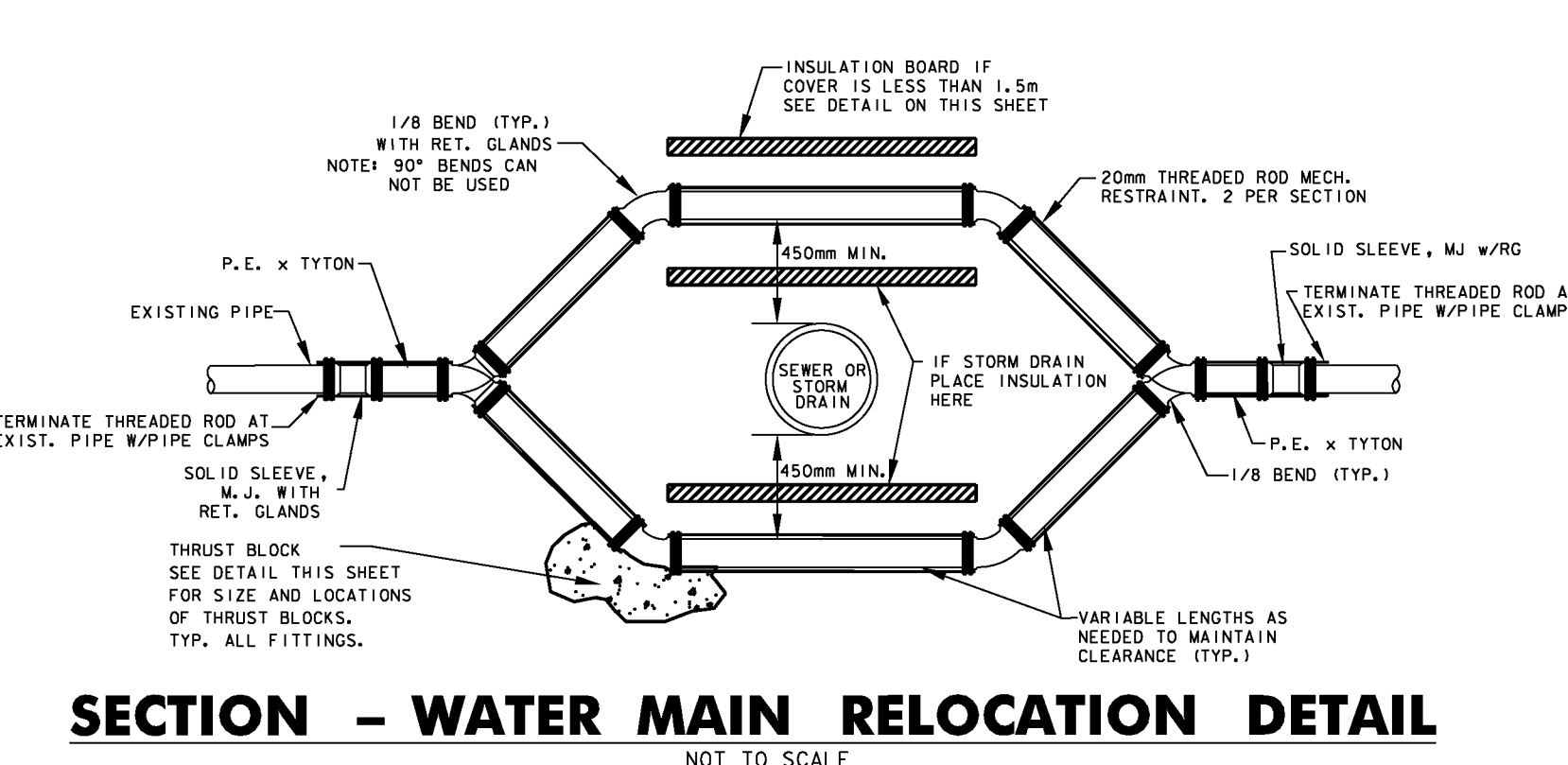
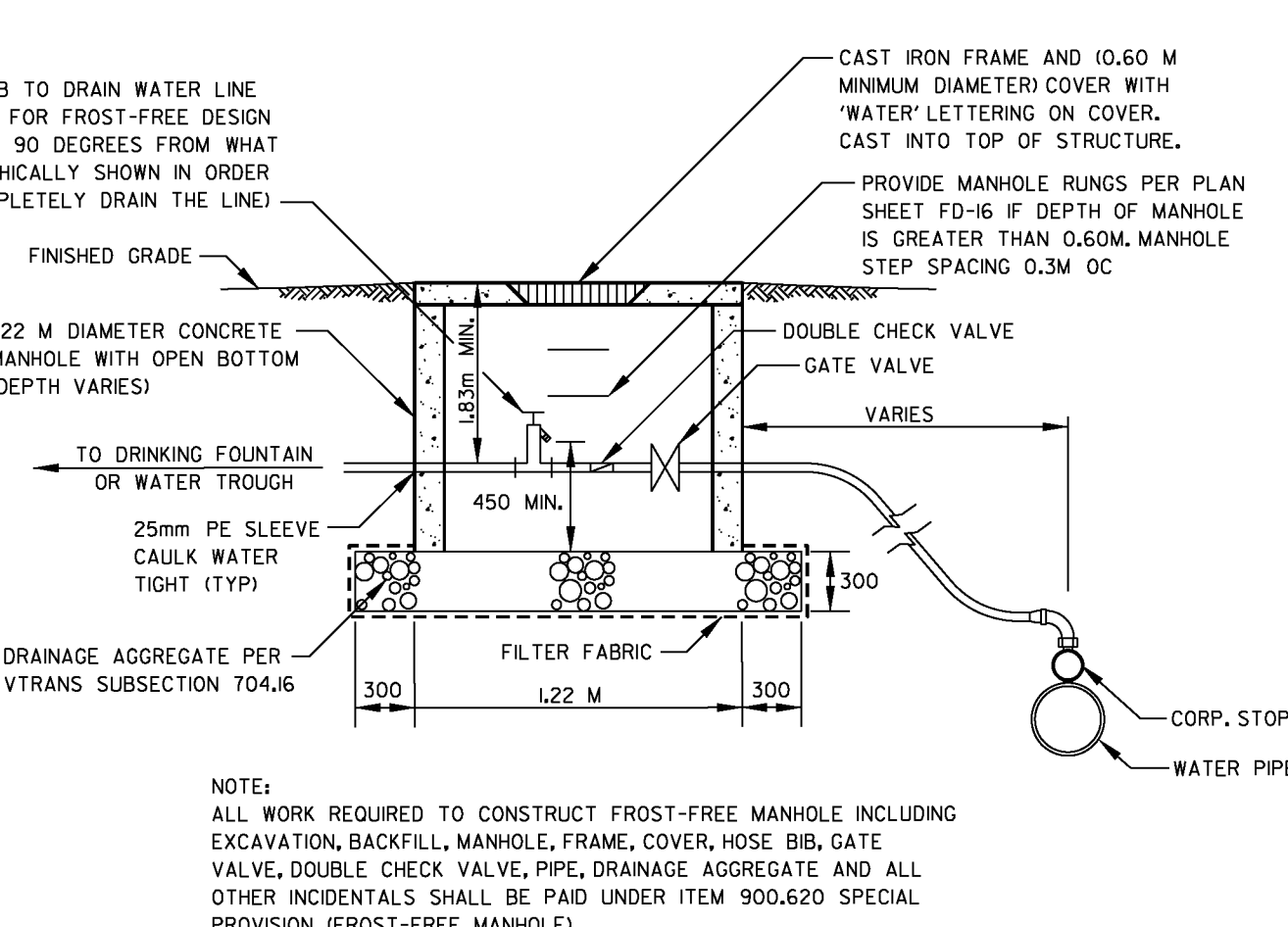
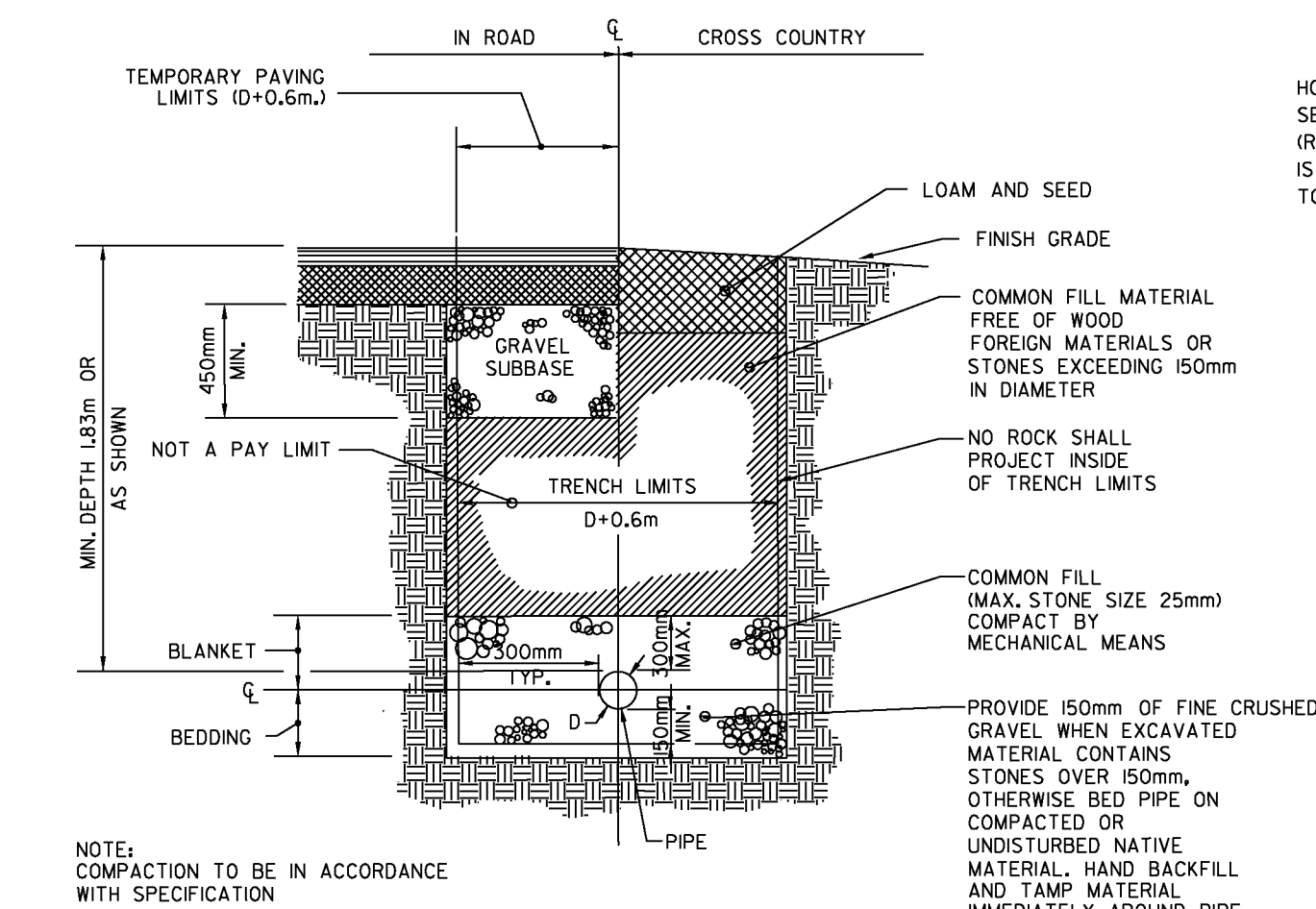
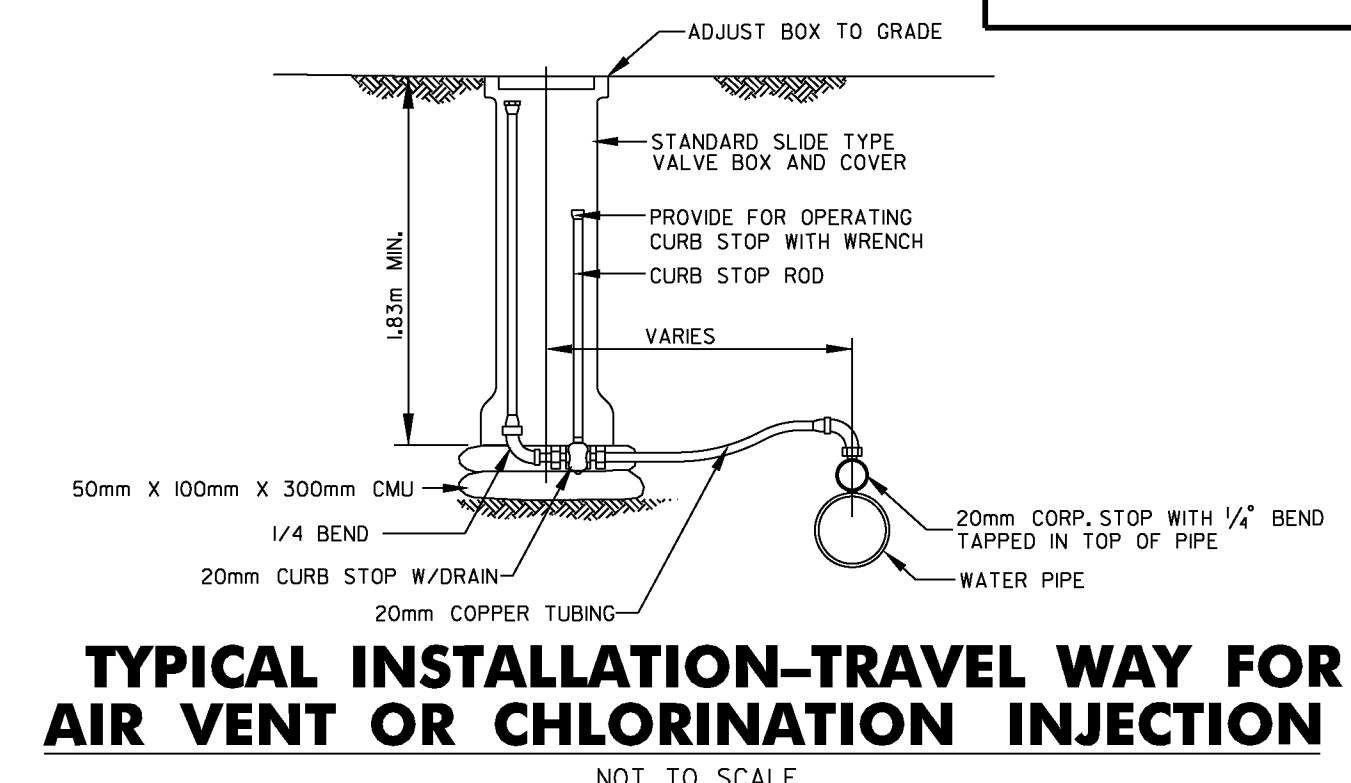
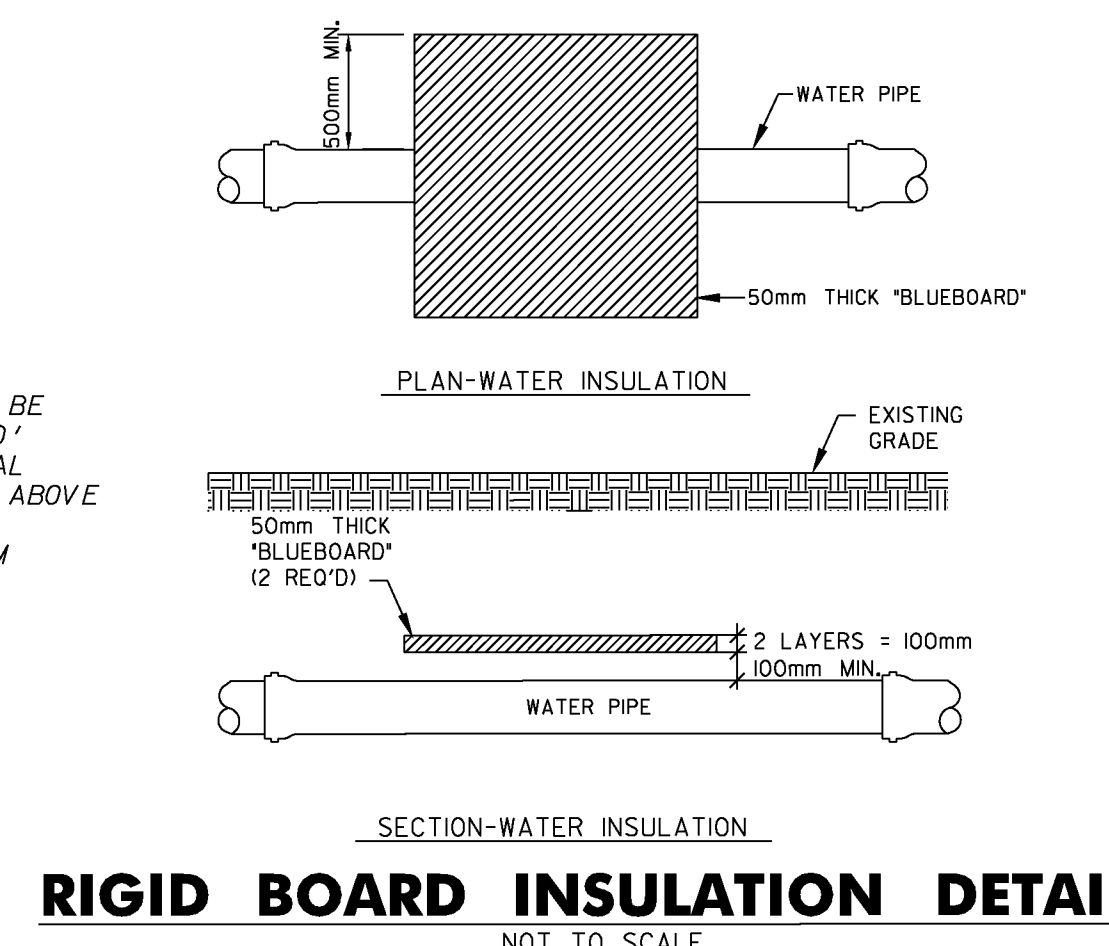
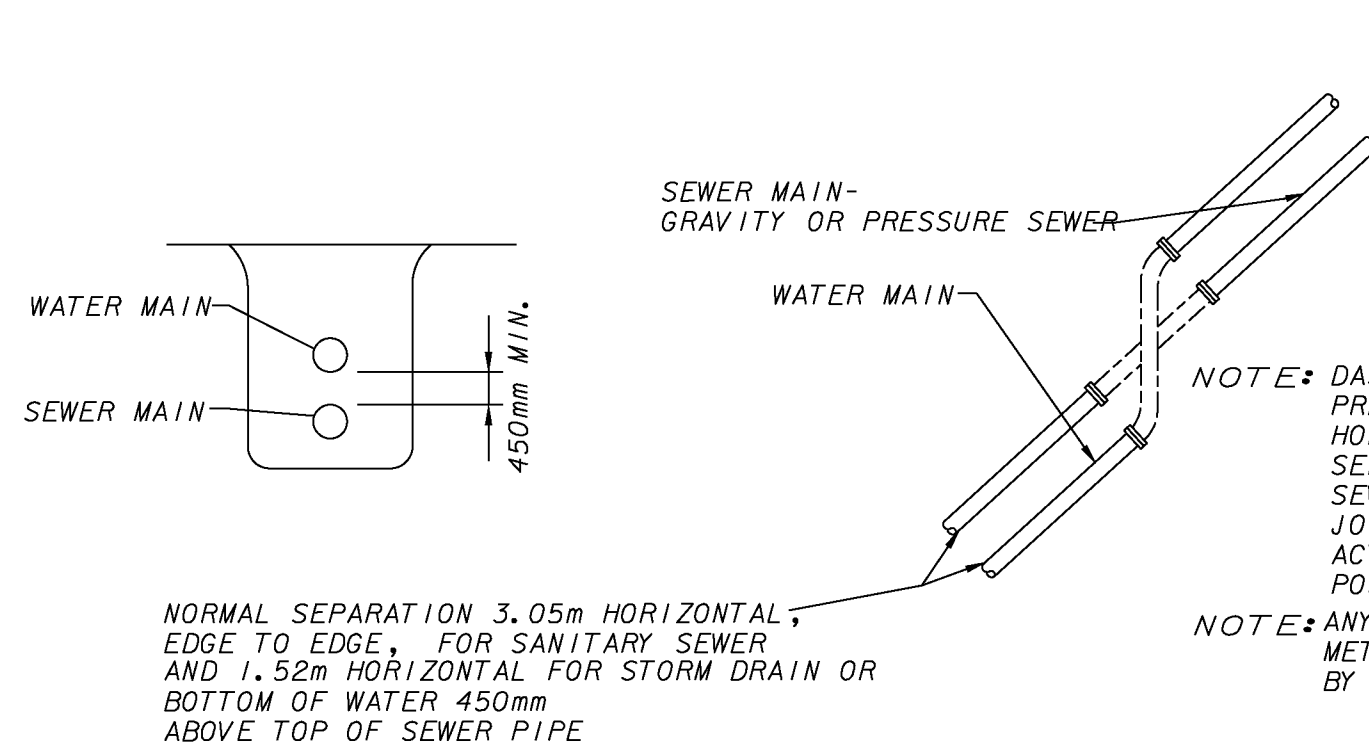

**REPLACEMENT SHEETS**  
ISSUED 10/5/11

PROJECT NAME: DANVILLE  
PROJECT NUMBER: F EGC 028-3(32)  
FILE NAME: ...\\ut\Titles\PlotFiles\FD-13.ppt PLOT DATE: 10/4/2011  
DESIGN SUPERVISOR: TOM NESBITT DRAWN BY: STANTEC  
DESIGNED BY: STANTEC CHECKED BY: STANTEC  
FIRE DISTRICT WATER PLAN FD-13 SHEET 302 OF 306