

Highway Safety Corporation

Glastonbury, CT

Welding Procedure Specification

Material specification A572 gr 50, A709 Gr 50
 Welding process Gas Metal Arc Welding (GMAW) Spray Transfer
 Manual, semi-automatic, or automatic Semi-Automatic
 Position of welding Flat (1F) or Horizontal (2F)
 Filler metal specification AWS A5.18
 Filler metal classification ER70S-6
 Electrode and manufacturer Lincoln Electric Lincoln Weld L-56
 Flux and manufacturer N/A
 Shielding gas 86% Argon / 14% CO2 Flow rate 35-45 CFM
 Single or multiple pass Single or Multiple
 Single or multiple arc Single
 Welding current DCEP
 Polarity Reverse - electrode positive
 Welding progression Stringers
 Root treatment clean base metal
 Preheat and interpass temperature base metal up to 3/4" (50°F) ; over 3/4 thru 1-1/2" (150°F) ; over 1-1/2" thru 2-1/2" (225°F)
 Postheat treatment None
 Electrode extension 3/4" ± 1/4"

WELDING PROCEDURE

Weld size	Pass no.	Electrode size	Welding parameters		Travel speed	Joint detail
			Amperes	Volts		
5/16"	1	0.062"	300 A ± 30	29 V ± 2	15 ipm ± 2	
7/16"	1 & 2	0.062"	↓	↓	15 ipm ± 2	

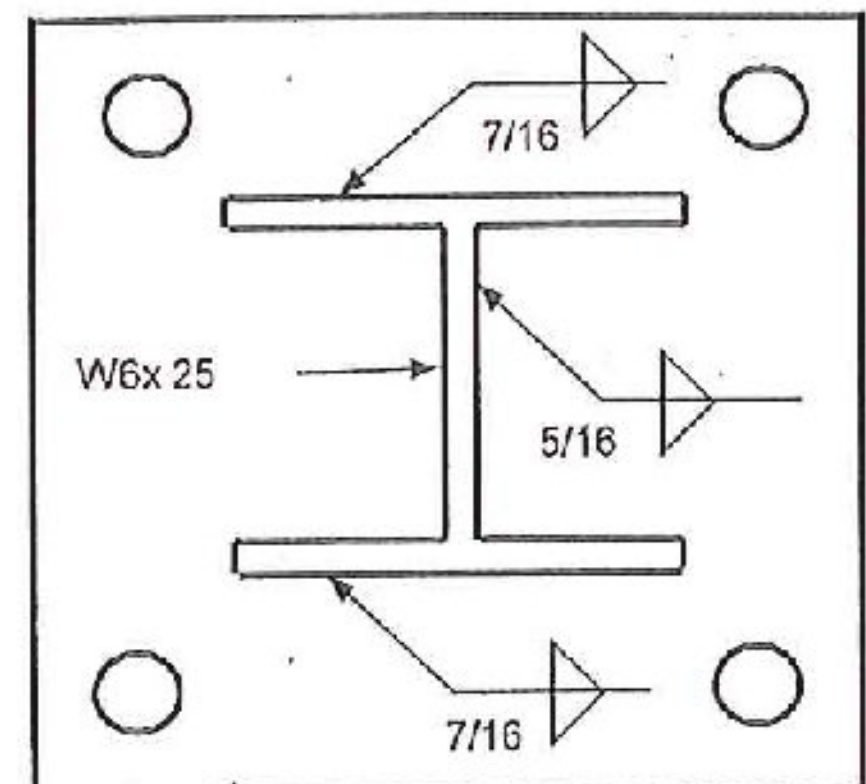

This procedure may vary due to fabrication sequence, fit-up, pass size, etc. within the limitation of variables given in section 5 of latest edition AWS D1.5

WPS no. W-VTPEDPOST1 Fabricator Highway Safety Corporation
 Revision no. 0 Prepared By: Paul Radice
 Supporting PQR no. Pre-Qualified Date 07-14-14
 Project Name STOWE, VT Project Number BRF 029-1 (17)

Paul A. Radice
 CWP 99070221
 QCI Exp. 7/1/2016

