

RURAL

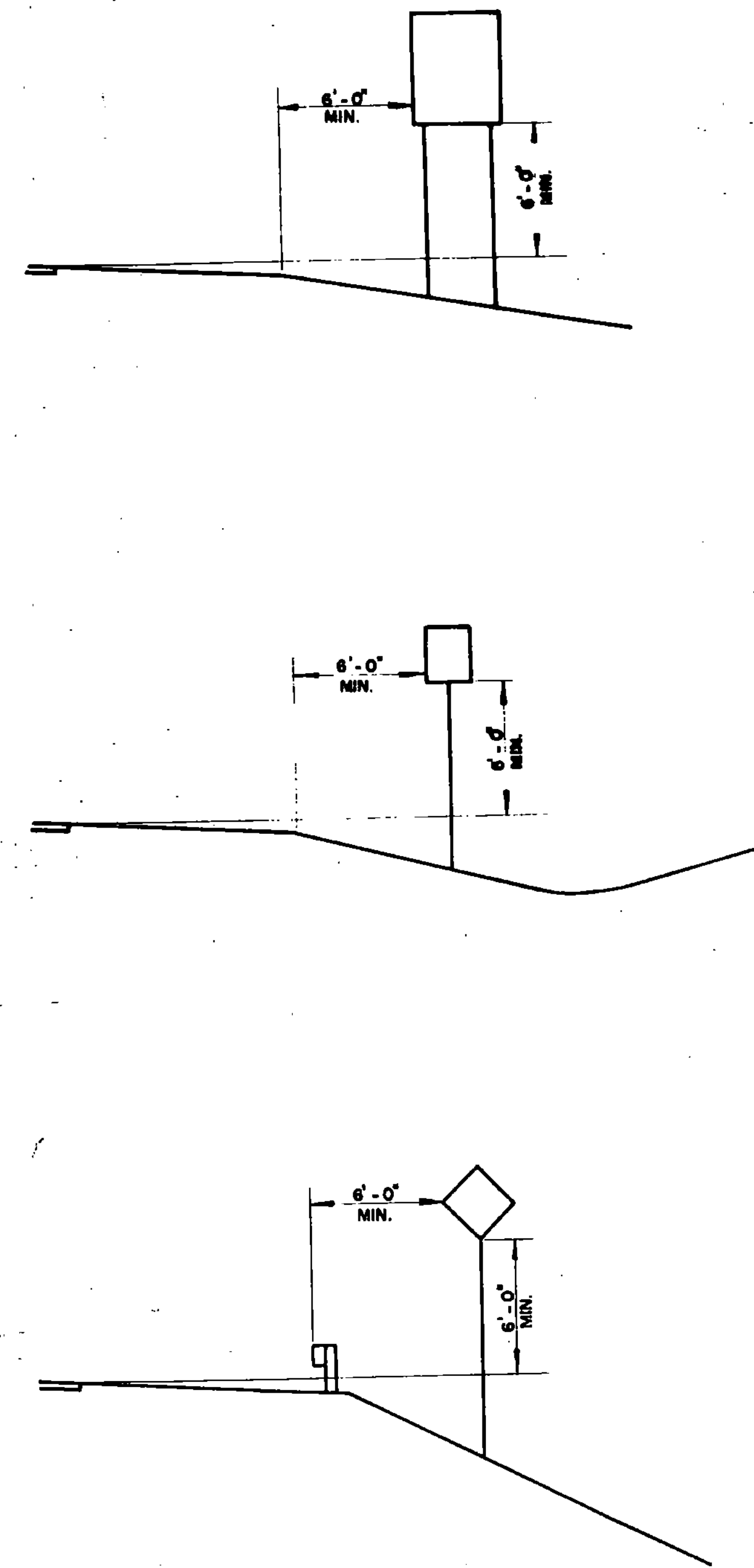

URBAN

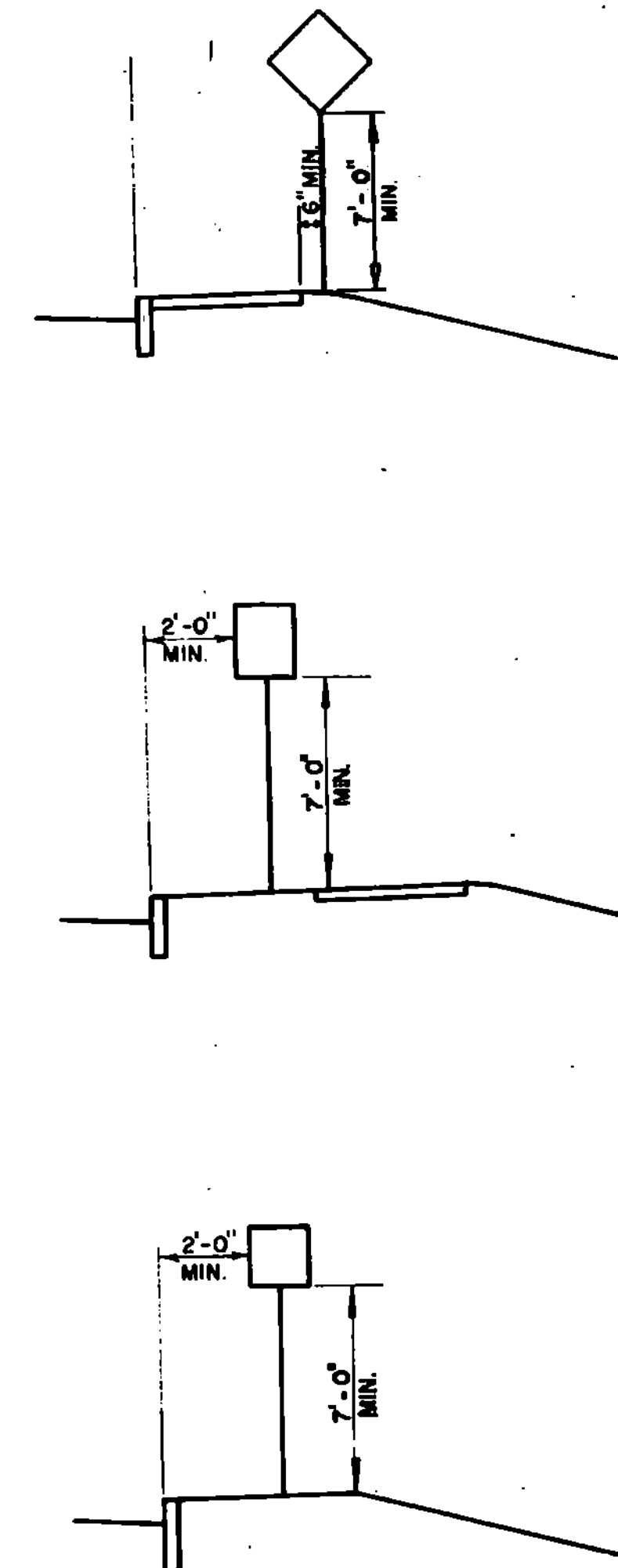

WARNING SIGNS
ON ISLAND IN THE LINE OF TRAFFIC

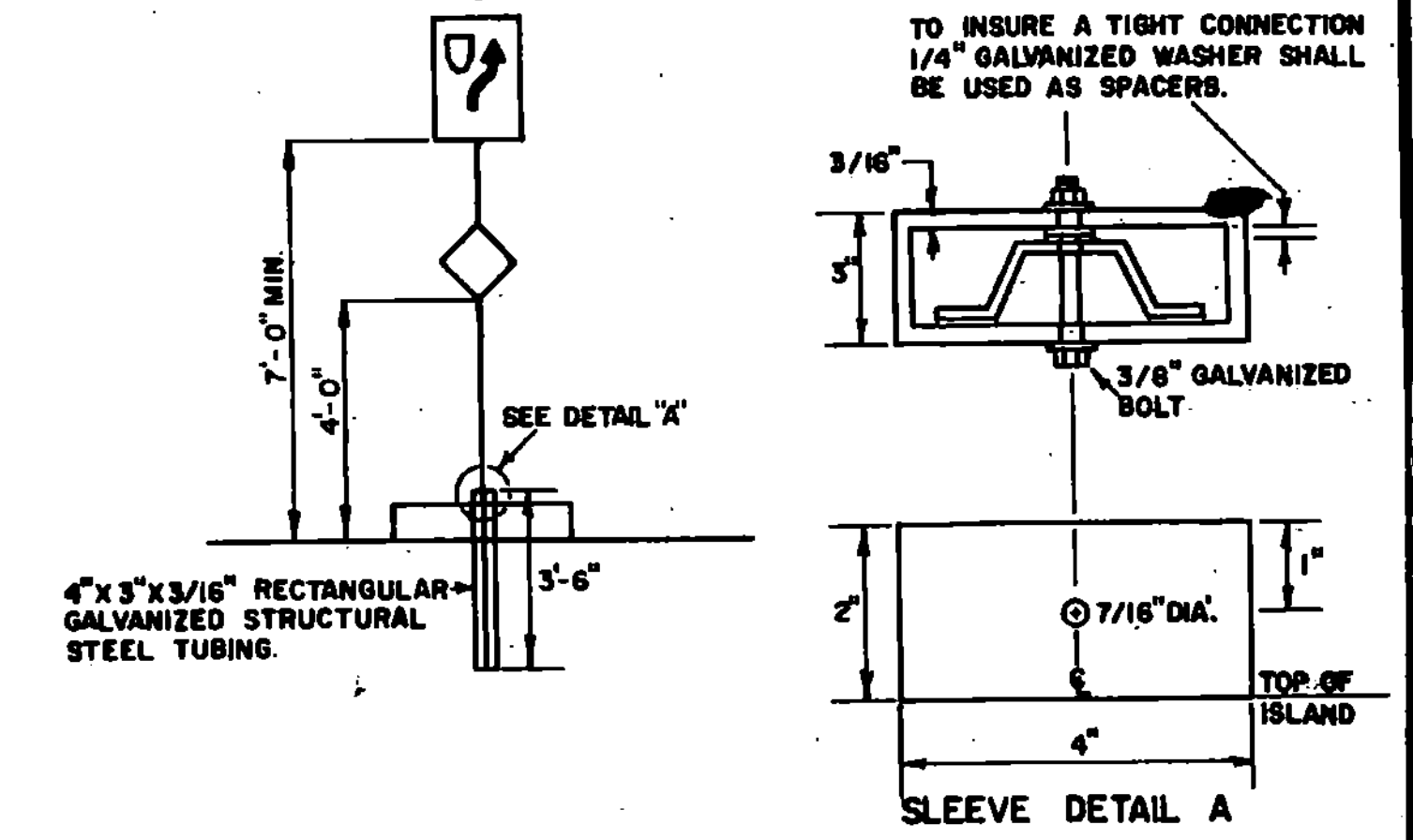

STOP OR YIELD SIGNS
AT WIDE THROAT INTERSECTIONS

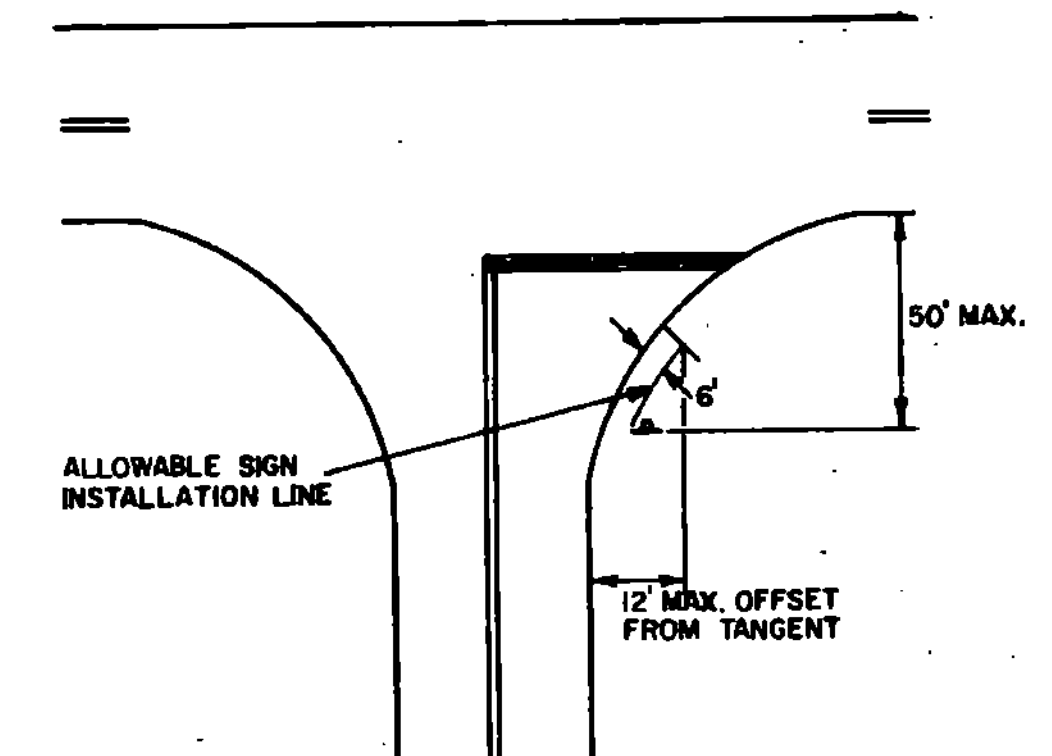

NOTES 1) IN BOTH RURAL AND URBAN LOCATIONS, IF A SECONDARY SIGN IS MOUNTED BELOW ANOTHER SIGN, THE MINIMUM CLEARANCE MAY BE REDUCED BY ONE FOOT.
2) IN RURAL AREAS WITH NO SHOULDER, THE MINIMUM LATERAL CLEARANCE SHOULD BE 12' FROM EDGE OF THE TRAVELED WAY.

REVISIONS AND CORRECTIONS
 JAN. 23, 1978 - DIMENSION FROM SHOULDER TO SIGN CHANGED PER FHWA.
 AUG. 25, 1981 - ADDED STOP AND ISLAND DETAILS, REVISED CURB OFFSET
 FEB. 3, 1988 - UPDATED TO 1986 SPECIFICATIONS

APPROVED
 Dec. 29, 1971

R. W. Arnold
 CHIEF ENGINEER
E. H. Stickney
 ASST. CHIEF ENGINEER
G. M. Lane
 HIGHWAY ENGINEER

STANDARD SIGN PLACEMENT
 CONVENTIONAL ROAD



STANDARD
 E-29