

CAMBER DIAGRAM FOR 1G1 - 7G7

MARK	TL	BL	LE	RE	WL1	WL2	WX1	WX2	SP1	WC1	WC2	LD	C1	C2	C3	C4	C5	C6	C7	C8	C9	PG/LINE	PG/LINE
1G1	121'-1 1/4	121'-0 1/8	1 1/16	1 1/16	41'-1 1/2	79'-10 5/8	41'-7 1/8	80'-3 5/8	8 15/16	13 1/16	7 1/16	12'-1 1/4	3 7/16	6 1/4	8 7/16	9 3/4	10 3/16	9 13/16	8 1/2	6 5/16	3 1/2	2 / L	1 / U
2G2	120'-9 7/16	120'-8 1/4	1 1/16	1 1/8	41'-1 1/2	79'-6 3/4	41'-7 1/8	79'-11 3/4	9 3/16	7 8/16	7 7/16	12'-0 7/8	3 9/16	6 7/16	8 5/8	10	10 3/8	9 15/16	8 5/8	6 3/8	3 1/2	2 / L	1 / W
3G3	120'-5 3/4	120'-4 9/16	1 1/16	1 1/8	41'-1 1/2	79'-3 1/16	41'-7 1/8	79'-8 1/16	9 7/16	7 8/16	7 7/16	12'-0 1/2	3 11/16	6 5/8	8 7/8	10 1/4	10 5/8	10 1/8	8 3/4	6 1/2	3 1/2	2 / L	1 / Y
4G4	120'-2 1/4	120'-1	1 1/16	3 1/16	41'-1 1/2	78'-11 1/2	41'-7 3/16	79'-4 1/2	9 11/16	7 8/16	1 2	12'-0 1/8	3 3/4	6 13/16	9 1/8	10 1/2	10 15/16	10 3/8	8 7/8	6 9/16	3 9/16	2 / L	2 / R
5G5	119'-10 7/8	119'-9 9/16	1 1/16	1 1/4	50'-7 1/2	69'-2 1/16	51'-1 3/16	69'-7 1/4	10 15/16	13 1/16	5 8/16	11'-11 3/4	3 7/8	6 15/16	9 5/16	10 13/16	11 1/4	10 11/16	9 1/8	6 3/4	3 11/16	2 / J	2 / G
6G6	119'-7 11/16	119'-6 5/16	1 1/16	5 1/16	50'-7 1/2	68'-10 13/16	51'-1 3/16	69'-4	11 1/4	7 8/16	5 8/16	11'-11 3/8	3 15/16	7 1/8	9 5/8	11 1/8	11 1/16	11 1/16	9 1/2	7	3 13/16	2 / J	2 / E
7G7	119'-4 9/16	119'-3	1 1/16	1 1/2	50'-7 1/2	68'-7 1/2	51'-1 3/16	69'-0 3/4	11 9/16	7 8/16	5 8/16	11'-11 1/8	4	7 5/16	9 7/8	11 7/16	11 15/16	11 7/16	9 7/8	7 5/16	4 1/16	2 / J	2 / C

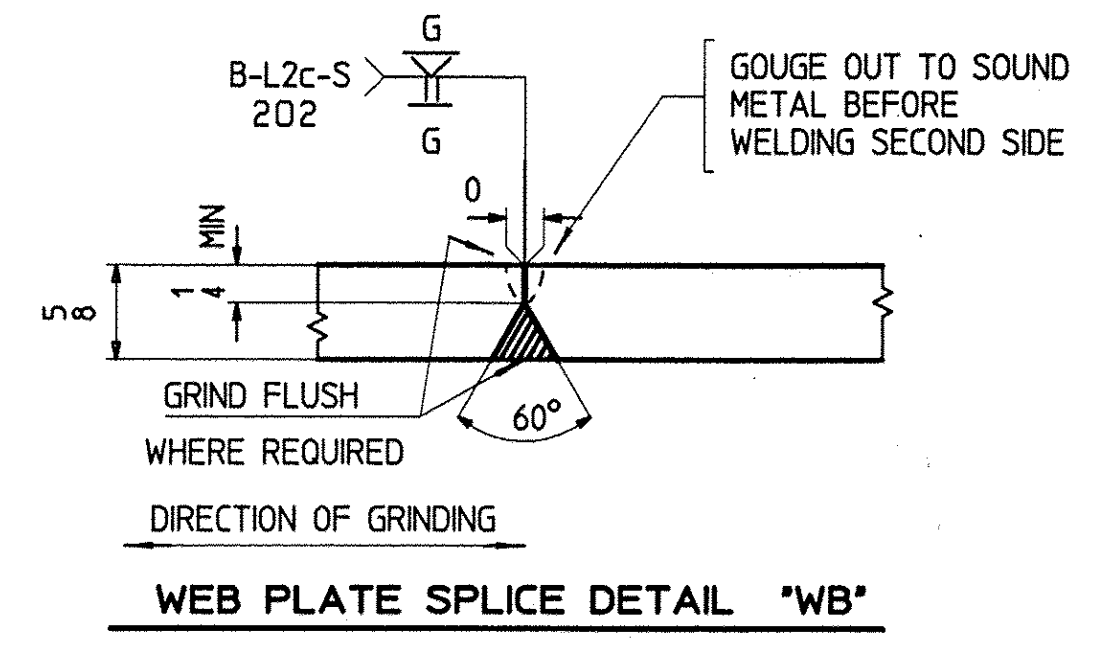

FOR GENERAL NOTES SEE SHEET GNI

REV.	DATE	REMARKS	DWN	CHK	APVL	SHOP
0						
MATERIAL:		SURFACE PREP. & PAINT:		HOLES:		SHOP BOLTS:
M270-GR50WT2		SSPC-SP8/0		N/A		N/A
DESCRIPTION: CAMBER DIAGRAM						
CASCO BAY STEEL STRUCTURES, INC. 75 SPRING HILL ROAD SACO, MAINE 04072 PHONE (207) 282-7360 FAX. (207) 282-1179						
STRUCTURE: VT 103 over Middle Branch Williams Rv. Bridge 9 CHESTER County of Windsor			DRAWN:	DATE:		
			TG	11/18		
			CHKD:	DATE:		
			DO	11/30		
LOCATION: Town of Chester			JOB NO.	DWG NO.		
PROJ NO. BRF 025-1(37)			476	C1		
CUSTOMER: Cold River Bridges				REV.	△	