

**TYPICAL CHANNEL SECTION**  
(NOT TO SCALE)

\* GRUBBING MATERIAL SHALL NOT BE PLACED ON THE STONE FILL IN THE AREA UNDER THE BRIDGE. WHENEVER CHANNEL SLOPE INTERSECTS ROADWAY SUBBASE, GRUBBING MATERIAL SHALL BEGIN AT THE BOTTOM OF SUBBASE.

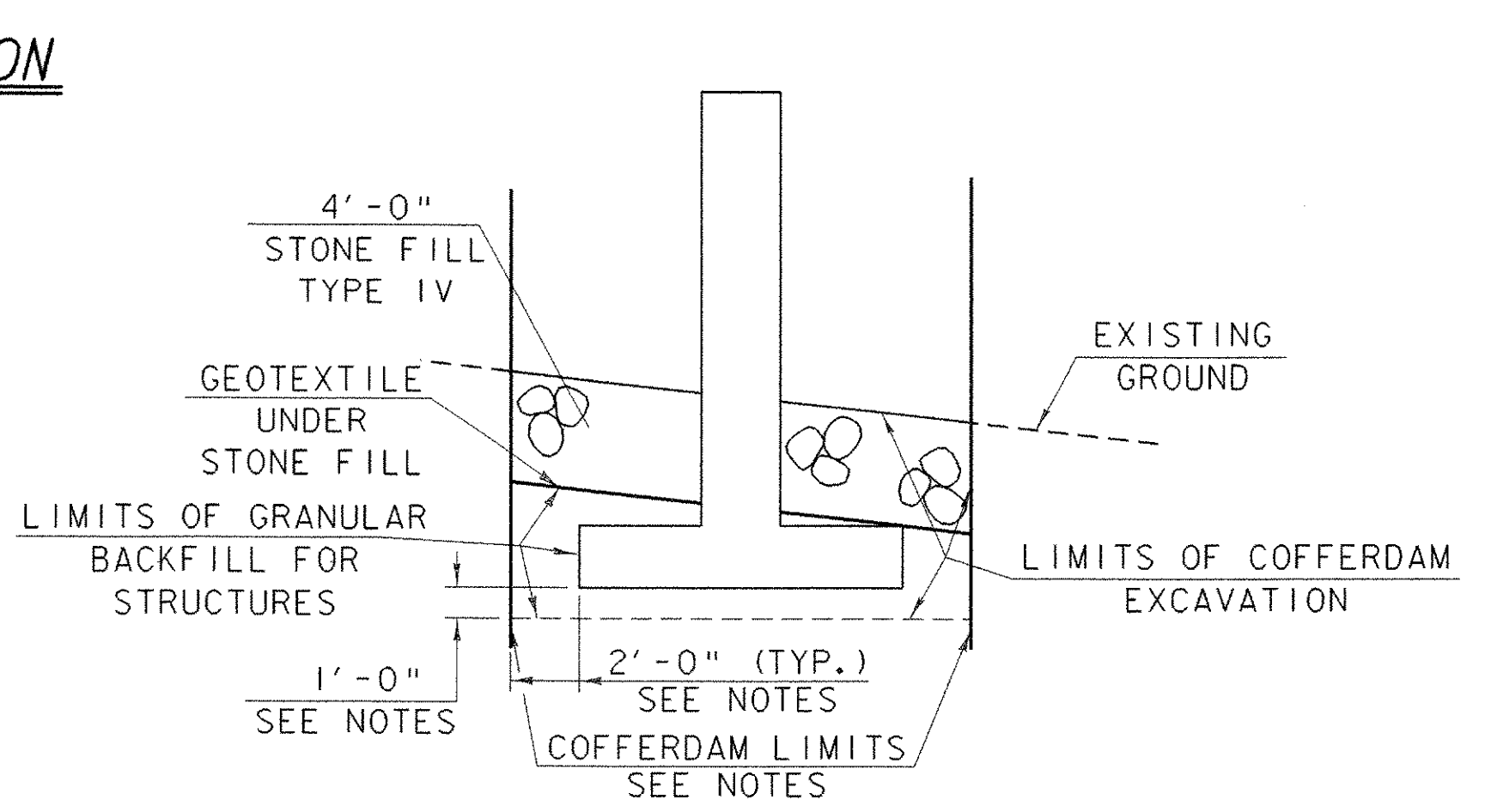

**TYPICAL PIER SECTION**  
NOT TO SCALE

**PIER COFFERDAM NOTES**

- PIER COFFERDAM LIMITS TO BE DETERMINED BY THE CONTRACTOR.
- FOR PURPOSES OF ESTIMATING EARTHWORK QUANTITIES, THE LIMITS OF COFFERDAM AT THE PIERS HAVE BEEN ASSUMED TO BE 2'-0" OUTSIDE THE PERIMETER OF THE FOOTING.
- ONE FOOT UNDERCUT AS DETERMINED NECESSARY BY THE RESIDENT ENGINEER.
- IF A COFFERDAM IS CONSTRUCTED WHICH IS MORE THAN THE INDICATED MINIMUM DISTANCE OUTSIDE THE FOOTING LIMITS, NO PAYMENT WILL BE MADE FOR MATERIAL REMOVED OR MATERIAL PLACED OUTSIDE THE 2'-0" LIMITS.
- FOR PURPOSES OF ESTIMATING EARTHWORK QUANTITIES, THE EXCAVATION WITHIN THE COFFERDAM HAS BEEN ASSUMED TO BE 80 PERCENT ROCK AND 20 PERCENT EARTH. FINAL QUANTITIES WILL BE BASED ON MATERIAL ACTUALLY REMOVED.

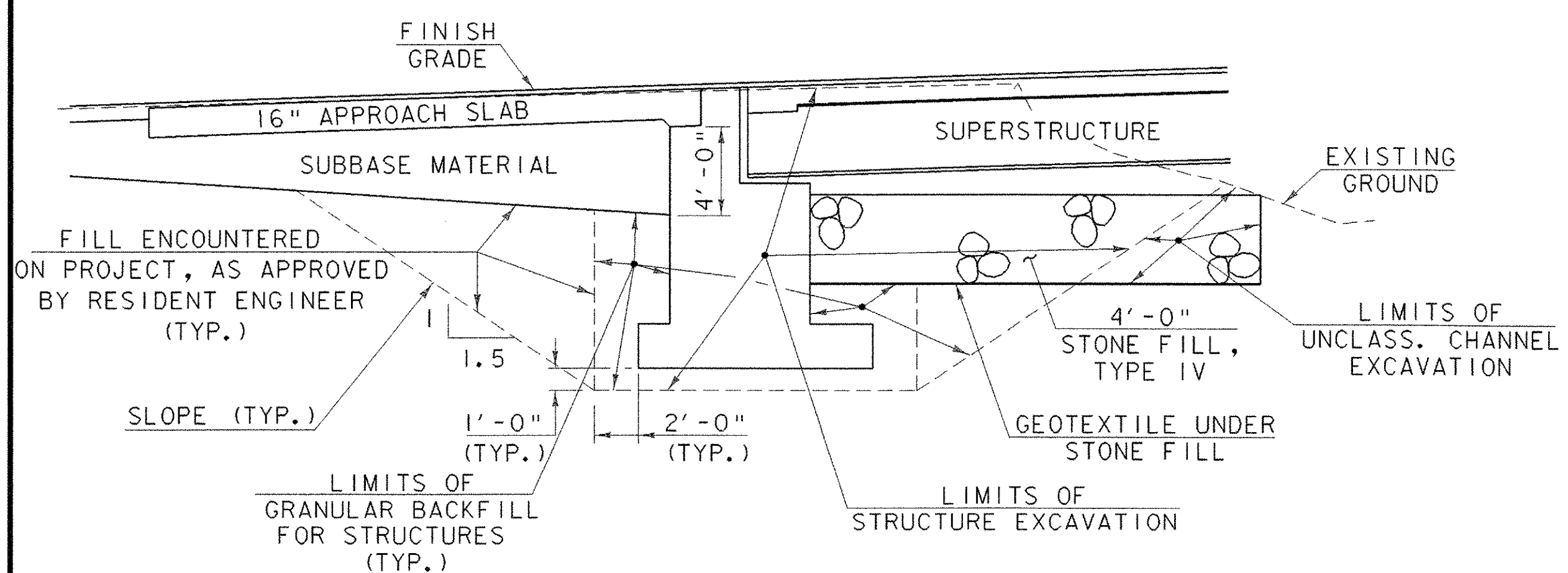

**TYPICAL ABUTMENT SECTION**  
NOT TO SCALE

NOTE: NO PAYMENT WILL BE MADE FOR ANY COFFERDAM AT ABUTMENTS #1 OR #2.

**EXISTING STRUCTURE**

STRUCTURE TYPE	THREE SPAN STEEL BEAM BRIDGE	OVERALL LENGTH	252 FT	INVENTORY RATING	NA
2. SPAN LENGTH(S) CENTER TO CENTER OF BEARINGS	THREE SPANS: 81'-6" - 81'-11" - 81'-6"				
3. CLEAR SPAN LENGTH(S) NORMAL TO STREAM	THREE SPANS @ 55 FT = 165 FT				
4. WATERWAY AREA OF FULL OPENING (NORMAL TO STREAM)	2000 SQ FT	VERTICAL CLEARANCE ABOVE STREAMBED	11 FT		
5. WATER SURFACE ELEVATION @ 0.233	1132.4	WATER SURFACE ELEVATION @ 0.50	1134.5		
6. WATER SURFACE ELEVATION AT FLOOD OF RECORD	NA	YEAR	NA	ESTIMATED DISCHARGE	NA
7. DOES ALL WATER PASS THROUGH EXISTING STRUCTURE? YES/IF NOT, AT WHAT FREQUENCY AND ELEVATION DOES RELIEF OCCUR?	N/A				
8. TYPE OF SUBSTRUCTURE FOUNDATION MATERIAL	REMOVE				
9. DISPOSITION OF STRUCTURE	REMOVE				

**NEW STRUCTURE**

STRUCTURE GEOMETRY:	NEW THREE SPAN CONTINUOUS PLATE GIRDER BRIDGE	OVERALL LENGTH	279.08 FT		
1. STRUCTURE TYPE	SPAN ONE: 79'-0" SPAN TWO: 114'-0" SPAN THREE: 79'-0"				
2. SPAN LENGTH(S) CENTER TO CENTER OF BEARINGS	10 FT				
3. VERTICAL CLEARANCE ABOVE STREAMBED OR ROAD UNDER	3 SPANS, 53' + 77' + 53' = 183' TOTAL				
4. CLEAR SPAN LENGTH(S) NORMAL TO STREAM	2200 SQ FT				
5. WATERWAY AREA OF FULL OPENING (NORMAL TO STREAM)	YES				
6. ARE PROVISIONS TO BE MADE FOR PUBLIC UTILITIES?					
HYDRAULIC DATA:					
1. Q 2.33	2400 CFS	WATER ELEVATION	1132.4 VELOCITY	10.4 FPS	
0 10	4000 CFS	WATER ELEVATION	1133.7 VELOCITY	10.6 FPS	
0 25	5000 CFS	WATER ELEVATION	1134.1 VELOCITY	11.4 FPS	
0 50	6000 CFS	WATER ELEVATION	1134.5 VELOCITY	12.1 FPS	
0 100	7000 CFS	WATER ELEVATION	1134.9 VELOCITY	12.7 FPS	
2. DRAINAGE AREA	37.7 SQ MI	CHARACTER OF TERRAIN	HILLY TO MOUNTAINOUS, MOSTLY FORESTED		
3. ARE THERE OBJECTIONS TO A PIER IN THE STREAM?	NO				
4. DOES STREAM REACH ITS MAXIMUM HIGH WATER ELEVATION RAPIDLY?	YES IS ORDINARY RISE RAPID? YES				
5. NATURE OF NATURAL STREAMBED	WELL ARMORED WITH MEDIUM TO LARGE COBBLES AND BOULDERS				
6. ESTIMATED SCOUR DEPTH	1 FT	COMMENT ON: DRIFT	MODERATE ICE SLIGHT		
7. WILL ALL WATER PASS THROUGH NEW STRUCTURE? YES/IF NOT, WHAT FREQUENCY AND ELEVATION WILL RELIEF OCCUR?	N/A				
8. VERTICAL CLEARANCE ABOVE Q 100	4.2 FT				
9. ALLOWABLE WATER SURFACE ELEVATION	1139.1	LIMITED BY	MINIMUM BOTTOM OF LOW GIRDER ELEVATION		
10. IS DESIGN STAGE AFFECTED BY UPSTREAM OR DOWNSTREAM CONDITIONS?	NO IF YES, DESCRIBE				
11. ORDINARY LOW WATER	40 CFS	DEPTH	0.5 FT	ORDINARY HIGH WATER	1150 CFS
12. AVERAGE DAILY FLOW	80 CFS	STREAMBANK OR CHANNEL PROTECTION REQUIRED	STONE FILL, TYPE IV, RETAIN AS MUCH EXISTING STONE FILL AS POSSIBLE		
13. DISTANCE TO EXISTING UPSTREAM STRUCTURE	NA	SPAN	NA	WATERWAY AREA OF FULL OPENING	NA
14. DISTANCE TO EXISTING DOWNSTREAM STRUCTURE	1.7 MI	SPAN	209 FT	WATERWAY AREA OF FULL OPENING	NA

ALLOWABLE STRESSES:						
1. DESIGN LIVE LOAD AASHTO	HS-25-44					
2. ALLOWABLE LOAD FOR SPREAD FOOTINGS ON SOIL	SEE SHEET 49 NOTE # 8 ON LEDGE NA					
3. ALLOWABLE LOAD FOR PILING	N/A	TYPE	N/A	ESTIMATED LENGTH	N/A	
4. ALLOWABLE STRESS FOR STRUCTURAL STEEL AASHTO	M270 G50W	TENSION	27000 PSI			
5. ALLOWABLE STRESS FOR REINFORCING STEEL GRADE 60	TENSION		24000 PSI	COMPRESSION	20000 PSI	
6. ALLOWABLE STRESS FOR CONCRETE CLASS A (HPC - A)	f <sub>c</sub>	4000 PSI	f <sub>c</sub>	1600 PSI		
	CLASS B (HPC - B)	f <sub>c</sub>	3500 PSI	f <sub>c</sub>	1400 PSI	
TRAFFIC MAINTENANCE:						
1. IS TRAFFIC TO BE MAINTAINED? YES/IF YES, ON EXISTING STRUCTURE/NO OR ON TEMPORARY BRIDGE/YES	YES IF YES, DESCRIBE					
2. TEMPORARY BRIDGE REQUIREMENTS: ONE OR TWO WAY/TWO WAY	TRAFFIC CONTROL SIGNALS REQUIRED NA					
	MINIMUM CLEAR SPAN	200 FT	MINIMUM CLEAR HEIGHT	8 FT	MINIMUM WATERWAY AREA	800 SQ FT
	ARE SIDEWALKS REQUIRED?	NO	IF SO, ON WHAT SIDE?	N/A		

**MINIMUM TEMPORARY BRIDGE REQUIREMENTS**  
(NOT TO SCALE)

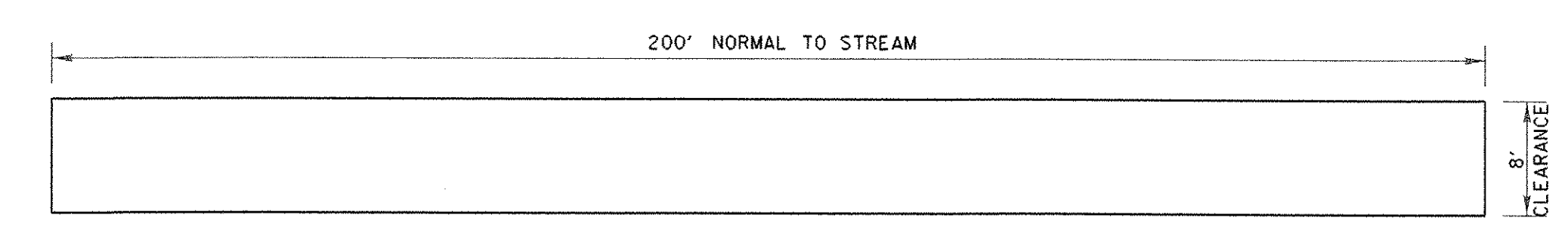

NOTE: ONE PIER IN THE CHANNEL IS ACCEPTABLE. PIER MUST BE A MAX WIDTH OF 4' AND PROPERLY ALIGNED WITH THE CHANNEL.

LOAD RATING (TONS)							
STRESS LEVELS	TRUCK						
	H	HS	3S2	6 AXLE	3A. STR.	4A. STR.	5A. SEMI
INVENTORY	46	52	85	67	69	79	
0.55 Fy <sub>s</sub>	52	73	85	67	69	79	
0.67 Fy <sub>s</sub>							
OPERATING	87	101	116				
0.75 Fy <sub>s</sub>							

**STATE OF VERMONT AGENCY OF TRANSPORTATION**

Town of **WOODFORD** Bridge No. **11**  
Highway No. **VT. 9** Log Sta. **11**  
Surv. Sta. **11**

**VT. 9 OVER ROARING BRANCH OF WALLOOMSAC RIVER PRELIMINARY INFORMATION**

Designed By **M. EVANS-MONGEON** Drawn By **M. EVANS-MONGEON**  
Checked By **Date** Bridge Design Supervisor **Date**  
PROJECT **WOODFORD** PROJECT NO. **BHF 010-(29)**  
I.G.C. Info. **/B4e039/structures/se039pl.dgn** se039plJ  
Bridge Sheet No. **3** of **106**