

SINGLE SUPPORT

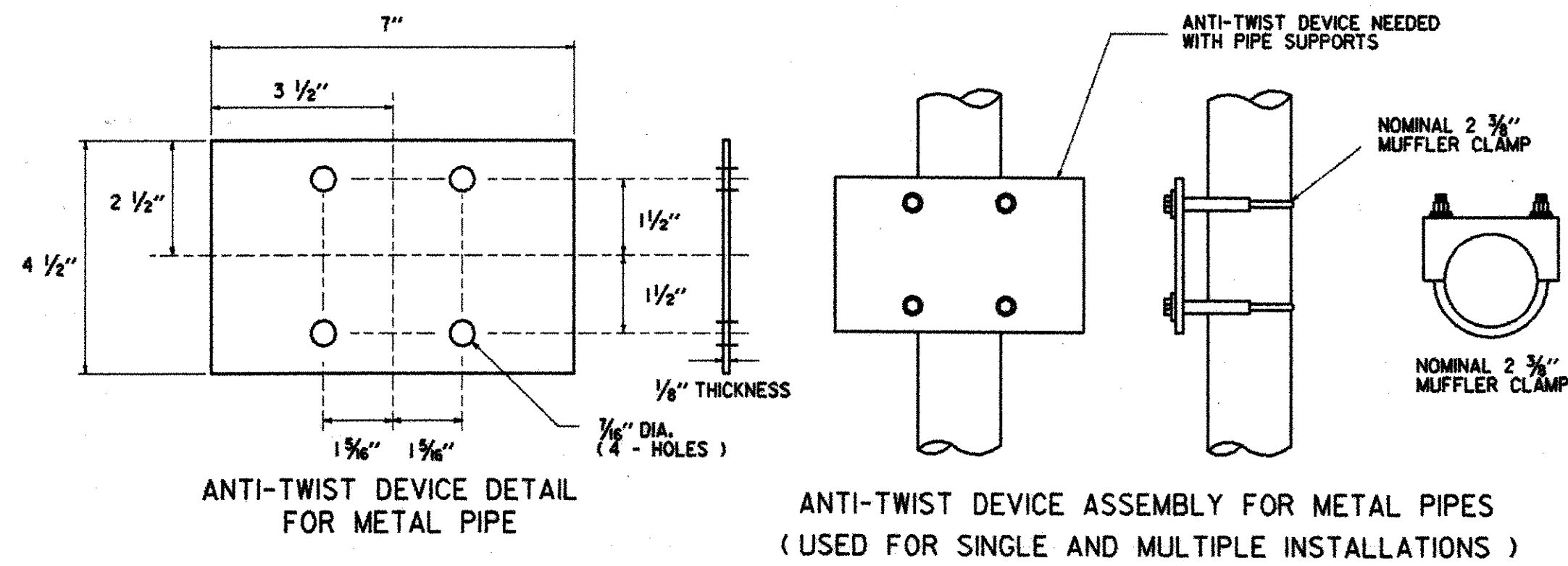

ANTI-TWIST DEVICE DETAIL FOR METAL PIPE

ANTI-TWIST DEVICE ASSEMBLY FOR METAL PIPES (USED FOR SINGLE AND MULTIPLE INSTALLATIONS)

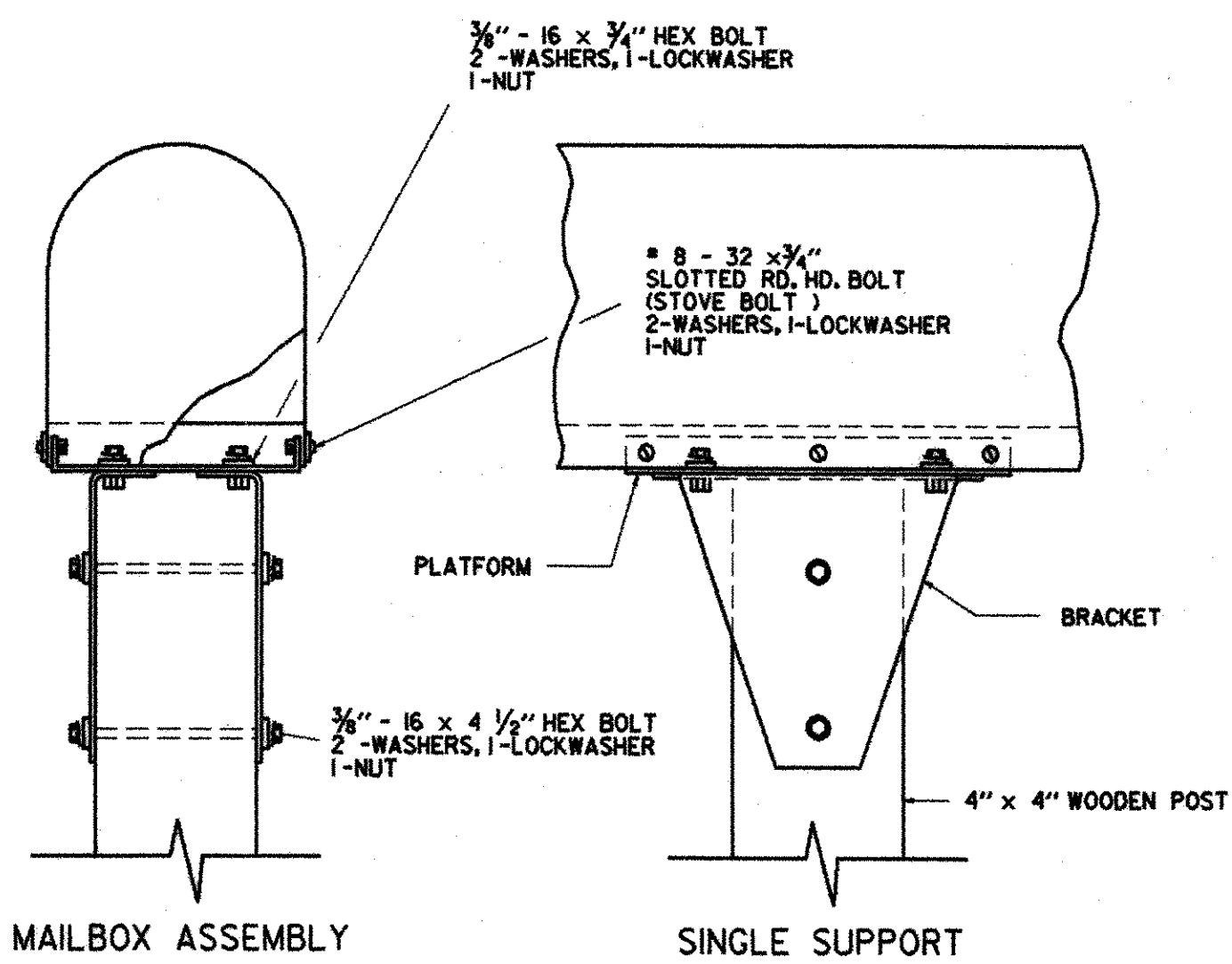

MAILBOX ASSEMBLY

SINGLE SUPPORT

NOTES

1. ONLY LIGHTWEIGHT MAILBOXES MADE OF LIGHT SHEET METAL OR PLASTIC SHALL BE USED. MAILBOXES SHALL MEET REQUIREMENTS AND APPROVAL OF THE U.S. POSTAL SERVICE.
2. AN ALTERNATE MAILBOX SUPPORT STRUCTURE DESIGN AND CONSTRUCTION MAY BE USED AS LONG AS PROVEN CRASHWORTHY AND MEETS GUIDELINES AS SET OUT IN AASHTO'S "GUIDE FOR ERECTING MAILBOXES ON HIGHWAYS". SUPPORT STRUCTURE SHALL ALSO MEET REQUIREMENTS OF THE U.S. POSTAL SERVICE.
3. MAILBOX TURNOUT SHALL MEET B-17 STANDARD AS SET OUT IN "STATE OF VERMONT DEPT. OF HIGHWAYS DESIGN STANDARDS FOR ROAD AND BRIDGE CONSTRUCTION".
4. IF THE STANDARD TURNOUT OFFSET CANNOT BE ATTAINED DUE TO RIGHT-OF-WAY CONSTRAINTS OR OTHER REASONS THE TURNOUT SHALL BE MODIFIED AS DIRECTED BY THE ENGINEER.

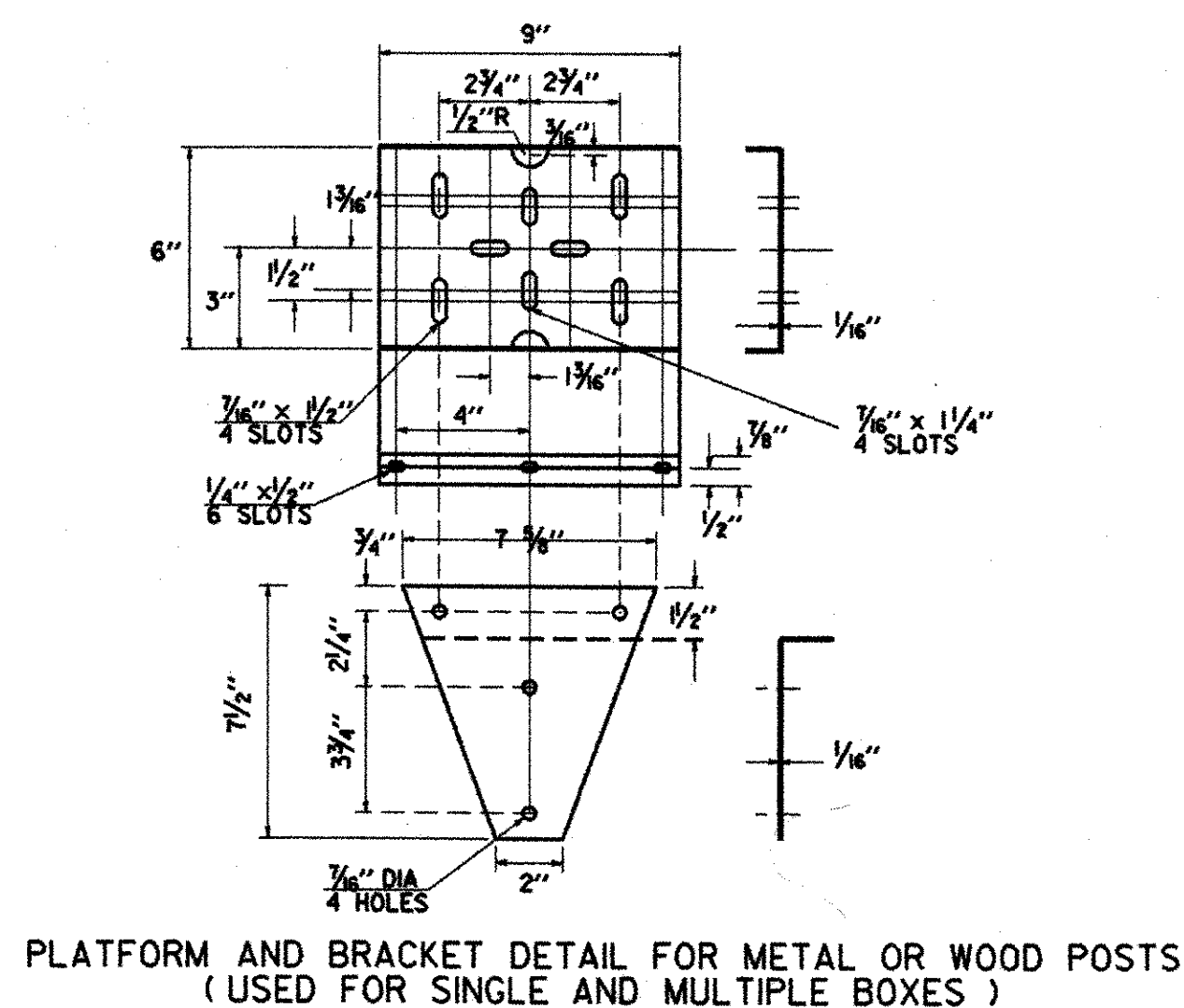
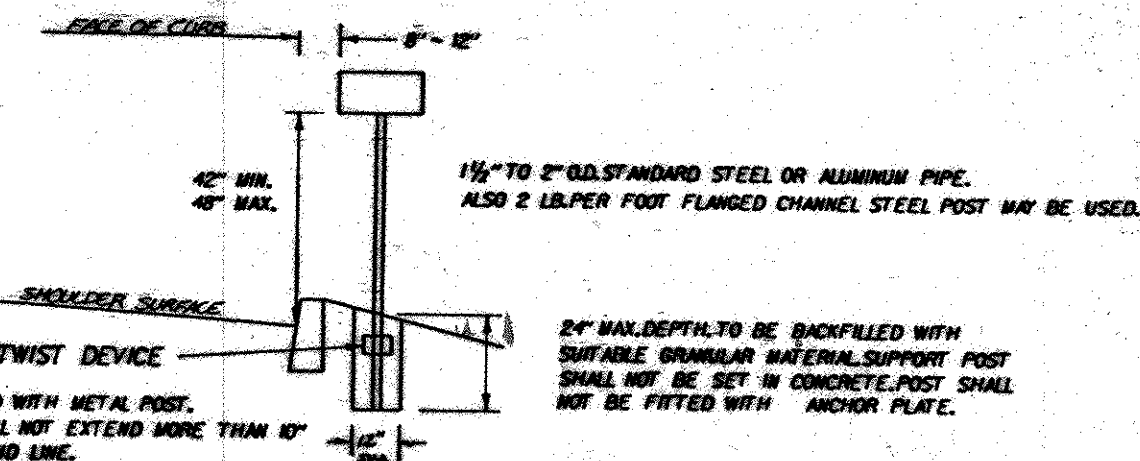
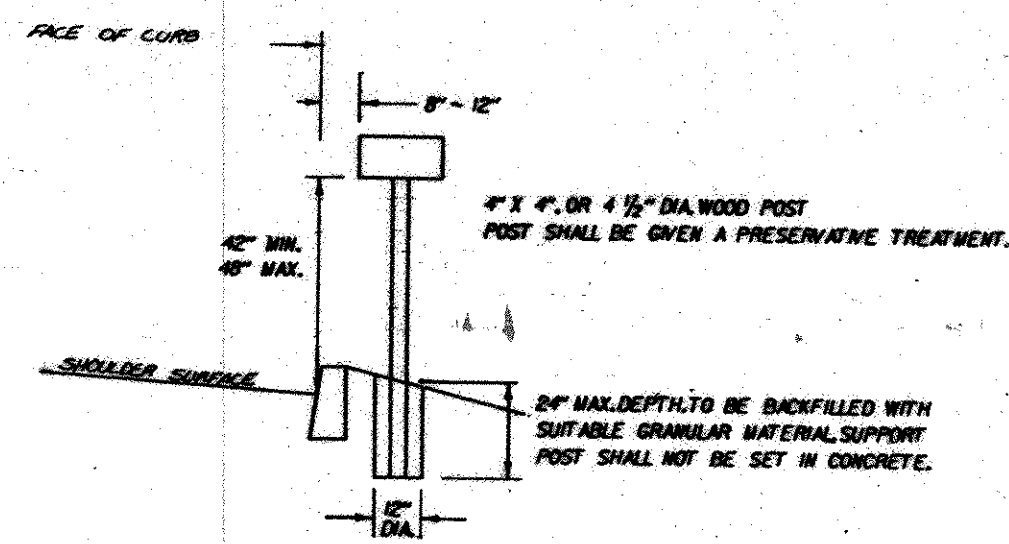

PLATFORM AND BRACKET DETAIL FOR METAL OR WOOD POSTS (USED FOR SINGLE AND MULTIPLE BOXES)

MULTIPLE BOX INSTALLATION

TYPICAL INSTALLATION SPECIFICATIONS

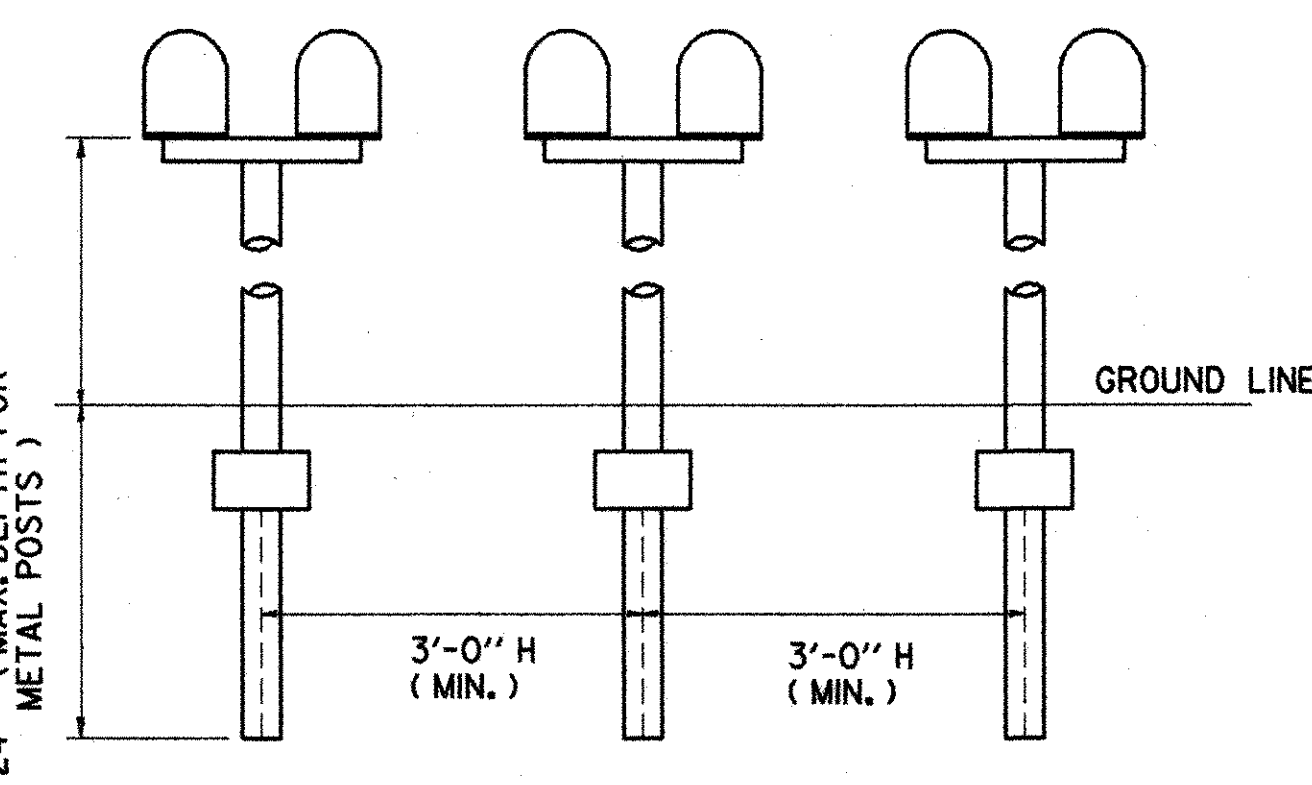
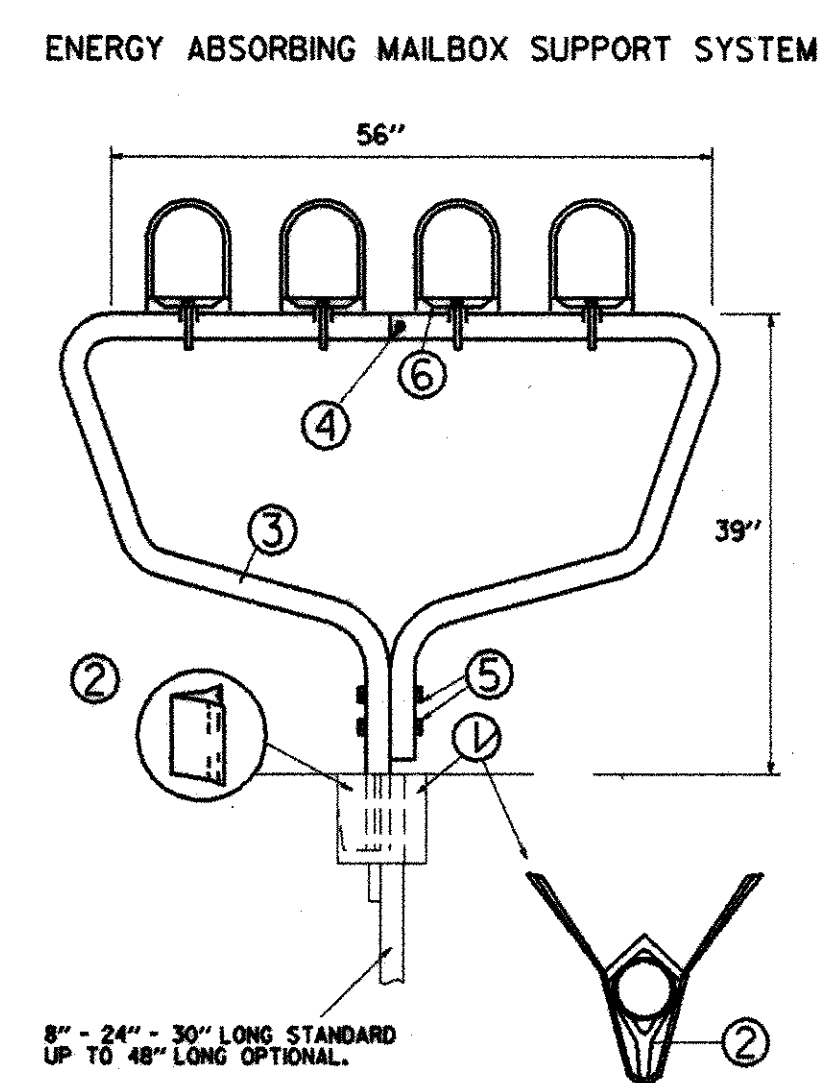

SPACING FOR MULTIPLE POST INSTALLATION

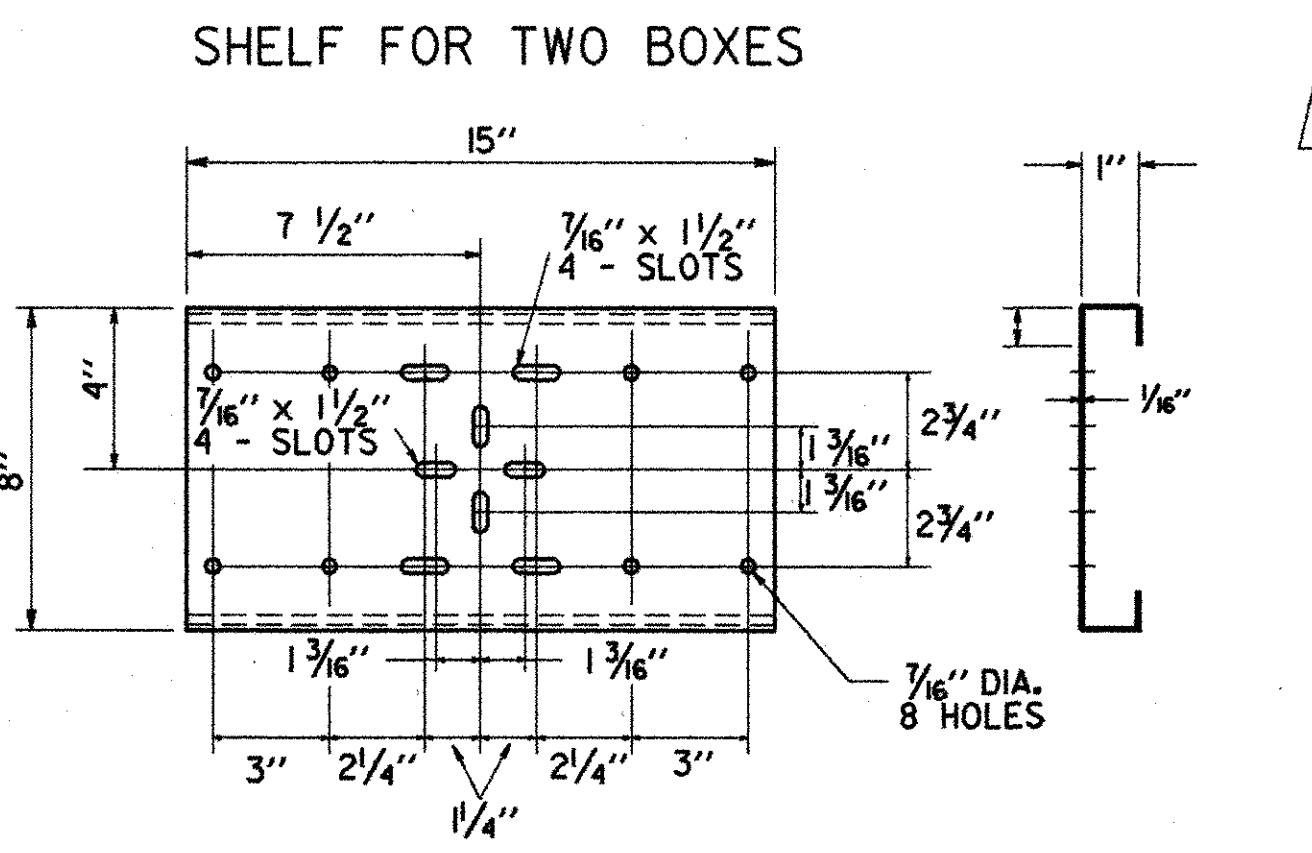

SHelf FOR TWO BOXES

- 1 V-LOC SOCKET:
STABILIZER FIN IS 12 GAUGE HOT ROLLED CARBON SHEET STEEL, COMMERCIAL QUALITY. THE FIN IS FORMED FROM SHEET STEEL TO THE SHOWN CONFIGURATION.
LEG ANGLE IS 3/4" x 2" x 2" ANGLE HR 1020 COMMERCIAL QUALITY, 1/4" TH. ANGLE AVAILABLE.
WELDS ARE FOUR 1/4" x 1 1/2" FILLETS MINIMUM.
FINISH IS DIP-COATED WITH RUST INHIBITING PRIMER, FED. SPEC. TTP636. GALVANIZING AVAILABLE.
- 2 V-LOC WEDGE:
THE V-LOC WEDGE IS STEEL TUBING MADE TO ASTM A-500, GRADE B SPECIFICATIONS, THEN PRESSED FORMED INTO WEDGE FORM.
- 3 TUBING:
THE POST IS WELDED MECHANICAL TUBING PRODUCED TO ASTM GRADE 4500, GRADE B, 2" O.D. x 0.65 WALL THICKNESS, GALVANIZED, FORMED AND PUNCHED, ASSEMBLED BEFORE SHIPMENT.
- 4 BRACKET:
1 3/8" x 2 1/2" HEX HEAD BOLT ZINC PLATED
1 3/8" NYLON INSERT HEX LOCK NUT ZINC PLATED
2 3/8" FLAT WASHERS ZINC PLATED
- 5 2 5/8" x 4 1/2" HEX BOLTS ZINC PLATED
2 3/8" NYLON INSERT HEX LOCK NUTS ZINC PLATED
4 3/8" FLAT WASHERS ZINC PLATED

ENERGY ABSORBING MAILBOX SUPPORT SYSTEM

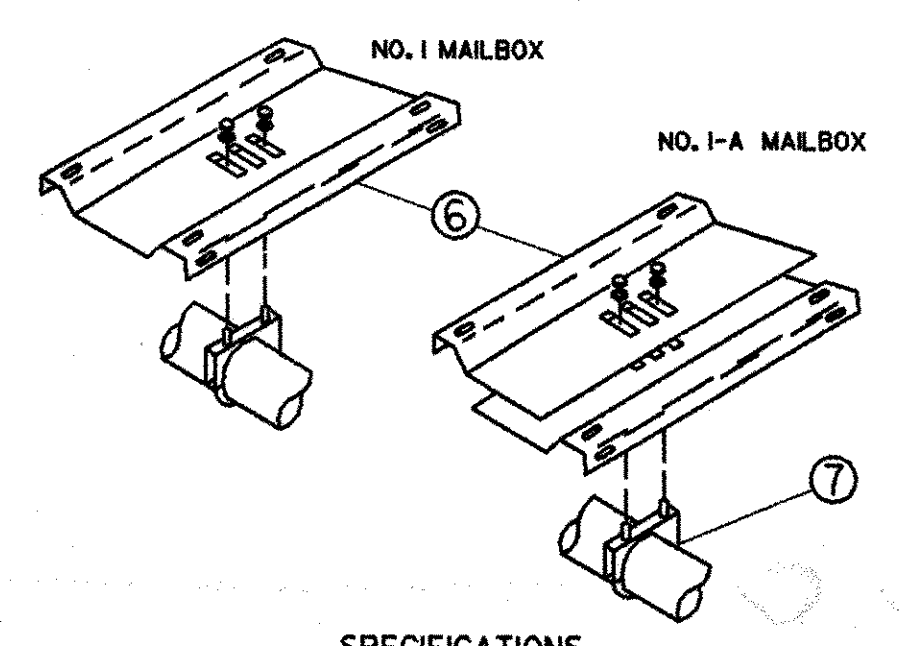

SPECIFICATIONS

- 6 BRACKETS:
PRE-GALVANIZED 20 GAUGE SHEET STEEL PUNCHED AND FORMED TO SHOWN SHAPE. ADJUSTABLE TO FIT STANDARD RURAL MAILBOXES NO. 1, 1B x 8 1/2" x 8 1/2" NO. 1-A, 21 x 8 x 10 1/2."
- 7 U-CLAMP WITH SADDLE 3/8" x 1 1/4", 2 3/8" HEX NUTS ZINC PLATED, 2 3/8" FLAT WASHERS ZINC PLATED.

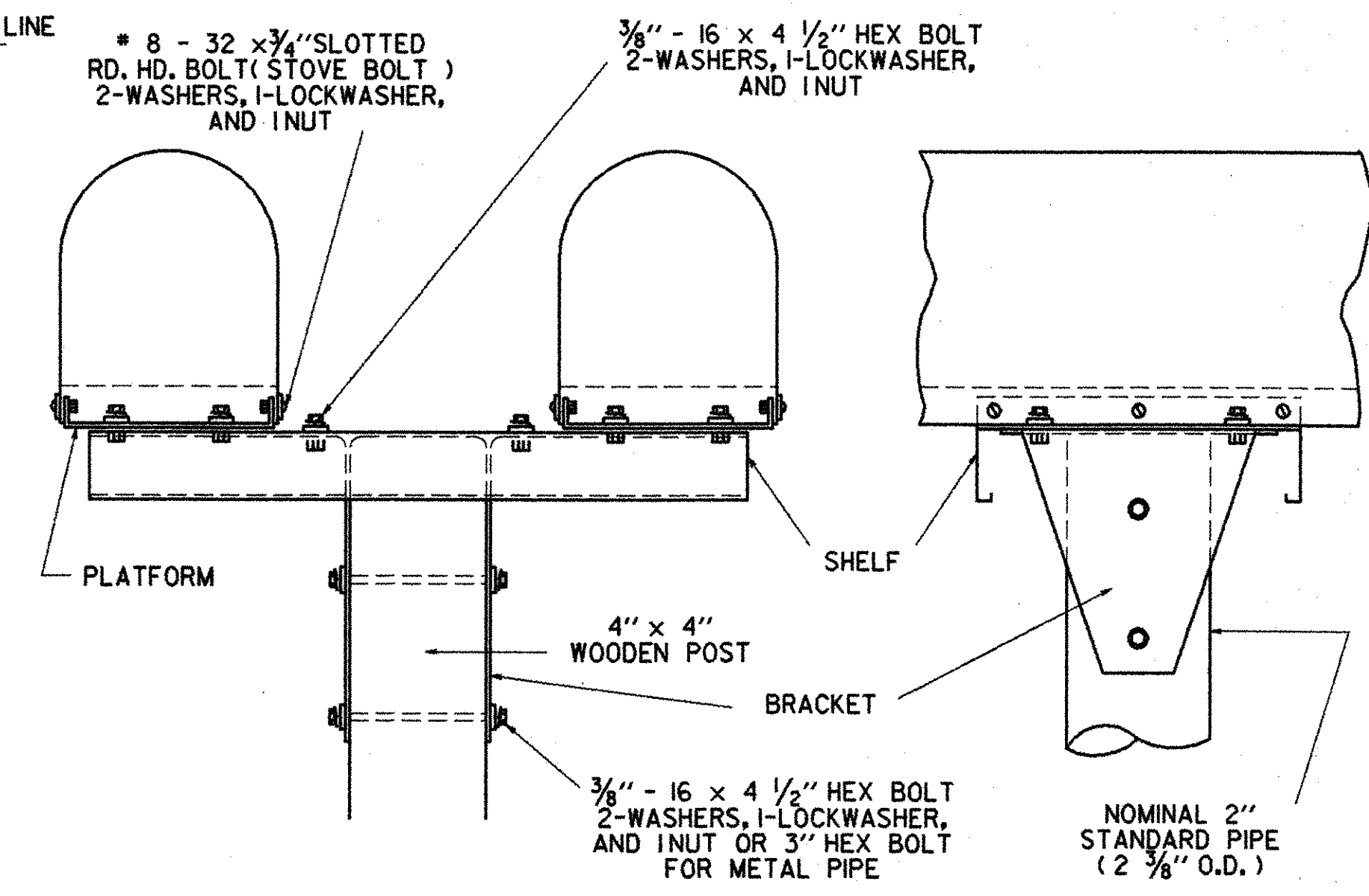

PLATFORM

SHELF

4" x 4" WOODEN POST

BRACKET

3/8" - 16 x 4 1/2" HEX BOLT 2-WASHERS, 1-LOCKWASHER, AND 1NUT OR 3" HEX BOLT FOR METAL PIPE

NOMINAL 2" STANDARD PIPE (2 5/8" O.D.)

MAILBOX SUPPORT DETAIL

DATE PLOTTED 1-10-89

DRAWN BY DAYE DATE 1-89

SQUAD LEADER _____

DESIGN FILE NO. _____

PROJ. NAME ADDISON

PROJ. NO. HES 017-1(4)S

SHEET 18 OF 47 SHEETS