

SECTION A - A

SCALE: 3" = 1'-0"
(REFER TO SHEET 46 FOR LOCATION)

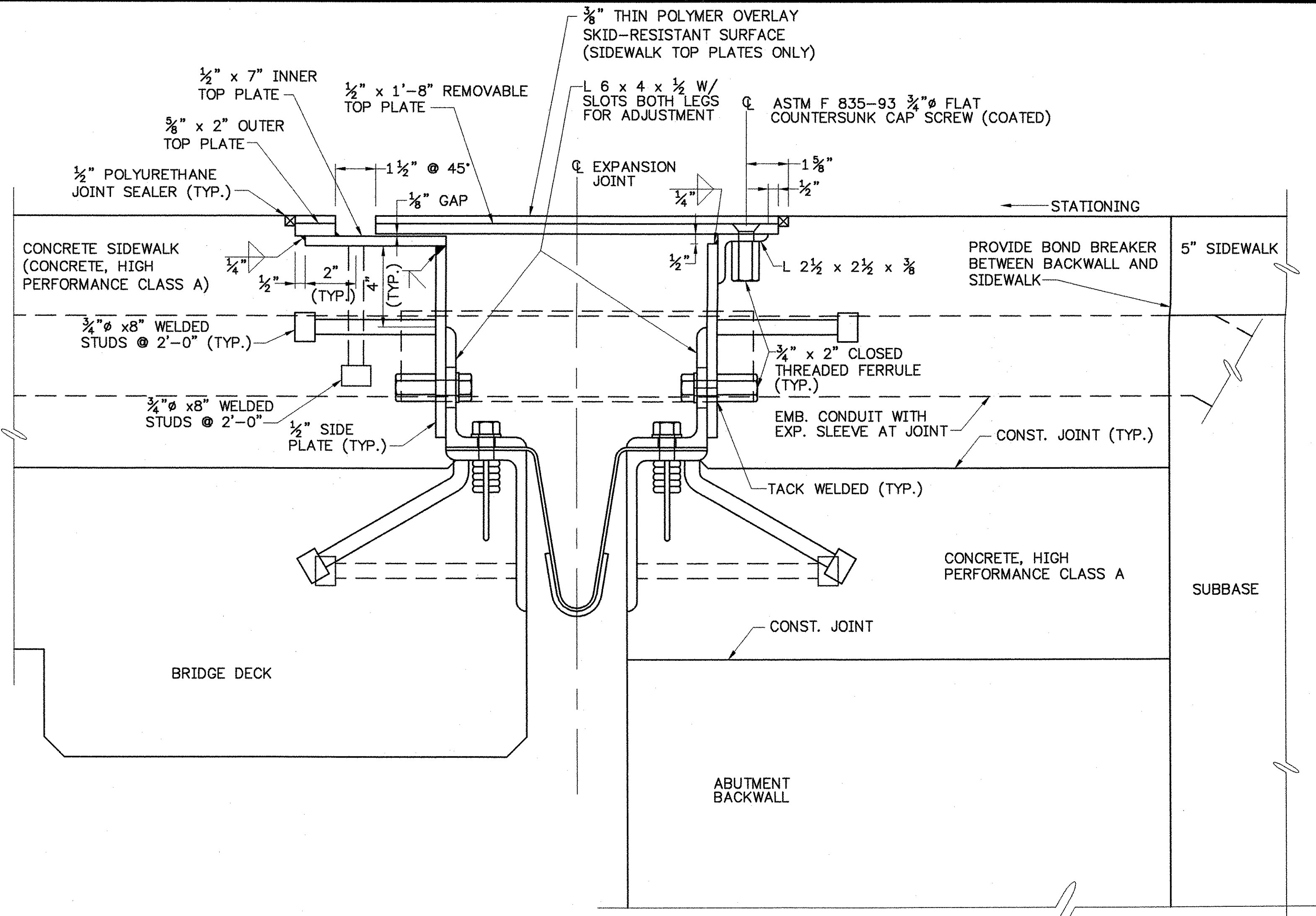

SECTION B - B

SCALE: 3" = 1'-0"
(REFER TO SHEET 46 FOR LOCATION)

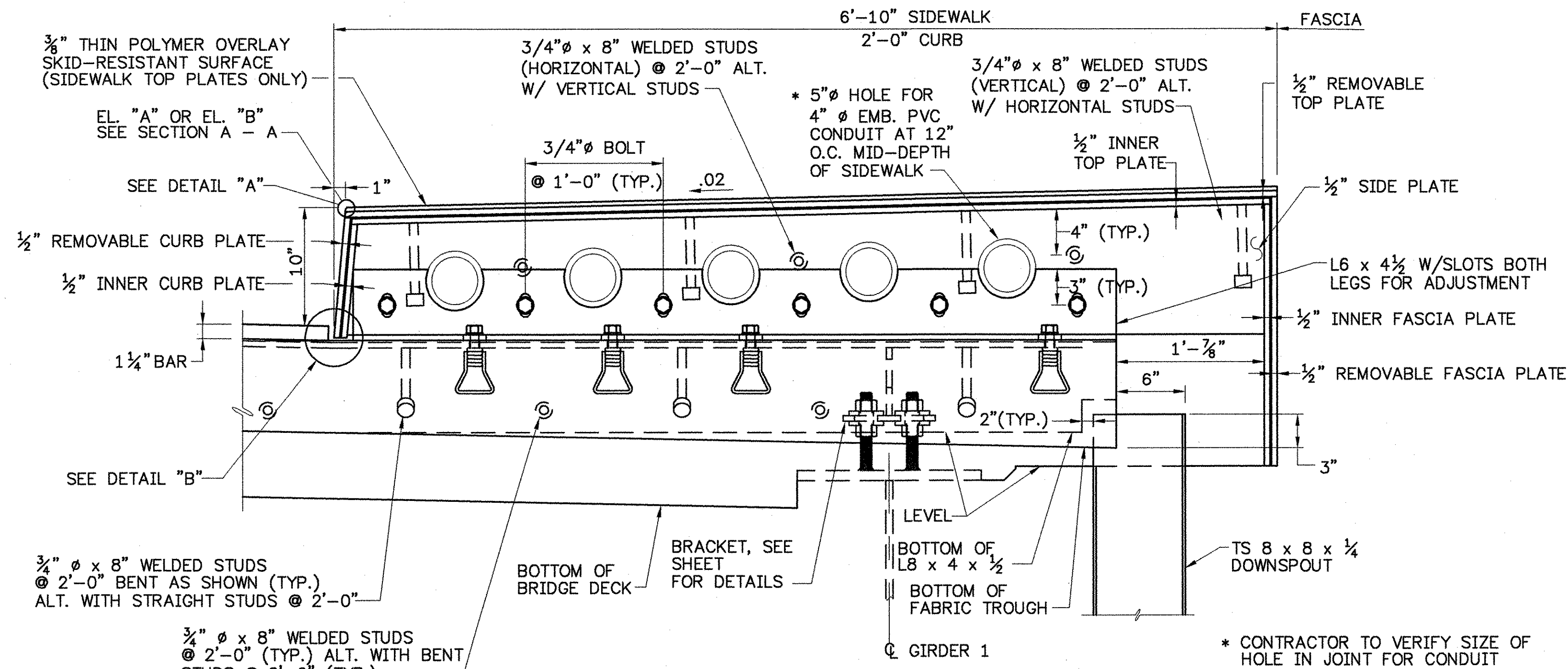

SECTION C - C

SCALE: 1 1/2" = 1'-0"
(REFER TO SHEET 46 FOR LOCATION)

SIDEWALK ELEVATION TABLE		
ABUTMENT	"A"	"B"
NO. 1	479.60	479.61

CURB ELEVATION TABLE		
ABUTMENT	"A"	"B"
NO. 1	479.61	479.62

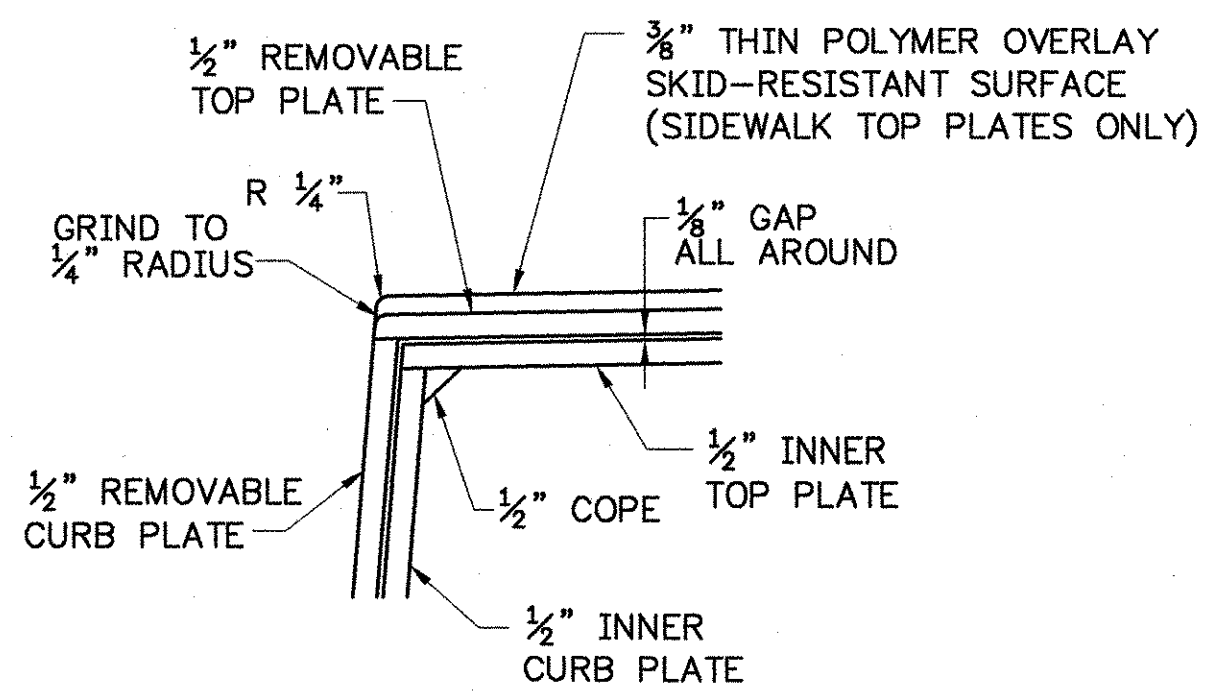

DETAIL "A"

SCALE: 3" = 1'-0"

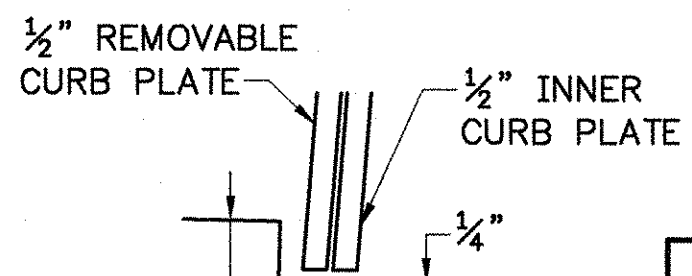

DETAIL "B"

SCALE: 3" = 1'-0"

**STATE OF VERMONT
AGENCY OF TRANSPORTATION**

Town Of	ROYALTON	Bridge No.	21
Highway No.	VT. ROUTE 14	Log Sta.	
		Surv. Sta.	
VT. ROUTE 14 OVER THE WHITE RIVER EXPANSION JOINT DETAILS (2 OF 2)			
Designed By	VAOT/LMM	Drawn By.	VAOT/KBG
Checked By	Date	Bridge Design Supervisor	
CLW/LMM	11/00	LMM	Date 11/00
PROJECT	ROYALTON	PROJECT NO.	BRS 0147(5) S
I.G.C. Info.		Sheet 48 Of 76	
Bridge Sheet No.			



91298_EXPDTL.dwg