

LOUVER SCHEDULE

MODEL	ASSY	QTY	ORDERED DIMS			LOUVER DIMENSIONS		SHIP SECTIONS	COLOR
			A(WIDTH)	B(HEIGHT)	DEDUCT	WIDTH	HEIGHT		
NCS/LSA4W38	A	5	18	18	1/4"	17 3/4"	17 3/4"	1	N/A

FRAME	
6063-T5 extruded aluminum with .080" nominal wall thickness. Formable frame	<input type="checkbox"/>
Flange frame, same mat as above with .125" nominal wall thickness	<input type="checkbox"/>
BLADES	
6063-T5 extruded aluminum with .080" nominal wall thickness. Blades are positioned at 37.5° angle.	<input type="checkbox"/>
SCREEN	
5/8" x .040" expanded flattened aluminum bird screen.	<input type="checkbox"/>
1/2" mesh x .063" aluminum bird screen.	<input type="checkbox"/>
18-16 mesh alum insect screen	<input type="checkbox"/>
No screen.	<input type="checkbox"/>
FINISH	
Mil.	<input type="checkbox"/>
Kynar (opt.)	<input type="checkbox"/>
Baked enamel (modified fluoropolymer, 50% Kynar, opt.)	<input type="checkbox"/>
Pearledize (opt.)	<input type="checkbox"/>
Color Anodize (opt.)	<input type="checkbox"/>
Clear Anodize (opt.)	<input type="checkbox"/>
Color: Ref. Schedule	<input type="checkbox"/>
ACCESSORIES (opt)	
Extended sill.	<input type="checkbox"/>
Clip angles.	<input type="checkbox"/>
Blankoff panel.	<input type="checkbox"/>

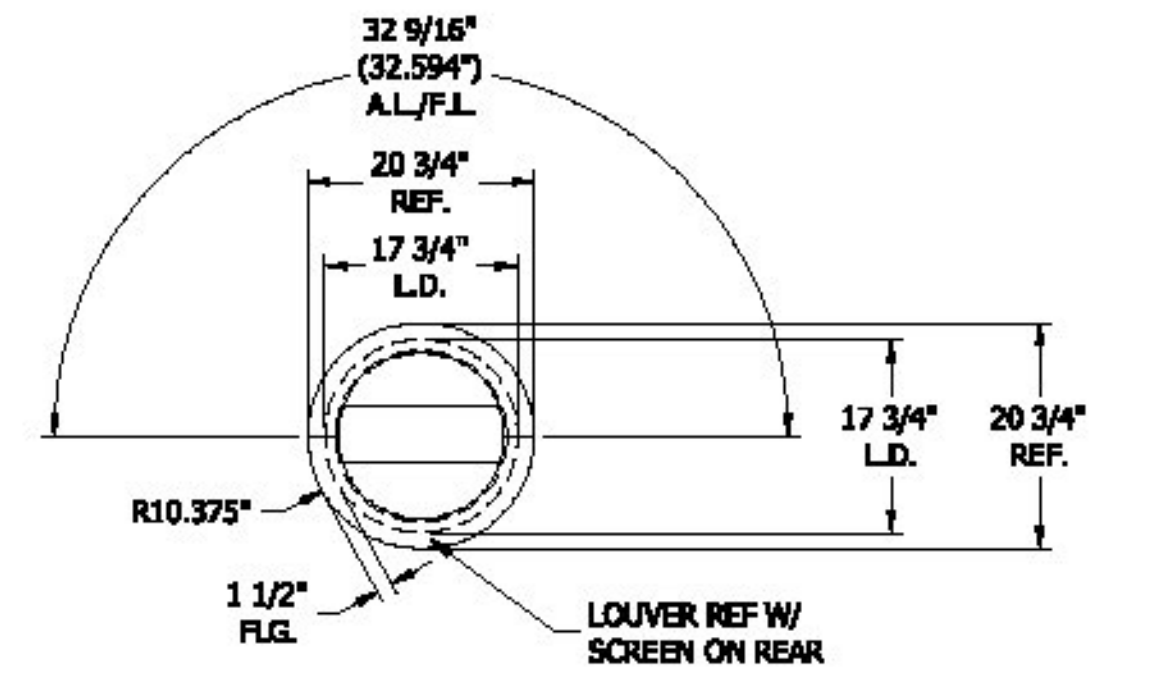
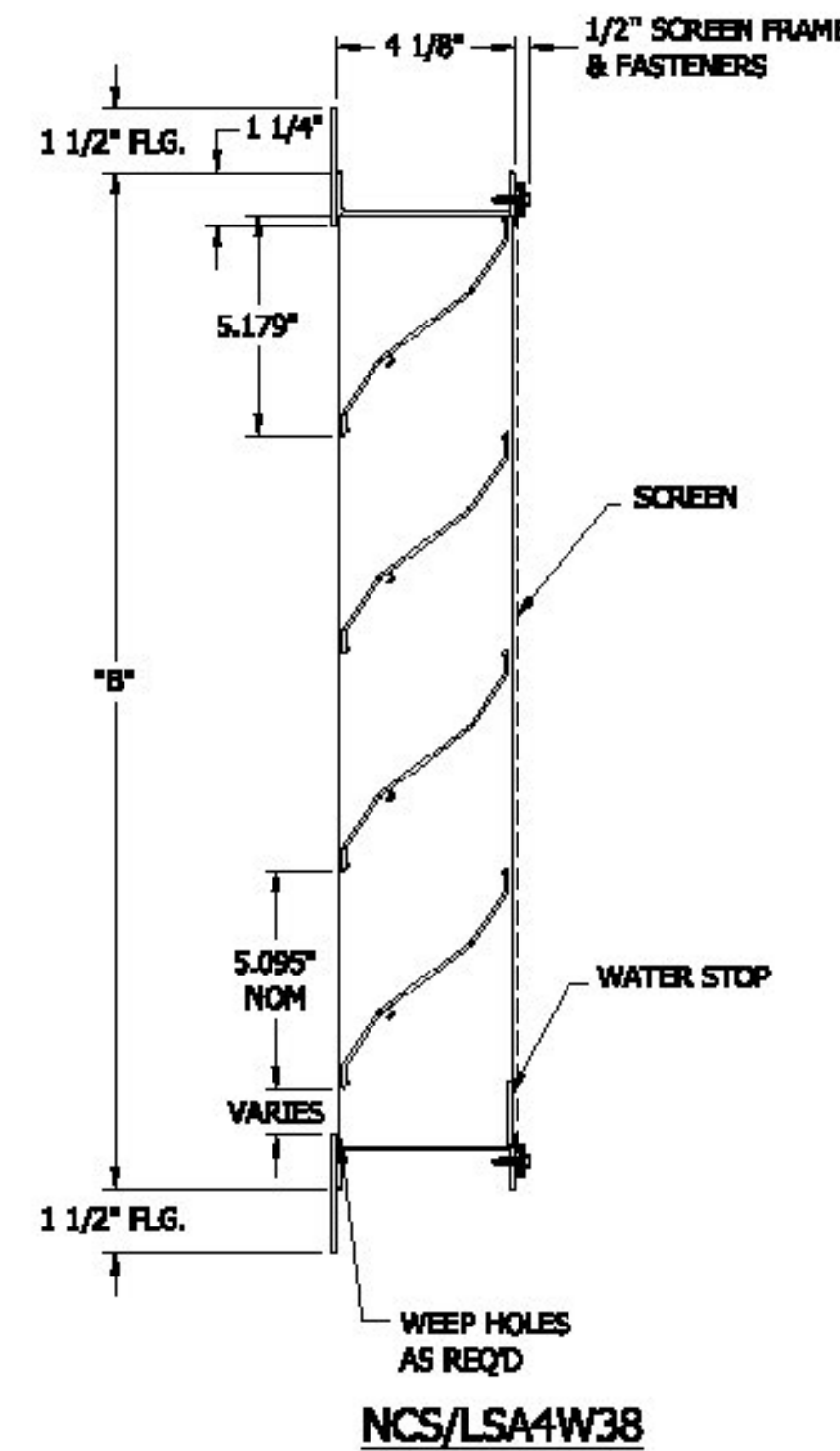

ASSEMBLY "A" N.T.S. NCS/LSA4W38(SHAPE "A") FRONT VIEW

NOTES

- DIMENSIONS SHOWN ARE ACTUAL LOUVER SIZE.
- LOUVER DESIGN INCORPORATES STRUCTURAL SUPPORTS ATTACHED TO REAR OF LOUVER TO WITHSTAND A WINDLOAD OF 20 PSF. REF. SCHEDULE, ASSY, OR PLANVIEW FOR SIZE, QTY, & LOCATION. PERIMETER SUBSTRATE AND ATTACHMENT DESIGN IS NIC.
- INDICATES TAG: LETTER= ASSY #= SHIP SECTION.
- DETAIL BALLOON DESCRIPTION: DETAIL #
- SHOP DRAWINGS ARE PREPARED BASED ON INTERPRETATION OF PURCHASER'S ORDER AND/OR ARCHITECTS/ENGINEERS DRAWINGS AND SPECIFICATIONS. IT IS IMPORTANT THAT THE PURCHASER AND THE INSTALLATION CONTRACTOR REVIEW THESE DRAWINGS DIMENSIONALLY AND FUNCTIONALLY WITH RESPECT TO THE ARCHITECTS INTENT AND VERIFY SIZE, CONFIGURATION AND FIELD CONDITIONS PRIOR TO FABRICATION.

- 6) ABBREVIATIONS
- B.O.D. = BLANK-OFF DIMENSION
 - F.L. = FRAME LENGTH
 - H.H.B.S. = HORIZ. HIDDEN BLADE SUPPORT
 - H.V.B.S. = HIDDEN VERT. BLADE SUPPORT
 - L.D. = LOUVER DIMENSION
 - L.D.D. = LOUVER DOOR DIMENSION
 - N.I.C. = NOT IN CONTRACT
 - O.D. = OVERALL DIMENSION
 - O.C. = ON CENTER
 - OPP. = OPPOSITE
 - R.L.D. = REMOVABLE LOUVER DIMENSION
 - R.O. = ROUGH OPENING
 - SIM = SIMILAR
 - S.D. = SUB-FRAME DIMENSION
 - S.S. = SHIP SECTION
 - S.S.D. = SHIP SECTION DIMENSION
 - TYP = TYPICAL
 - U.N.O. = UNLESS NOTED OTHERWISE

- REQUEST FOR REVISIONS AFTER DRAWINGS ARE RELEASED FOR FABRICATION ARE SUBJECT TO A HANDLING CHARGE PLUS COST OF ANY MATERIALS ORDERED AND/OR FABRICATED RELATIVE TO THIS ORDER.
- SEALING REQUIREMENTS AROUND LOUVERS, BETWEEN ADJOINING SHIP SECTIONS, SILLS, FRAMES AND WATERSTOPS FOR ARCHITECTURAL STYLE CONTINUOUS BLADE LOUVERS SHALL BE THE RESPONSIBILITY OF THE INSTALLATION CONTRACTOR.
- CONTINUOUS ARCHITECTURAL LOUVERED SCREEN BLADES MAY SHIFT DURING SHIPPING. ALIGNMENT OF BLADES AT SHIP SECTIONS IS THE RESPONSIBILITY OF THE INSTALLATION CONTRACTOR. REMOVE AND DISCARD SIDEPLATES AND FASTENERS PRIOR TO ASSEMBLY (NIC).
- NOTCHING OF HVBS AROUND STRUCTURE AND/OR OBSTRUCTIONS IN THE FIELD SHALL BE THE RESPONSIBILITY OF INSTALLATION CONTRACTOR. IF CONTINUOUS ANGLES AND/OR EXTENDED SILLS ARE ORDERED, NOTCHING OF THE ANGLES AND SILLS AROUND OBSTRUCTIONS (HVBS & FIELD CONDITIONS) SHALL BE THE RESPONSIBILITY OF THE INSTALLATION CONTRACTOR.

- MULTIPLE SECTION LOUVER & SCREEN ASSEMBLIES AND THEIR FIELD ASSEMBLY COMPONENTS SHALL BE FACTORY PUNCHED.
- FIELD MODIFICATIONS OF LOUVER COMPONENTS SHALL BE REVIEWED AND APPROVED BY LOUVER MANUFACTURER.
- ATTACHMENT TO SURROUNDING STRUCTURE IS REQUIRED AT TOP AND BOTTOM OF EACH BLADE SUPPORT (HVBS) AS A MINIMUM REQUIREMENT. (N.I.C.)
- IF BITUMINOUS COMPOUNDS ARE REQUIRED BETWEEN DISSIMILAR METALS OR LOUVERS AND OTHER SURFACES, IT IS THE RESPONSIBILITY OF THE INSTALLATION CONTRACTOR TO SUPPLY AND PROPERLY APPLY IT.
- COLOR: REF SCHEDULE
- REF. DWGS: 01 FOR SCHED, SPEC, ASSEMBLY & NOTES

SUBMITTAL

NYSTROM

Right to site.

800 7nd Avenue N.
Minnetonka, Minnesota 55345
Phone (952) 231-6700
Fax (952) 231-6700

T. BUCK CONSTR. INC.

NYSTROM, INC.

CH: 2098235

P.O. TBUCKCONST

(F1)

DATE	DLB	DATE
1/27/14	NLT	1/27/14
1/27/14	NLT	1/27/14
BRAD GUMZ (N.I.C.)		
NCS/LSA4W38 SCHED, SPEC & NOTES ASSEMBLY		
1	1	NONE

2098235-01