

ONE - GIRDER - G3C (DEV)

1. FOR GIRDER STANDARD DETAILS SEE DWG. X1 & X2.
2. FOR CAMBER DIAGRAM SEE DWG. C1.
3. FOR FLANGE DIAGRAM SEE DWG. F4 & F5.
4. FOR GENERAL NOTES SEE SHT. GNI.

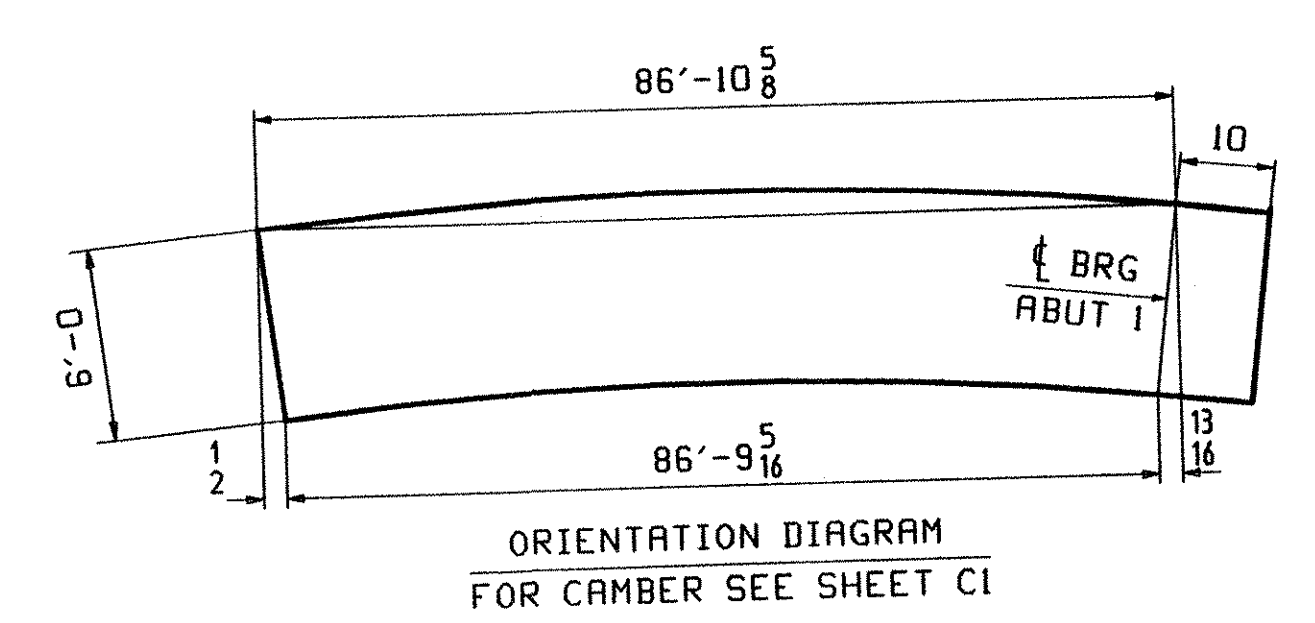
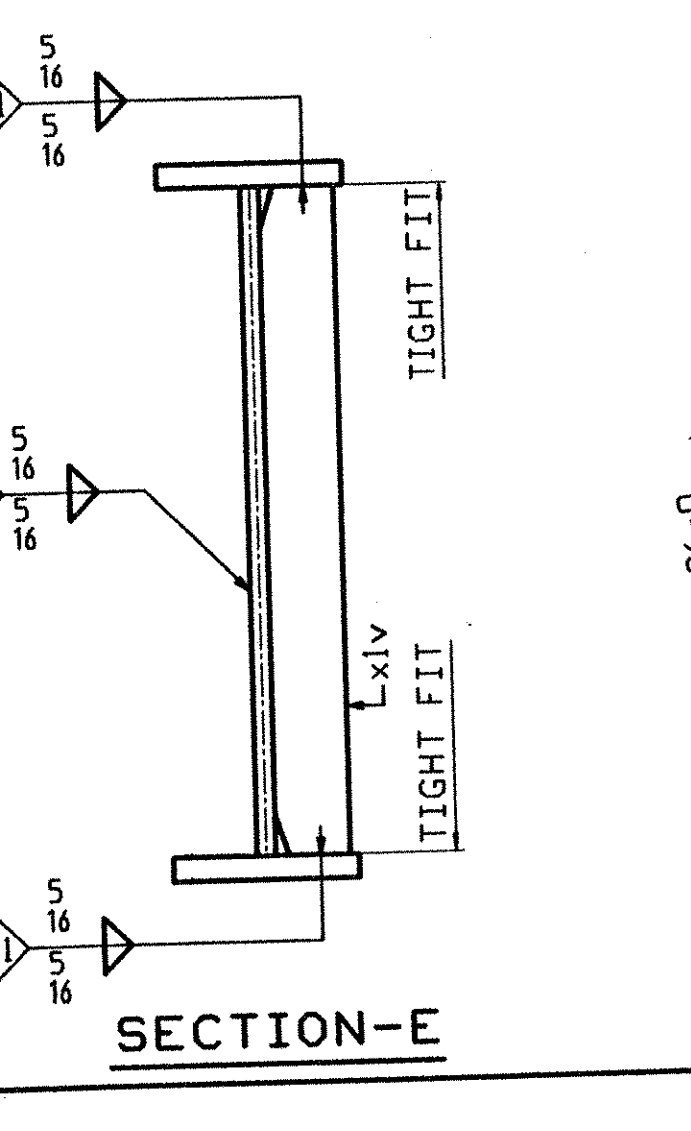
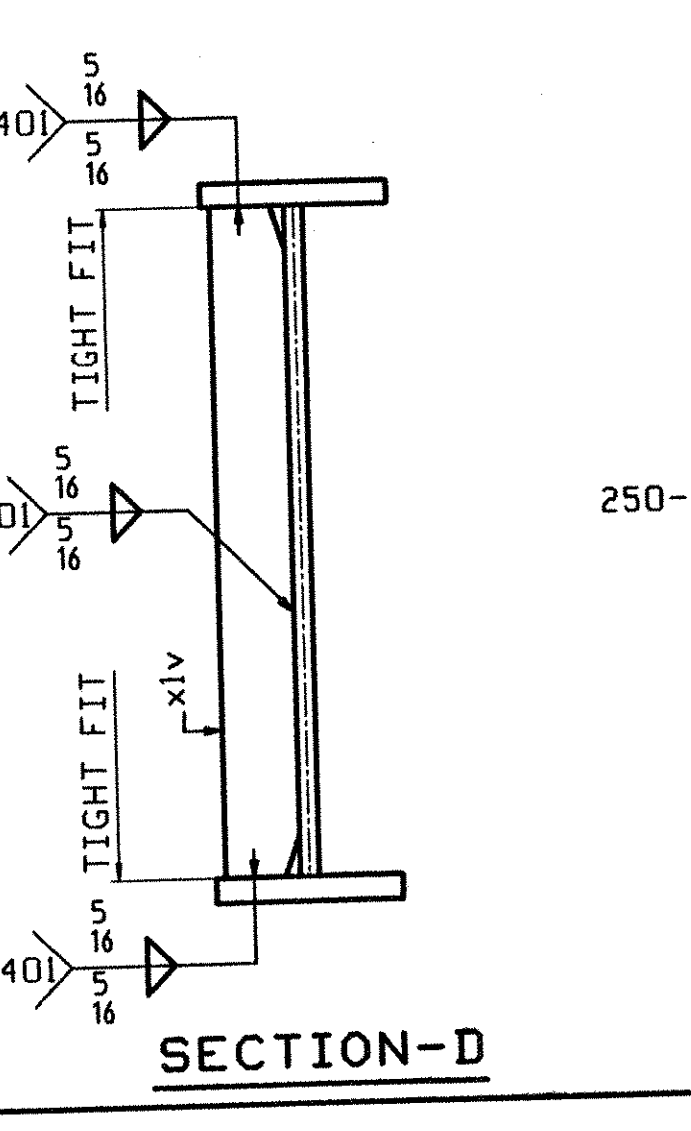
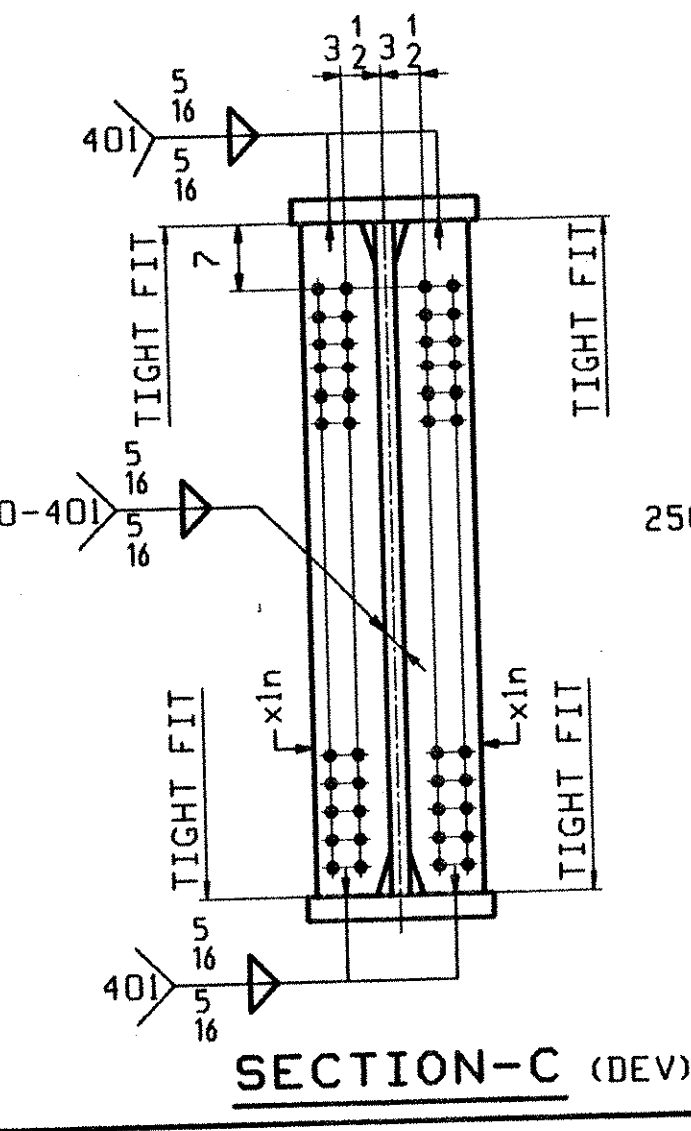
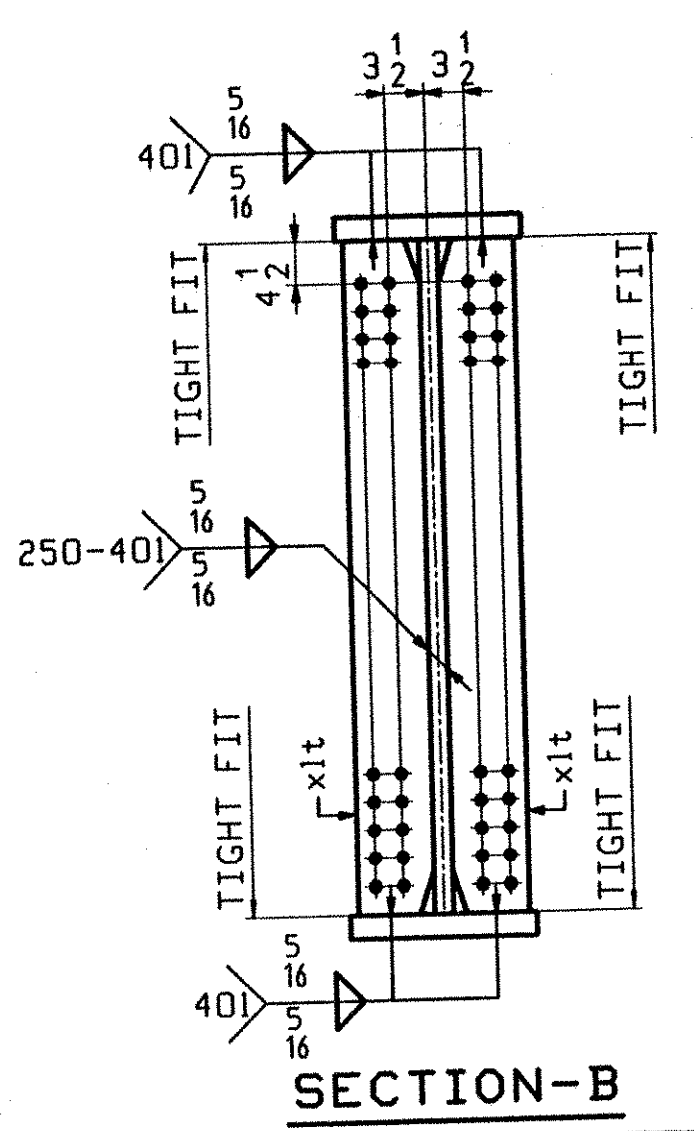
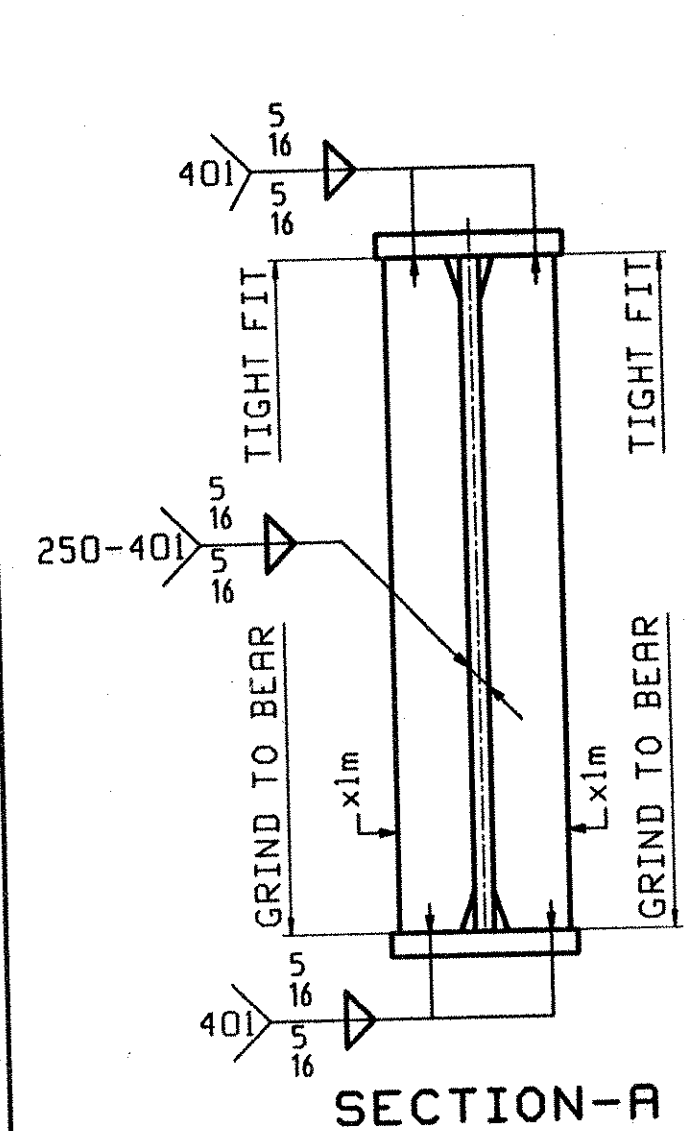
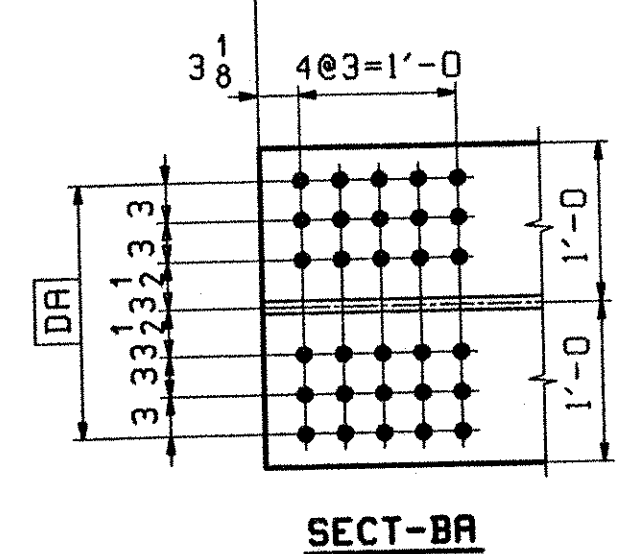

| ABM INFO | | SHIP | | BILL OF MATERIAL | | JOB NO. | | DRAWING NO. | | REV. |
|----------|------|------|-----|------------------|-------------|-----------|---------|---------------------|----|-------------------|
| PAGE | LINE | MARK | QTY | MARK | MATERIAL | LENGTH FT | INCHES | REMARKS | MT | PROCUREMENT NOTES |
| | | G3C | 1 | | GIRDER | | | | | 25248 |
| 5 | L | | 1 | wa | PL 1/2 x 24 | 59 | 0 3/8 | (M270-50WT2) (H2-3) | | |
| 6 | G | | 1 | wb | PL 1/2 x 24 | 28 | 8 1/2 | (M270-50WT2) (H2-3) | | |
| 3 | Q | | 1 | ta | PL 1 x 16 | 48 | 0 9/16 | (M270-50WT2) (H2-3) | | |
| 3 | U | | 1 | tb | PL 1 x 16 | 39 | 8 | (M270-50WT2) (H2-3) | | |
| 1 | S | | 1 | ba | PL 1/4 x 24 | 65 | 11 5/16 | (M270-50WT2) (H2-3) | | |
| 4 | E | | 1 | bb | PL 1 x 16 | 21 | 8 | (M270-50WT2) (H2-3) | | |
| 7 | P | | 12 | xlt | PL 1/2 x 8 | 6 | 0 | (M270-50WT2) (H2-3) | | |
| 7 | P | | 2 | xln | PL 1/2 x 8 | 6 | 0 | (M270-50WT2) (H2-3) | | |
| 7 | M | | 2 | xlm | PL 1 x 8 | 6 | 0 | (M270-50WT2) (H2-3) | | |
| 7 | P | | 3 | xlv | PL 1/2 x 8 | 6 | 0 | (M270-50WT2) (H2-3) | | |

| | | | | | | | | | | | |
|---|-----------------------------------|------|-----|-----|-----|------|-----|---------------------|------------|---------------|----------|
| OUT FOR APPROVAL | 9-9-02 | | | | | | | | | | |
| OUT FOR APPROVAL | | | | | | | | | | | |
| ISSUED TO SHOP | | | | | | | | | | | |
| FIELD & OFFICE | | | | | | | | | | | |
| REV. | REMARKS | DATE | DWN | CHK | APP | Q.A. | NO. | DIA. | LGT | TYPE | WASHER |
| | MATERIAL: | | | | | | | | | | |
| | M270-50W | | | | | | | | | | AS NOTED |
| | ELECTRODES: | | | | | | | | | | |
| | | | | | | | | | | | |
| | HOLES: | | | | | | | | | | |
| | 15/16" φ (UN) | | | | | | | | | | |
| | SHOP BOLTS: | | | | | | | | | | |
| | | | | | | | | | | | |
| SURFACE PREP. & PAINT: | | | | | | | | | | | |
| -STEEL WITHIN 10'-0" ENDS OF GIRDERS SHALL BE PAINTED (SEE GNI) | | | | | | | | | | | |
| -ALL OTHER STEEL SHALL BE BLAST CLEANED AND LEFT UNPAINTED. | | | | | | | | | | | |
| DESCRIPTION: | GIRDER - G3C | | | | | | | | DRAWN BY | DATE | |
| JOB: | VT RTE 9 OVER THE DEERFIELD RIVER | | | | | | | | ATD | 08/27 | |
| | BRIDGE NO. 25A | | | | | | | | CHKD BY | | |
| | SEARSBURG, VERMONT | | | | | | | | DO | 09/03 | |
| | CONTRACTOR: J.A. McDONALD | | | | | | | | APPROV BY | | |
| | | | | | | | | | SUPERVISOR | M. J. GRIFFIN | |
| PROJ NO. | PROJ. NHF 010-1(18) | | | | | | | | Q.A. | | |
| CUSTOMER: VERMONT AGENCY OF TRANSPORTATION | | | | | | | | | | | |
| CASCO BAY STEEL STRUCTURES, INC. | | | | | | | | | | | |
| 75 SPRING HILL ROAD | | | | | | | | JACO, MAINE 04072 | JOB NO. | DRG. NO. | |
| PHONE (207) 282-7360 | | | | | | | | FAX. (207) 282-1179 | 166 | 13 | |
| REV. 13 | | | | | | | | | | | |

663-EP 25#-9415