

**TYPICAL BRIDGE SECTION - BR 25A**  
(NOT TO SCALE)

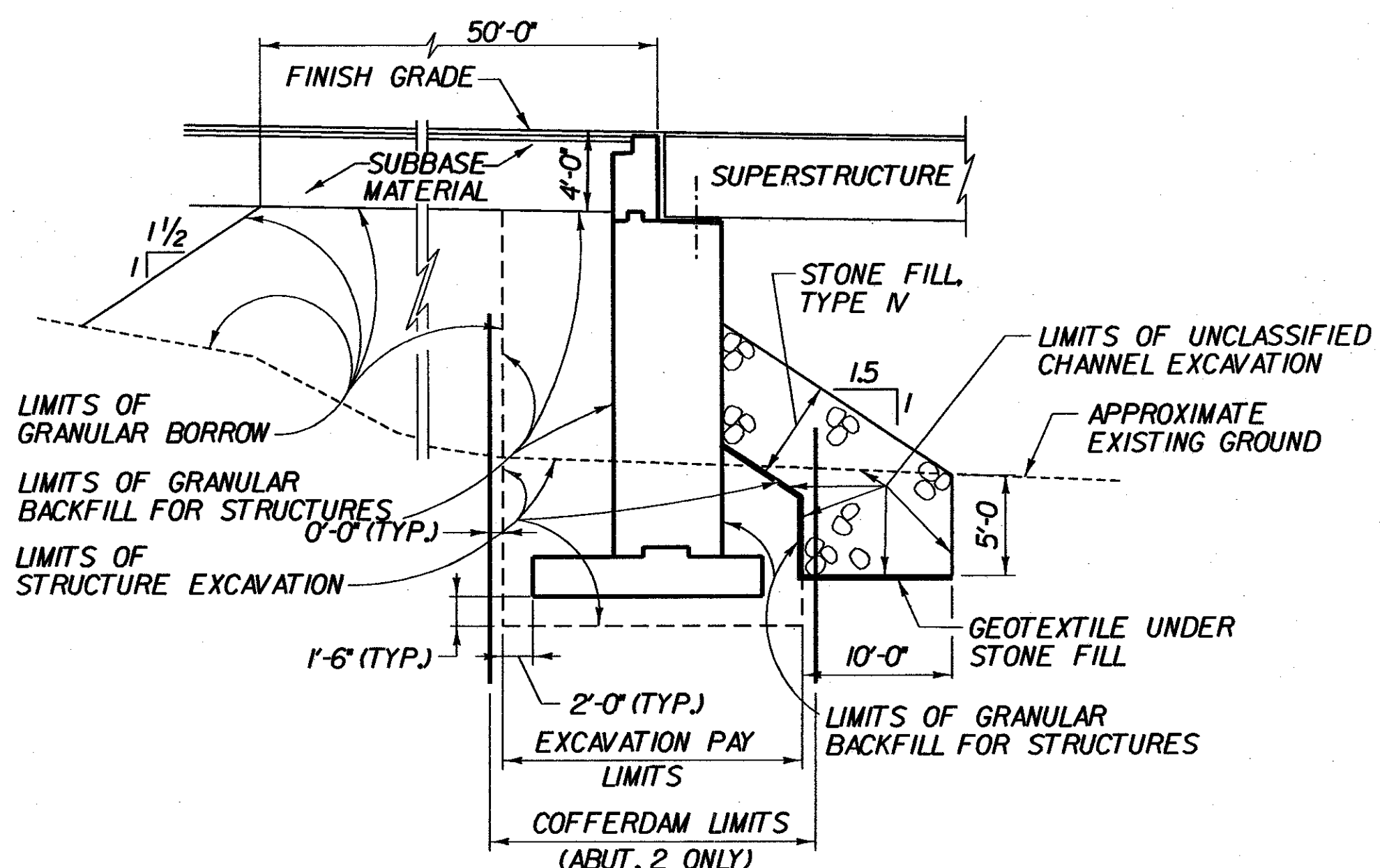

**TYPICAL ABUTMENT SECTION - BR 25A**  
(NOT TO SCALE)

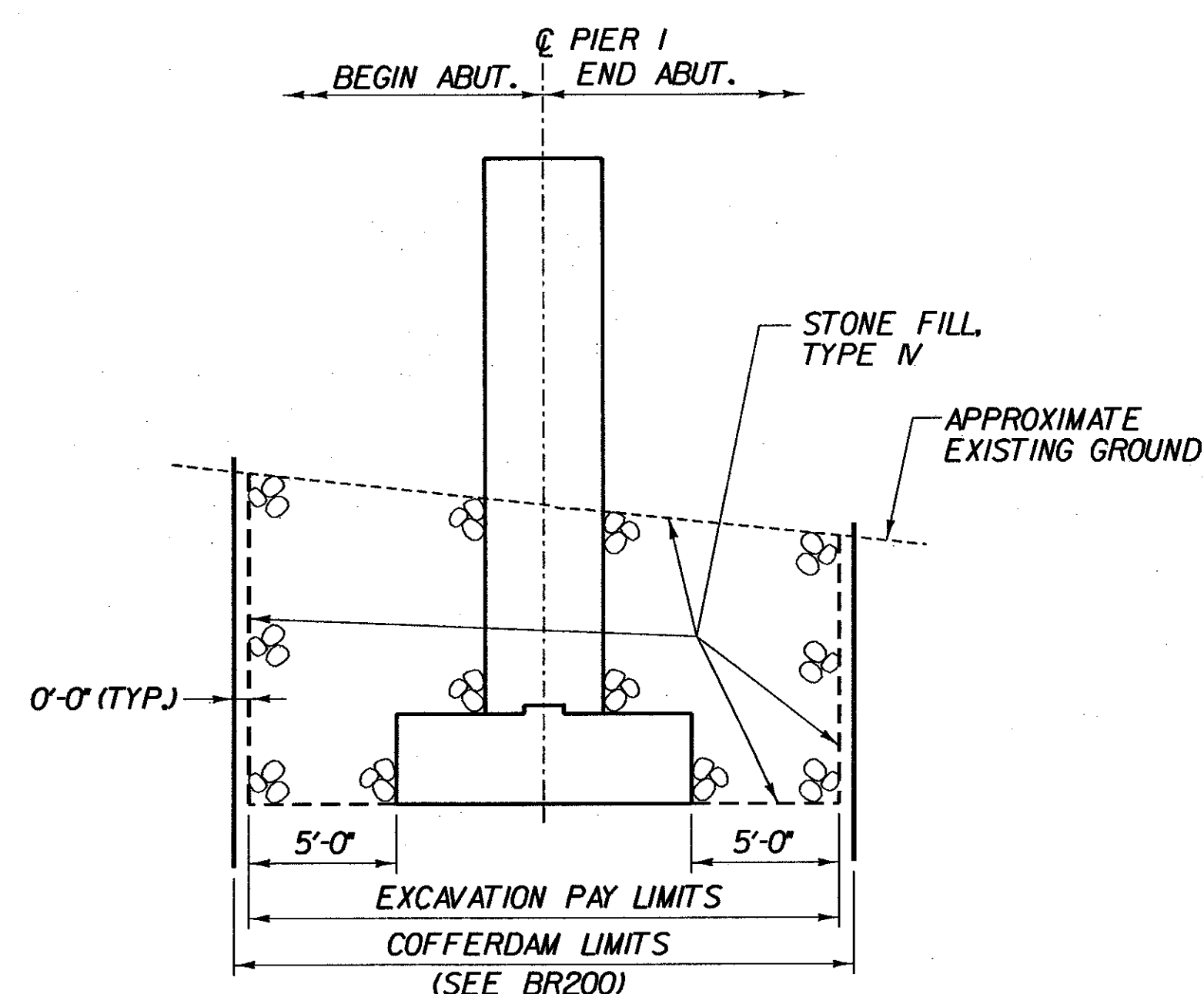

**TYPICAL PIER SECTION - BR 25A**  
(NOT TO SCALE)

**NOTE:**  
COFFERDAM SIZE TO BE DETERMINED BY THE CONTRACTOR.  
THE PAY LIMITS OF COFFERDAM EXCAVATION, "ROCK" OR "EARTH" SHALL BE 5'-0" OUTSIDE THE FOOTING PERIMETER FOR PIER 1 AND 2'-0" OUTSIDE THE FOOTING PERIMETER FOR ABUTMENT 2.  
IF A COFFERDAM IS CONSTRUCTED WHICH IS LARGER THAN THE COFFERDAM EXCAVATION PAY LIMITS, PAYMENT FOR ALL UNCLASSIFIED CHANNEL EXCAVATION, INCLUDING THAT PORTION WHICH IS INSIDE THE COFFERDAM BUT OUTSIDE THE COFFERDAM EXCAVATION PAY LIMITS, WILL BE MADE AT THE CONTRACT UNIT PRICE FOR UNCLASSIFIED CHANNEL EXCAVATION.

**FINAL HYDRAULICS REPORT**

HYDROLOGIC DATA		PROPOSED STRUCTURE	
DRAINAGE AREA: 97.4 SQUARE MILES		STRUCTURE TYPE: TWO SPAN PLATE GIRDER BRIDGE	
CHARACTER OF TERRAIN: MOUNTAINOUS AND FORESTED		CLEAR SPAN(NORMAL TO STREAM): 242 FT	
CHARACTER & TYPE OF STREAM: PERENNIAL, FLASHY, SUB TO SUPERCRITICAL AND SINUOUS		VERTICAL CLEARANCE ABOVE STREAMBED: 22 FT	
NATURE OF STREAMBED: GRAVEL, COBBLES TO LARGE BOULDERS		WATERWAY OF FULL OPENING: 4300 FT	
02.33: 2700 cfs	050: 1500 cfs	WATER SURFACE ELEV. @ 02.33 = 160.2 FT	VELOCITY = 6.3 fpm
010: 6000 cfs	0100: 13800 cfs	010 = 162.5 FT	010 = 8.5 fpm
025: 8900 cfs	0500: 22500 cfs	025 = 164.1 FT	025 = 10.5 fpm
		050 = 165.2 FT	050 = 1.5 fpm
		0100 = 166.2 FT	0100 = 12.4 fpm
DATE OF FLOOD OF RECORD: SEPTEMBER 1938		IS THE ROADWAY OVERTOPPED BELOW THE O100? NO FREQUENCY: ABOVE O100	
WATER SURFACE ELEV.: UNKNOWN ESTIMATED DISCHARGE: UNKNOWN		RELIEF ELEVATION: 1632.2 FT DISCHARGE OVER ROAD @ O100: NONE	
NATURAL STREAM VELOCITY @ FLOOD OF RECORD @ O50 = 8.1 fpm		AVERAGE LOW ELEVATION OF SUPERSTRUCTURE: 1624.9	
ICE CONDITIONS: MODERATE DEBRIS: MODERATE		VERTICAL CLEARANCE @ O50 = 9.7 FT (AVERAGE CLEARANCE)	
DOES THE STREAM REACH MAXIMUM HIGHWATER ELEVATION RAPIDLY? YES		SCOUR: O50: 9 FT OF PIER SCOUR AND NO CONTRACTION SCOUR	
IS ORDINARY RISE RAPID? YES		REQUIRED CHANNEL PROTECTION: TYPE IV STONE FILL	
IS STAGE AFFECTED BY UPSTREAM OR DOWNSTREAM CONDITIONS? YES			
IF YES, DESCRIBE: SEARSBURG AND SOMERSET RESERVOIRS ARE UPSTREAM OF THIS SITE			
WATERSHED STORAGE: 4% HEADWATERS: UNIFORM THROUGHOUT WATERSHED X			
IMMEDIATELY ABOVE SITE			
EXISTING STRUCTURE		PERMIT INFORMATION	
STRUCTURE TYPE: N/A - BRIDGE 25A IS A NEW STRUCTURE YEAR BUILT: _____		AVERAGE DAILY FLOW: 200 CFS*	
CLEAR SPAN (NORMAL TO STREAM): _____		ORDINARY LOW WATER: 90 CFS*	
VERTICAL CLEARANCE ABOVE STREAMBED: _____		ORDINARY HIGH WATER: 1200 CFS*	
WATERWAY OF FULL OPENING: _____		DEPTH: 1 FT	
DISPOSITION OF STRUCTURE: _____		DEPTH: 3 FT	
TYPE OF MATERIAL UNDER SUBSTRUCTURE: _____			
WATER SURFACE ELEV. @ 02.33: _____ VELOCITY: _____			
010: _____			
025: _____			
050: _____			
0100: _____			
LONG TERM STREAM BED CHANGES: _____			
IS THE ROADWAY OVERTOPPED BELOW THE O100? _____ FREQUENCY: _____			
RELIEF ELEVATION: _____ DISCHARGE OVER ROAD @ O100: _____			
UPSTREAM STRUCTURE #1: TOWN: SEARSBURG DISTANCE: 0.3 MI			
HIGHWAY NO.: VT ROUTE 9 STRUCTURE NO.: 25			
STRUCTURE TYPE: THREE SPAN CONCRETE T-BEAM BRIDGE			
CLEAR SPAN: 105 FT CLEAR HEIGHT: 20 FT			
YEAR BUILT: 1934 FULL WATERWAY: 1700 SQ FT			
UPSTREAM STRUCTURE #2: TOWN: _____ DISTANCE: _____			
HIGHWAY NO.: _____ STRUCTURE NO.: _____			
STRUCTURE TYPE: _____			
CLEAR SPAN: _____ CLEAR HEIGHT: _____			
YEAR BUILT: _____ FULL WATERWAY: _____			
DOWNSTREAM STRUCTURE: TOWN: WILMINGTON DISTANCE: 1.5 MI			
HIGHWAY NO.: TH-31 STRUCTURE NO.: 57			
STRUCTURE TYPE: SINGLE SPAN PLATE GIRDER BRIDGE			
CLEAR SPAN: 96 FT CLEAR HEIGHT: 13 FT			
YEAR BUILT: 1985 FULL WATERWAY: 1200 SQ FT			

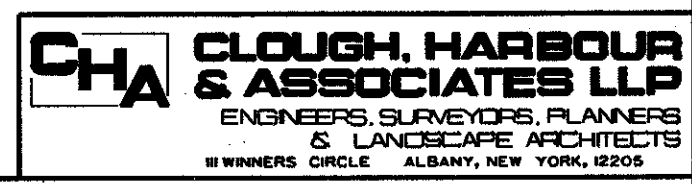

**DESIGN CRITERIA:**

- DESIGN LIVE LOAD AASHTO HS-20
- DESIGN SPAN 293'-5 1/2"
- ALLOWABLE LOAD FOR SPREAD FOOTINGS ON SOIL 4 TSE ON LEDGE
- ALLOWABLE LOAD FOR PILING SEE DRILLED SHAFT NOTES BR3 TYPE SEE DRILLED SHAFT NOTES BR3 ESTIMATED LENGTH SEE DRILLED SHAFT NOTES BR3
- STRUCTURAL STEEL AASHTO M270 GRADE 50 W UNPAINTED
- REINFORCING STEEL AASHTO GRADE 60 W3 BULLET STEEL
- CONCRETE CLASS A (OC/OA) - f'c=4000 PSI CLASS B (HPC-B) - f'c=3500 PSI CLASS A (HPC-A) - f'c=4000 PSI

**TRAFFIC MAINTENANCE:**

- IS TRAFFIC TO BE MAINTAINED? N/A IF YES, ON EXISTING STRUCTURE OR ON TEMPORARY BRIDGE
- TEMPORARY BRIDGE REQUIREMENTS: ONE OR TWO WAY TRAFFIC CONTROL SIGNALS REQUIRED

MINIMUM CLEAR SPAN (NORMAL TO STREAM): \_\_\_\_\_ VERTICAL CLEARANCE ABOVE STREAMBED: \_\_\_\_\_

WATERWAY OF FULL OPENING: \_\_\_\_\_

ARE SIDEWALKS REQUIRED? \_\_\_\_\_ IF SO, ON WHAT SIDE? \_\_\_\_\_

STRUCTURE TYPE: \_\_\_\_\_

LOADING LEVELS (LOAD FACTOR)	LOAD FACTOR LOAD RATING (TONS)						
	H	HS	3S2	6 AXLE	3A,STR.	4A,STR.	5A,SEMI
INVENTORY A = 2.17; B = L00	32	58					
POSTED A = 1.55; B = L40	45	82	314		284	287	302
OPERATING A = 1.30; B = L67	54	97	374	391	338	342	

RF = 0.9M<sub>u</sub> - 1.3 M<sub>DL</sub> / (A x M<sub>LL+I</sub>)

PROJECTED TRAFFIC DATA

YEAR	ADT	DHV	% D	% T	% ADTT
2000	-	-	-	-	-
2020	-	-	-	-	-

20 year ESAL for flexible pavement from 2000 to 2020: 4,825,000  
40 year ESAL for flexible pavement from 2000 to 2040: 17,225,000  
Design speed 100 MPH

**STATE OF VERMONT AGENCY OF TRANSPORTATION**

Town Of SEARSBURG Bridge No. 25A  
Log Sta.  
Highway No. VT. RTE. 9 Surv. Sta.

**VT. RTE. 9 OVER DEERFIELD RIVER**

**PRELIMINARY INFORMATION - BR 25A**

Designed By D. VIENI Drawn by K. DETRICK  
Checked By M. OLSTAD Date 2/2002 Bridge Design Supervisor M. OLSTAD Date 2/2002

PROJECT SEARSBURG - WILMINGTON PROJECT NO. NHF 010-1018

L.G.C. Info.  
Bridge Sheet No. BR301 Sheet 166 OF 435