

(X)
1'-10
2'-2
5'-10
6'-2
9'-10
10'-2
13'-10
14'-2
17'-10
18'-2
21'-10
22'-2
25'-10
26'-2
29'-10
30'-2
33'-10
34'-2
37'-10
38'-2
41'-10
42'-2
45'-10
46'-2
49'-10
50'-2
53'-10
54'-2
57'-10
58'-2
61'-10
62'-2
65'-10
66'-2
68'-10
69'-2
72'-10
73'-2
75'-10
76'-2
79'-10
80'-2
83'-10
84'-2
87'-10
88'-2
91'-10
92'-2
95'-10
96'-2
99'-10
100'-2

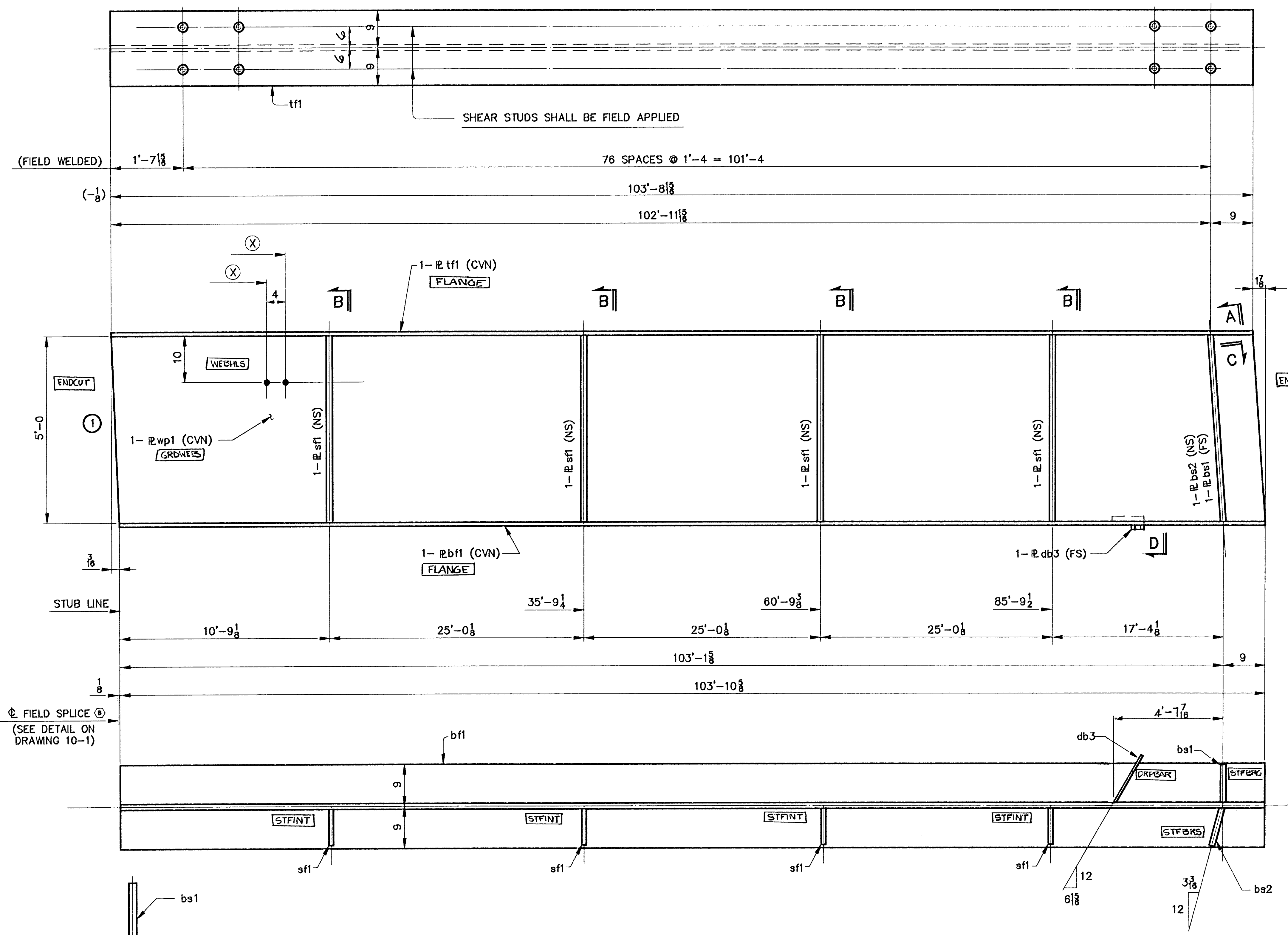

ONE ~ GIRDER ~ G1C
GIRDER

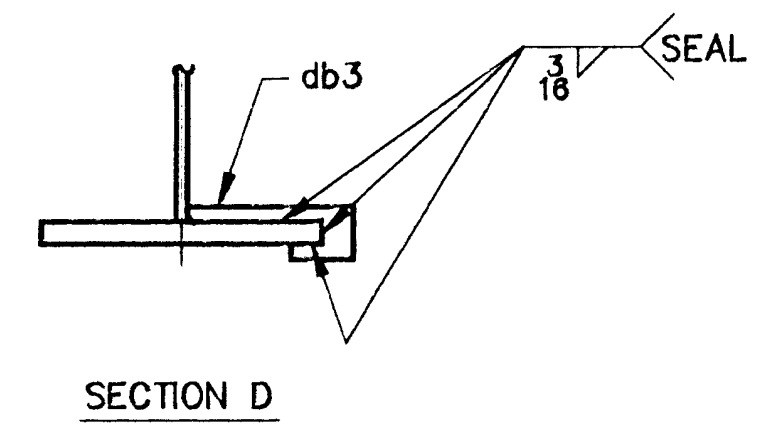
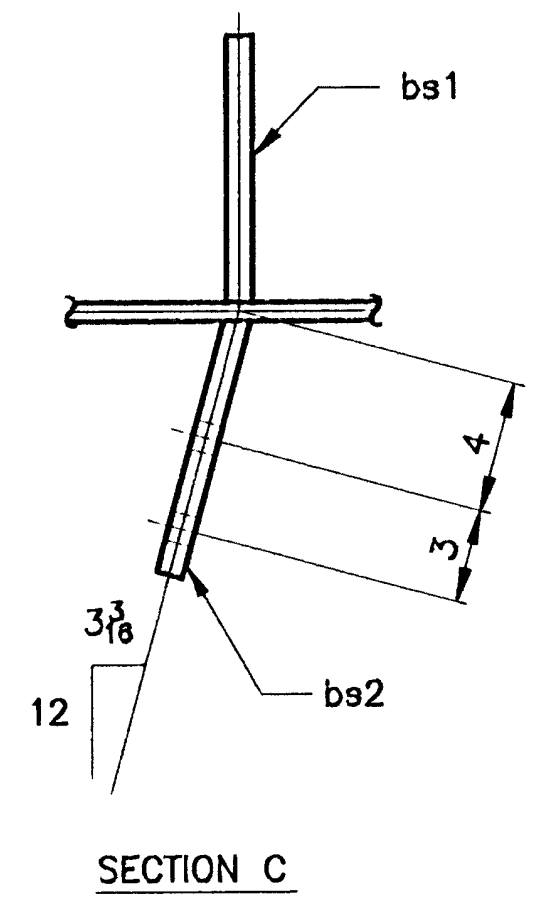

SHIP MARK				BILL OF MATERIAL			WORK ORDER NO.	DRAWING NO.	REV.
							15713	10-21	
NO.	MARK	SHAPE	LENGTH	ITEM NO.	WT.	REMARKS			
G1C	ONE	GIRDER							
6-F-2	1	wp1	R 3/8 x 60	103	10 1/8	1 3 13247	(CVN)		
6-C-A	1	tf1	R 1 1/8 x 18	103	8 1/8	1 9 7149	(CVN)		
6-C-B	1	bf1	R 1 1/8 x 18	103	10 3/8	1 5 7158	(CVN)		
6-C-H	1	bs1	R 7/8 x 8 1/2	5	0	2 1 127	F2E		
6-C-J	1	bs2	R 7/8 x 8 1/2	5	0	2 1 127	F2E		
6-C-G	4	sf1	R 1/2 x 8	5	0	2 2 272	F1E		
6-C-K	1	db3	R 1/4 x 3 1/8	1	0 1/8	2 13 3			
							28083	#	

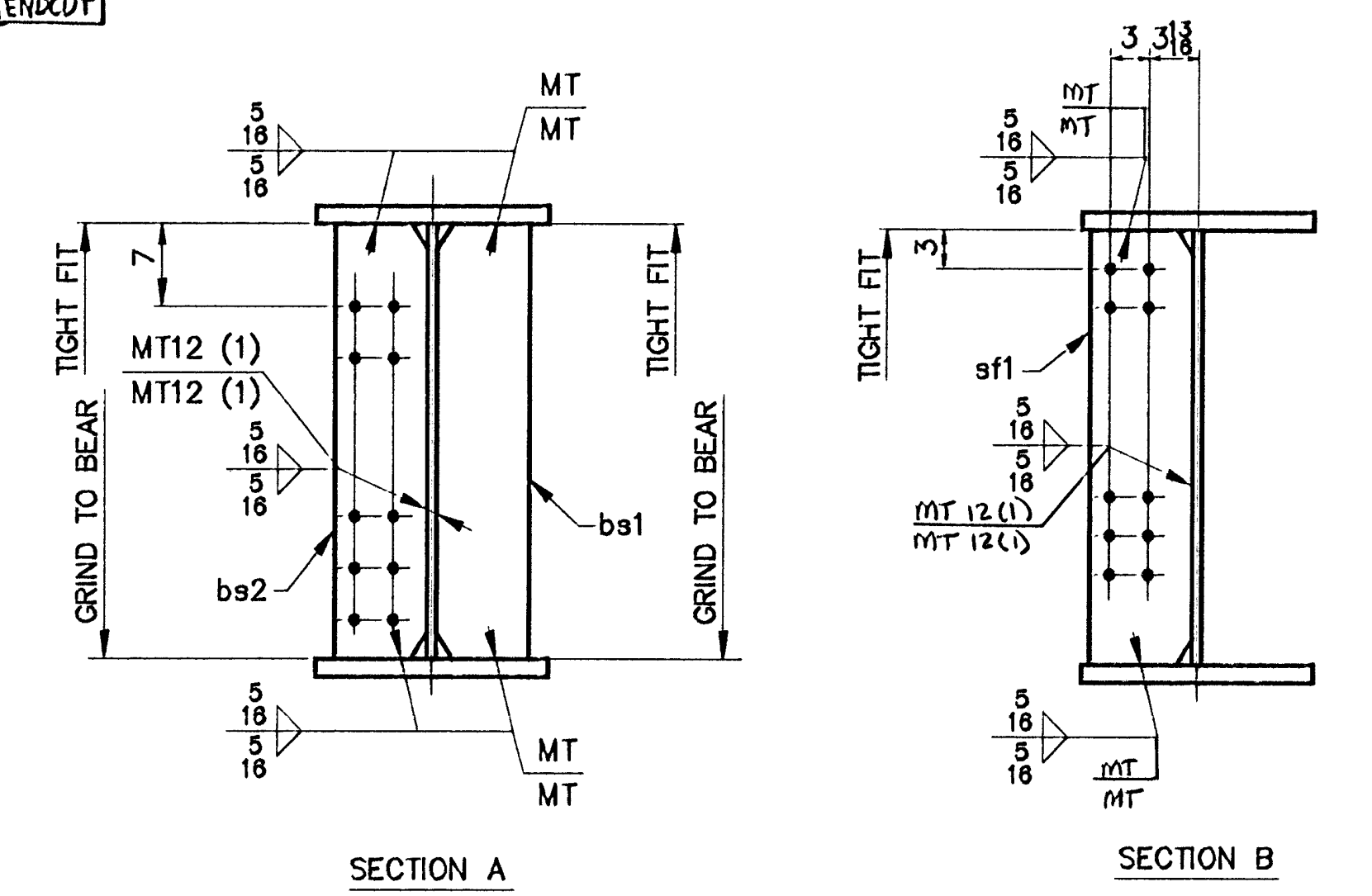

- NOTES
1. FOR CAMBER DIAGRAM SEE DRAWING 10-6.
 2. FOR GIRDER STANDARD DETAILS SEE DRAWING 10-3.
 3. (CVN) DENOTES CHARPY TEST REQUIRED.

STEEL: ASTM	<input type="checkbox"/> A36	<input type="checkbox"/> A572 GR.	<input checked="" type="checkbox"/> A709 GR. 50W	<input type="checkbox"/> Unless Noted		
WELDING ELECTRODE:	<input type="checkbox"/> E70	<input checked="" type="checkbox"/> See Welding Proc.	<input type="checkbox"/> None			
HOLES:	<input type="checkbox"/> 13/16	<input checked="" type="checkbox"/> 15/16	<input type="checkbox"/> 1-1/16	<input type="checkbox"/> Unless Noted	<input type="checkbox"/> As Noted	<input type="checkbox"/> None
PAIN:	<input checked="" type="checkbox"/> None	<input type="checkbox"/> Shop Coat	<input type="checkbox"/> Galv. After Fab.	<input type="checkbox"/> Unless Noted		
SPECIAL PAINT:	NONE					
SPECIAL CLEANING:	<input checked="" type="checkbox"/> Blast Clean	<input type="checkbox"/> SSPC SP10	<input type="checkbox"/> None			
ITEM NO.	506.55	BRIDGE NO.	44	PROJ. NO.	BRS-RS 0113 (8)	
TITLE: GIRDER ~ G1C						
APPROVED:	PRINT DIST.					
5	10-12-96	APPR.	National Eastern Corporation			
ORIG	12-1-96	FAB.	Plainville, Connecticut			
5	11-13-96	APP	JOB: U.S. ROUTE 5 OVER BLACK RIVER			
01016	4-3-97	VAT	SPRINGFIELD, VERMONT			
CUSTOMER: WINTERSETT, INC.						
DESIGNER: VERMONT AGENCY OF TRANSPORTATION						
CHECKED	10/96	CSD	WORK ORDER NO.	15713	DRAWING NO.	10-21
DRAWN	9/96	CSD				