

SHIP		BILL OF MATERIAL		JOB NO.	DRAWING NO.	REV.	
G12A		GIRDER		4-8	52-8	△	
MARK	NO.	MARK	SHAPE	LENGTH	WT.	ITEM NO.	REMARKS
1	WPI	R 9/16 x 5/8	41 0	10.5714	1/4	A012	CVN
1	tf1	R 1/8 x 16	40 11 1/2	10.212	1/8	B511	CVN
1	bf1	R 3/8 x 16	20 0 1/2	10.212	1/4	956	
1	bf2	R 1/8 x 16	20 11 1/2	10.212	1/8	1286	
2	sp1	R 2 x 5 1/2	2 2	10.374	1/4	380	CVN
1	sp2	R 1/2 x 16	2 5	10.374	1/8	66	CVN
2	sp3	R 3/8 x 7	2 5	10.374	1/8	78	CVN
1	sp4	R 4 x 16	1 2 3/8	10.374	1/8	16	
1	sp5	R 3/8 x 16	2 11	10.374	1/8	99	CVN
2	sp6	R 1/2 x 7	2 11	10.374	1/8	96	CVN
1	bs1	BAR 7/8 x 1 3/8	4 8	10.374	1/4	97	MIF
1	bs7	BAR 7/8 x 1 3/8	4 8	10.374	1/4	97	MIF
1	sf12	BAR 5 x 3/8	2 6	10.374	1/4	27	ALSO QTS 1M+49
1	fb1R	R 1/4 x 2 3/8	0 10 1/2	10.374	1/4	2	

IT. NO.	506.91	BR. NO.	PROJ. NO.	F020-1(10)	
FOR APPROVAL		FOR FILES & FIELD			
STEEL: ASTM <input type="checkbox"/> A36 <input type="checkbox"/> A572 GR <input checked="" type="checkbox"/> A588 IGR <input type="checkbox"/> Unless Noted					
WELDING ELECTRODE: <input type="checkbox"/> E70 <input checked="" type="checkbox"/> See Welding Proc. <input type="checkbox"/> None					
SHOP CONN: <input type="checkbox"/> Bolted <input checked="" type="checkbox"/> Welded <input type="checkbox"/> None					
FIELD CONN: <input checked="" type="checkbox"/> Bolted <input checked="" type="checkbox"/> Welded <input type="checkbox"/> None					
HOLES: <input type="checkbox"/> 13/16 <input checked="" type="checkbox"/> 15/16 <input type="checkbox"/> Unless Noted <input type="checkbox"/> None					
PAINT: <input type="checkbox"/> None <input type="checkbox"/> Shopcoat <input type="checkbox"/> Galv. After Fab. <input type="checkbox"/> As Noted					
SPECIAL PAINT: <input type="checkbox"/> None <input checked="" type="checkbox"/> SSPC-SP6					
SPECIAL CLEANING: <input checked="" type="checkbox"/> Blast Clean <input type="checkbox"/> None					
GIRDER G12A					
APPROVED: 5-8-84		Barcroft & Martin Inc			
PRINT DIST.		South Portland, Maine 04106			
7	3-26-84	APP.			
8	5-10-84	FAB.			
		F&F.	JOB: U.S. 4 OVER TWO-WAY RAMP		
7	4-6-84	APP	WEST RUTLAND, RUTLAND, VERMONT		
CUSTOMER: M&J CONSTRUCTION CO.					
DESIGNER: STATE OF VERMONT, AGENCY OF TRANSP.					
REV. △		ORDER NO.	JOB NO.	DRAWING NO.	REV.
CHECKED	3-20-84 RW			4-8	52-8
DRAWN	2-27-84 ELC				△

ONE - GIRDER - G12A
 FOR GIRDER STANDARD DETAILS SEE DWG. 52-2
 FOR WEB R CUTTING SK. & FLG. R ASSY SEE DWG. 52-1
 FOR SHOP ASSEMBLY DIAGRAM SEE DWG. 52-1

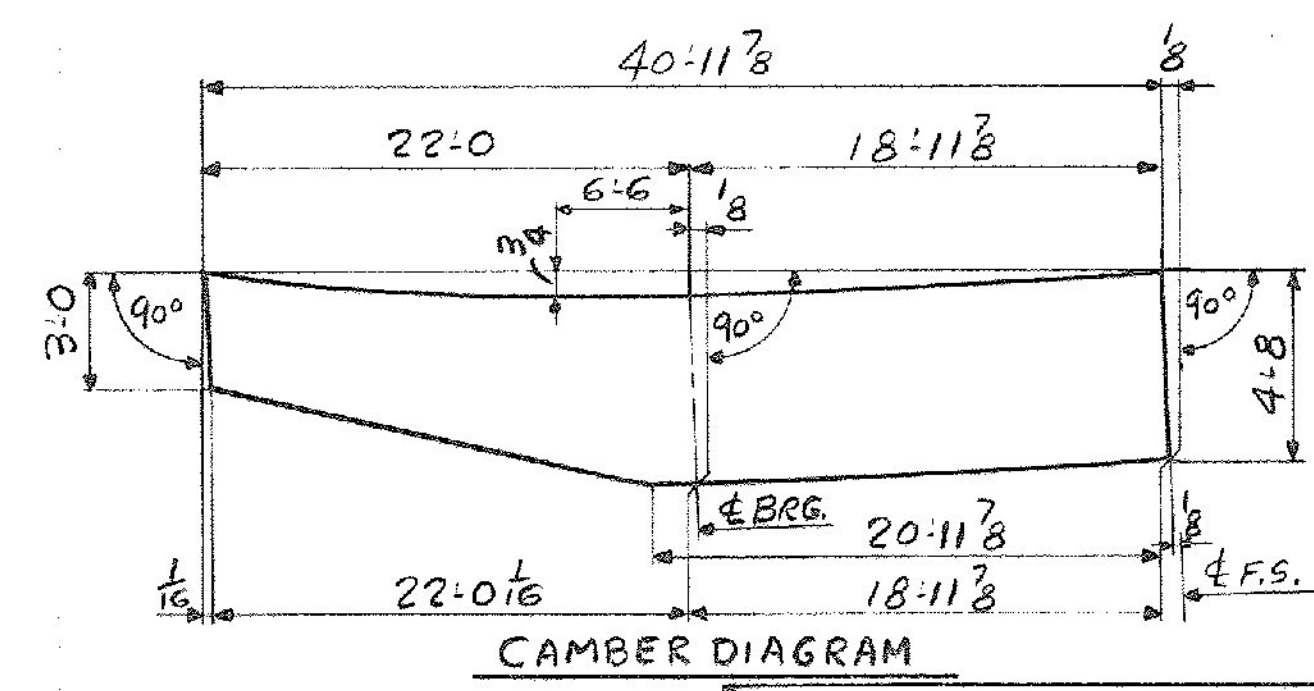

ALL CONNECTIONS DETAILED ON THIS DRAWING REPRESENT BARCROFT & MARTIN INC STANDARDS. IN APPROVING THIS DRAWING FOR FABRICATION, THE ARCHITECT AND/OR ENGINEER ASSUMES THE RESPONSIBILITY FOR THE STRUCTURAL INTEGRITY OF ALL CONNECTIONS SHOWN.

DIM. (X)
4:6
8:6
12:6
16:6
20:6
24:6
28:6
32:6
36:6
38:0