

DIM. (X)	
2'-G	38'-G
6'-G	42'-G
10'-G	46'-G
14'-G	50'-G
18'-G	54'-G
22'-G	58'-G
26'-G	62'-G
30'-G	66'-G
34'-G	70'-G

SHOP NOTE - W
 WELD SIZE SHOWN SHALL BE INCREASED BY THE AMOUNT OF GAP, IF ANY, BETWEEN EDGE OF CONN. PLATE AND TOP OF BOTTOM FLANGE PL. (MAX. GAP = 1/8").

ONE - GIRDER - HG4B
 FOR GIRDER STANDARD DETAILS SEE DWG. 52-3
 FOR WEB & CUTTING SK. & FLG. ASSY SEE DWG. 52-2
 FOR SHOP ASSEMBLY DIAGRAM SEE DWG. 52-1

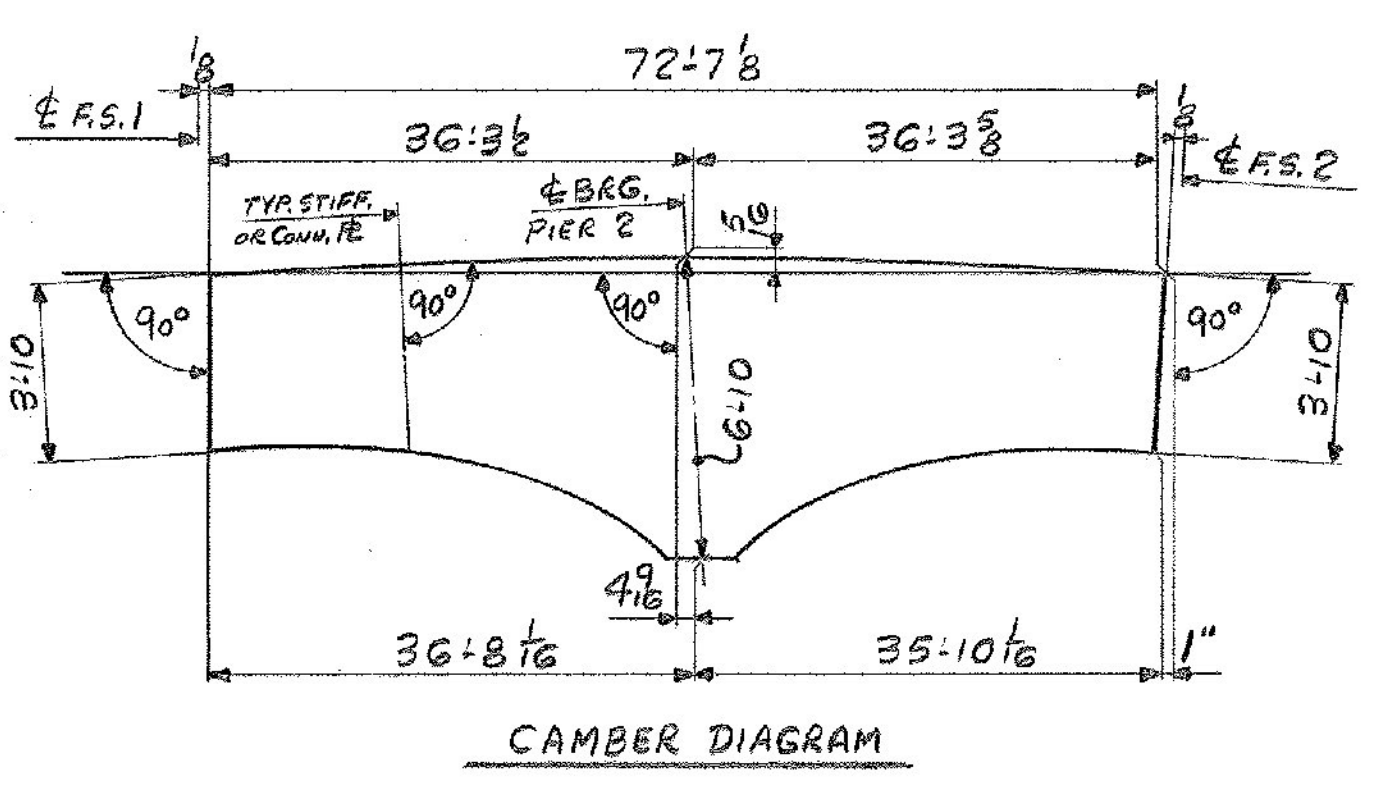

SHIP		BILL OF MATERIAL				JOB NO.	DRAWING NO.	REV.
HG4B		GIRDER				4-7	52-15	△
MARK	NO.	MARK	SHAPE	LENGTH	WT.	ITEM NO.	WT.	REMARKS
1	wpl		PL 5/8 x 82	72 7/8	24 1/2	1/C	8675	CVN
1	tf1		PL 1/4 x 16	72 7/8	10 7/8	1/T	4940	↑
1	bf1		PL 1/4 x 16	35 10 1/16	10 3/8	1/N	2443	BENT
1	bf2		PL 1/4 x 16	2 0 5/8	10 10/8	1/Q	138	
1	bf3		PL 1/4 x 16	35 0 3/4	10 35/8	1/O	2386	BENT
2	sp1		PL 1/2 x 42	1 7	10 1/2	2/A	226	
2	sp2		PL 1/2 x 16	2 4	10 1/2	2/B	159	
4	sp3		PL 1/2 x 7	2 4	10 1/2	2/C	139	CVN
1	sp4		PL 3/8 x 16	1 1 1/2	10 1/2	2/D	24	
1	sp5		PL 1/4 x 16	1 1 1/2	10 1/2	2/E	16	
2	sf1		PL 1/2 x 7	6 3 3/8	10 1/2	2/O	261	1R, 1L
2	sf2		PL 1/2 x 7	6 5 1/8	10 1/2	2/O	269	1R, 1L
1	bs2		PL 1/2 x 7	6 10	10 1/2	2/G	142	MIE
1	bs4		PL 1/2 x 7	6 10	10 1/2	2/G	142	MIE
1	sf9		PL 1/2 x 7	3 11 1/8	10 1/2	2/L	47	
1	sf3		PL 1/2 x 7	3 7 1/8	10 1/2	2/J	43	
2	fb2R		PL 1/4 x 34	0 10 1/8	CR/BS	2/P	5	1R, 1L
								20,053 #
1	SPI		SOLE PLATE					DET. ON DWG. 51-1 (Job. No. 4-11)

IT. NO. 506.91 BR. NO. 4 PROJ. NO. F020-1(10)

FOR APPROVAL | **FOR FILES & FIELD**

STEEL: ASTM. A36 A72 GR A588 GR Unless Noted

WELDING ELECTRODE: E70 See Welding Proc. None

SHOP CONN: Bolted Welded None

FIELD CONN: Bolted Welded None

HOLE: 13/16 15/16 Unless Noted None

PAINT: None Shopcoat Galv. After Fab. As Noted

SPECIAL PAINT: _____

SPECIAL CLEANING: Blast Clean None SSPC-SP6

GIRDER - HG4B

APPROVED: 5-17-89
 PRINT DIST. 4-11-89 APP. 8 6-22-89 FAB. NR F&F.

Bancroft & Martin Inc.
 South Portland, Maine 04106

JOB: T.H. 22 OVER U.S. 4 E.B. & W.B. RUTLAND, VERMONT

CUSTOMER: M & J CONSTRUCTION Co.
 DESIGNER: STATE OF VERMONT, AGENCY OF TRANSP.

REV.	DATE	BY	ORDER NO.	JOB NO.	DRAWING NO.	REV.
7	4-11-89	GK		4-7	52-15	△
8	6-22-89	ELC				