

SHIP		BILL OF MATERIAL				JOB NO.	DRAWING NO.	REV.
GIA ONE		GIRDER				4-46	52-3	△
MARK	NO.	MARK	SHAPE	LENGTH	WT.	ITEM NO.	WT.	REMARKS
	1	wpl	PL 1/2 x 388	77 0 1/2	3 1/2 x 77.3	A4975		CVN
	1	tf1	PL 1/8 x 16	77 0 1/2	1 6 x 77.3	E4718		CVN
	1	bfl	PL 1/8 x 16	76 10 1/2	1 6 x 77.1	F4708		CVN
	1	bs1	PL 3/4 x 8	3 2	1 1/2 x 3.2	P65		
	1	bs2	PL 3/4 x 8	3 2	1 1/2 x 3.2	P65		
	1	bs3	PL 3/4 x 8	3 2	1 1/2 x 3.2	P65		
	1	bs6	PL 3/4 x 8	3 2	1 1/2 x 3.2	P65		
	2	sf2	PL 1/2 x 8	2 11	3/8 x 21.0	G79		
	1	sf7	PL 1/2 x 8	2 11	3/8 x 21.0	G40		
	1	sf8	PL 1/2 x 8	2 11	3/8 x 21.0	G40		
	1	fb1	PL 4 x 38	0 10 3/8	1 1/2 x 10.375	R2		
* PAY WEIGHT								
	1		PL 1/8 x 16	12 0			735	
	1		PL 1/8 x 16	63 0 1/2			3093	
	1		PL 1/8 x 16	22 0 1/4			749	
	1		PL 1/8 x 16	54 10 1/2			1612	
							1319 0 #	PAY WEIGHT

DIMENSION (X)		
1'-6	27'-6	55'-6
4'-6	31'-6	59'-6
7'-6	35'-6	63'-6
11'-6	39'-6	67'-6
15'-3	43'-6	71'-6
19'-6	47'-6	75'-6
23'-6	51'-6	

**ONE-GIRDER-GIA**  
 FOR GIRDER STANDARD DETAILS SEE DWG. 52-2.  
 FOR WEB & FLG. R CUTTING & ASSEMBLY SEE DWG. 52-1.

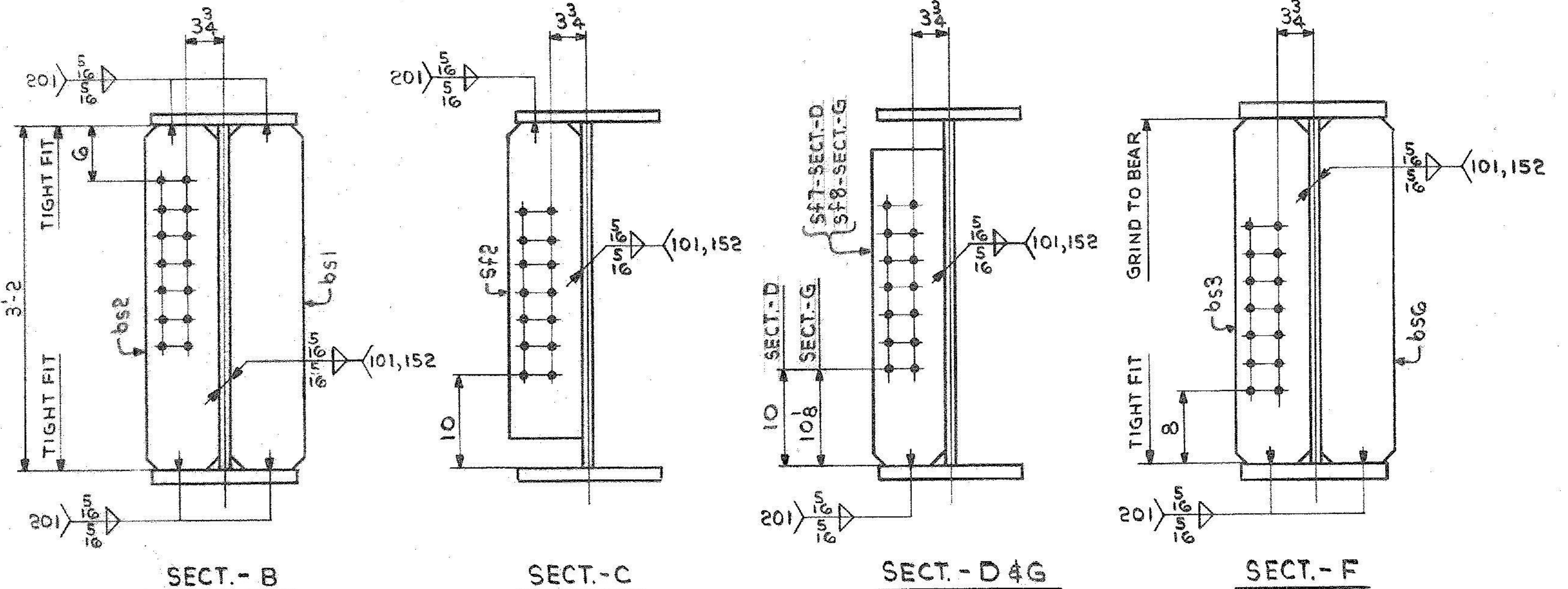
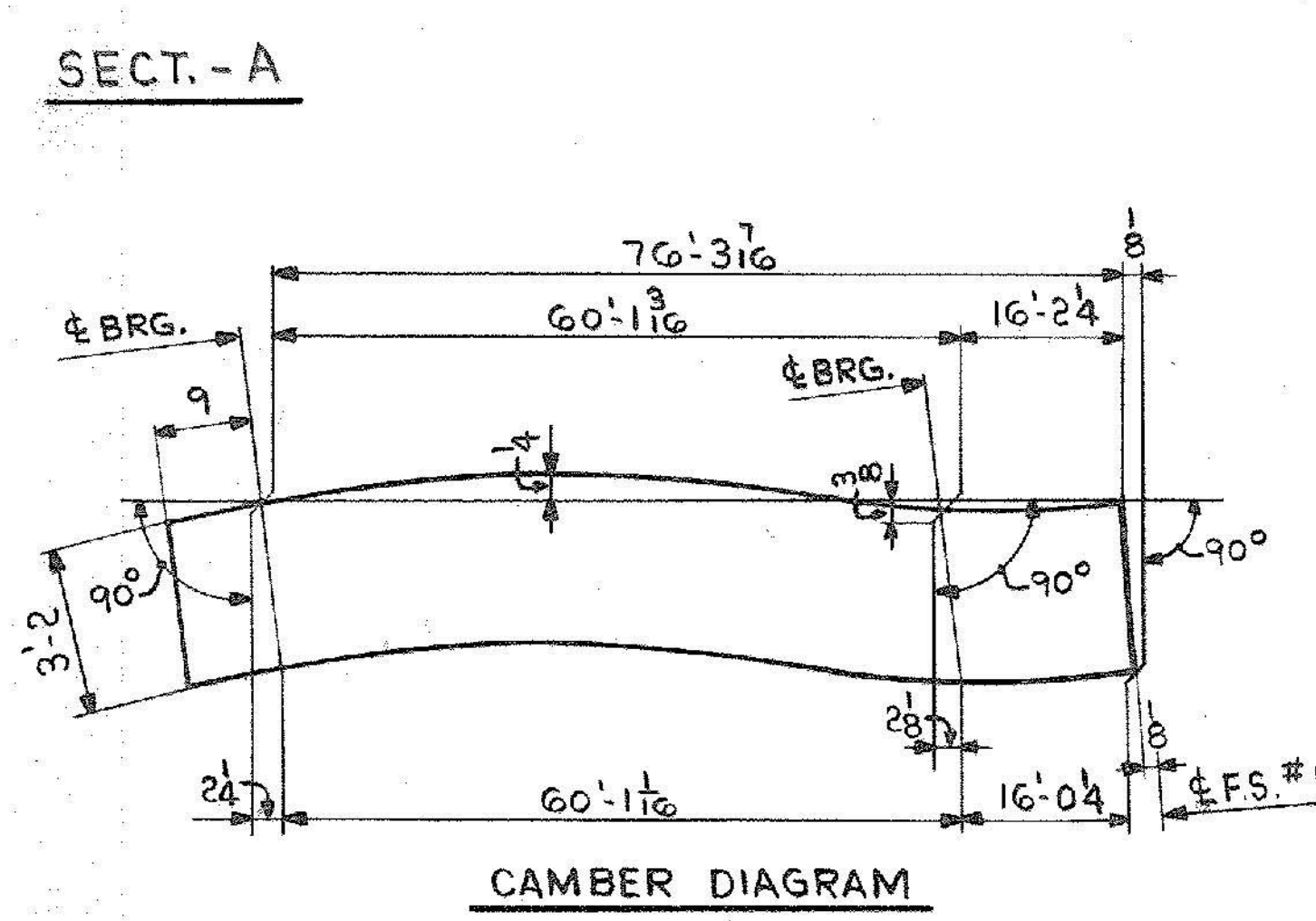
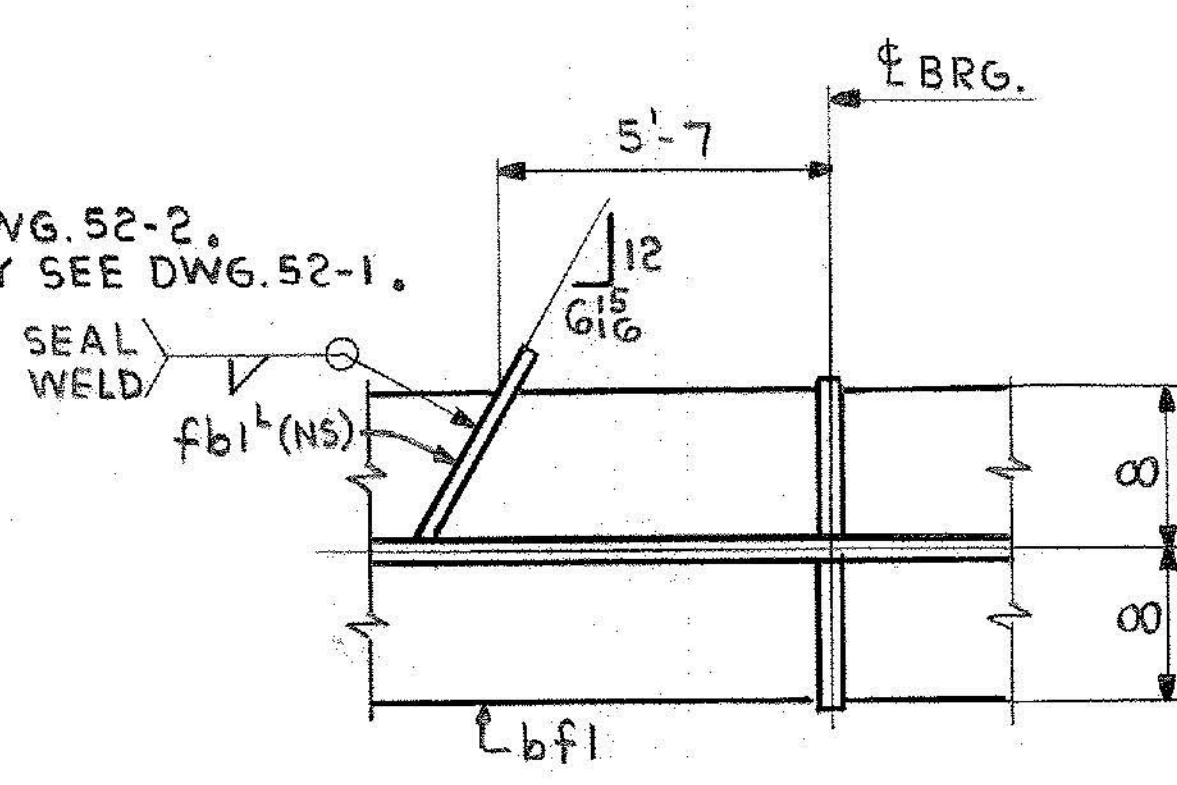

IT. NO. 506.91 BR. NO. 5 PROJ. NO. F-EGG-F-020-1(10)

**FOR APPROVAL FOR FILES & FIELD**

STEEL: ASTM  A36  A572 GR  A588 GR  Unless Noted

WELDING ELECTRODE:  E70  See Welding Proc.  None

SHOP CONN:  Bolted  Welded  None

FIELD CONN:  Bolted  Welded  None

HOLES:  13/16  15/16  Unless Noted  None

PAINT:  None  Shopcoat  Galv. After Fab.  As Noted

SPECIAL PAINT: NONE

SPECIAL CLEANING:  Blast Clean  None  SSPC-SP6

**GIRDER-GIA**

APPROVED: 2-1-85  
 PRINT DIST.  
 7 12-27-84 APP.  
 8 2-11-85 FAB.  
 ORIG. 11-19-85 V.A.T.

**Bancroft & Martin Inc.**  
 South Portland, Maine 04106

JOB: U.S. ROUTE 4 E.B. OVER DORR DRIVE  
 RUTLAND, VERMONT

CUSTOMER: MASKELL FENCE CO.  
 DESIGNER: STATE OF VERMONT, AGENCY OF TRANS.

REV. △  
 CHECKED: RW 12-21-84  
 DRAWN: DW 11-20-84

ORDER NO. 4-46 JOB NO. 52-3 DRAWING NO. REV. △