

ONE-GIRDER-GIC
 FOR GIRDER STANDARD DETAILS SEE DWG. 52-2.
 FOR WEB & FLG. R CUTTING & ASSEMBLY SEE DWG. 52-1.

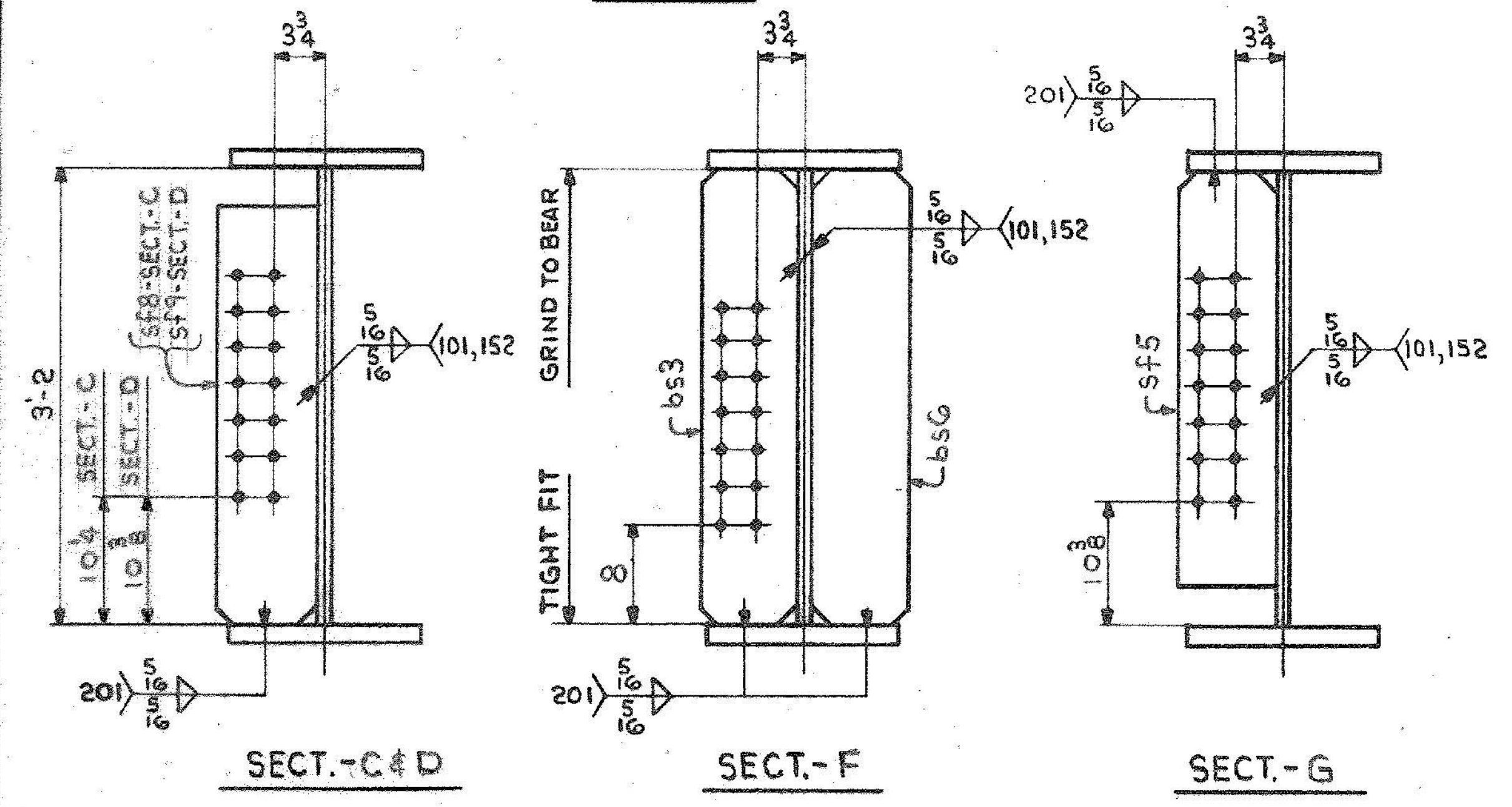

DIM. (X)	
1'-4 1/8	45'-4 1/8
5'-4 1/8	49'-4 1/8
9'-4 1/8	53'-4 1/8
13'-4 1/8	57'-4 1/8
17'-4 1/8	61'-4 1/8
21'-4 1/8	65'-4 1/8
25'-4 1/8	69'-4 1/8
29'-4 1/8	73'-4 1/8
33'-4 1/8	77'-4 1/8
37'-4 1/8	81'-4 1/8
41'-4 1/8	

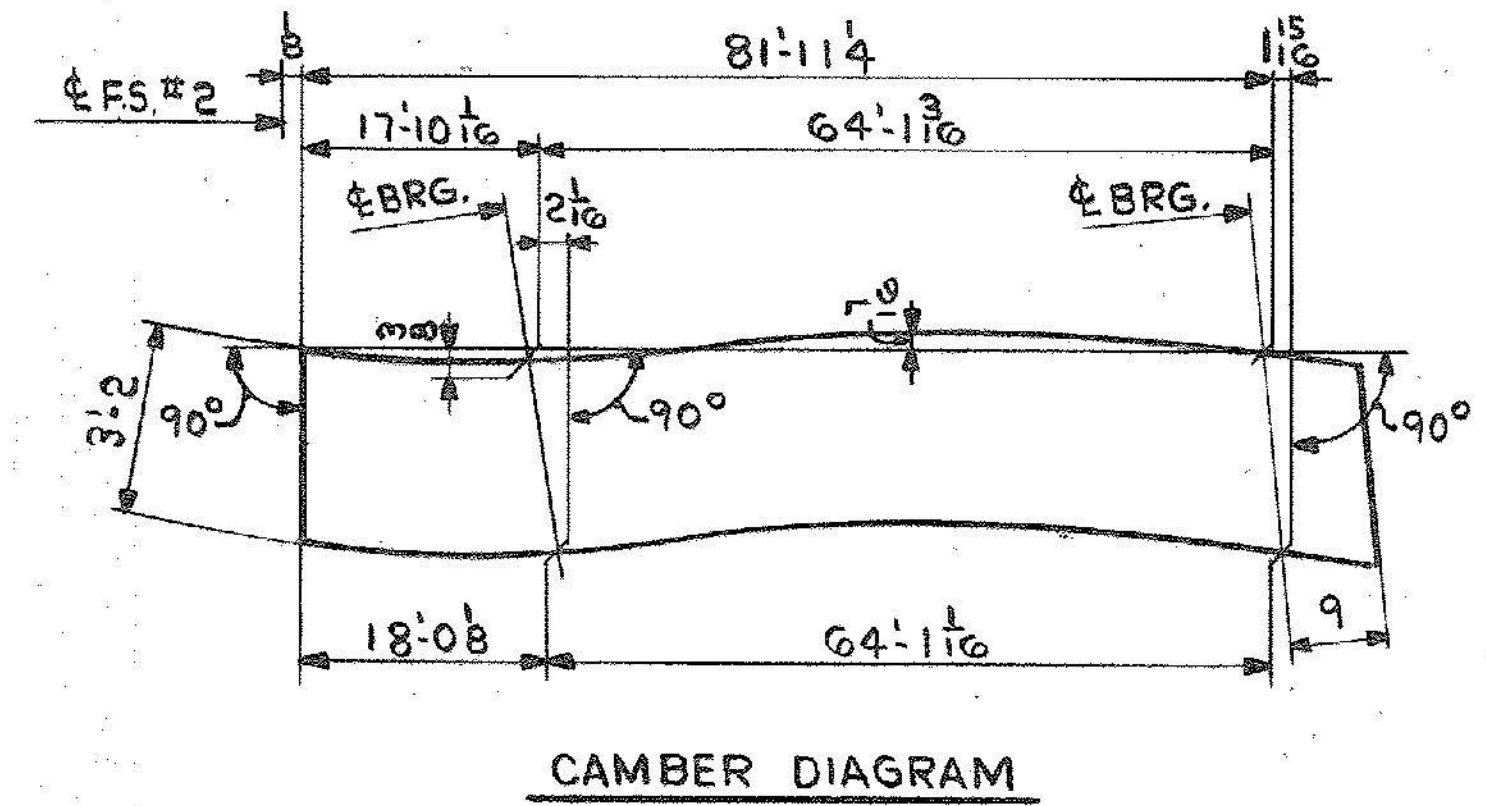

SHIP		BILL OF MATERIAL		JOB NO.		DRAWING NO.		REV.
				4-45		52-9		△
MARK	NO.	MARK	SHAPE	LENGTH	WT.	ITEM NO.	WT.	REMARKS
GIC	ONE		GIRDER					
	1	wf1	R 1/2 x 38 13/16	82 10 3/16	10 39 1/2	1	5351	CVN
	1	tf1	R 1 3/8 x 16	82 8 4	16 82 11	1	5346	CVN (11733) *
	1	bf1	R 1 3/8 x 16	82 10 3/16	16 82 11	1	5350	CVN *
	1	bs3	R 3/4 x 8	3 2	10 8 20 10	2	A	65
	1	bs6	R 3/4 x 8	3 2	10 8 20 10	2	A	65
	2	sf5	R 1/2 x 8	2 11	23 6 21 0	2	B	79
	1	sf8	R 1/2 x 8	2 11	23 6 21 0	2	B	40
	1	sf9	R 1/2 x 8	2 11	23 6 21 0	2	B	40
	1	p1	R 4 x 8 3/4	2 10 4	4 0 7 2	2	I	21 BENT
	2	fb2 ^t	R 4 x 3 1/2	0 10 8	4 4 3 4 11	2	H	5
* PAY WEIGHT								
	2		R 1 3/8 x 16	12 0				1552
	1		R 1 3/8 x 16	70 8 4				3267
	1		R 1 3/8 x 16	70 10 3/16				3375
13960 # PAY WEIGHT								
16368 # SHIPPING WEIGHT								

IT. NO. 506.91 BR. NO. 5 PROJ. NO. F-EGG-F-020-1(10)

FOR APPROVAL **FOR FILES & FIELD**

STEEL: ASTM A36 A572 GR1 A588 GR [Unless Noted]

WELDING ELECTRODE: E70 See Welding Proc. None

SHOP CONN: Bolted Welded None

FIELD CONN: Bolted Welded None

HOLES: 13/16 15/16 [Unless Noted] None

PAINT: None Shopcoat Galv. After Fab. As Noted

SPECIAL PAINT: NONE

SPECIAL CLEANING: Blast Clean None SSPC-SP6

GIRDER-GIC

APPROVED: 2-1-85

PRINT DIST. 7 12-27-84 APP. B 2-6-85 FAB. 0216 3-26-86 VAT

Bancroft & Martin Inc.
 South Portland, Maine 04106

JOB: U.S. ROUTE 4 W.B. OVER DORR DRIVE
 RUTLAND, VERMONT

CUSTOMER: MASKELL FENCE CO.
 DESIGNER: STATE OF VERMONT, AGENCY OF TRANS.

REV. △			ORDER NO.	JOB NO.	DRAWING NO.	REV.
CHECKED	RW	1/22-84		4-45	52-9	△
DRAWN	DW	11-19-84				