

STOP SIGN SHALL BE PLACED ON DRIVERS RIGHT, MAINTAINING MAXIMUM VISIBILITY. CLEARANCE SHALL BE A MINIMUM OF 6' AND A MAXIMUM OF 50' FROM SHOULDER POINT OF INTERSECTING ROADWAY AND DOES NOT HAVE TO BE ADJACENT TO THE STOP BAR.

LEGAL LOAD LIMIT AND STOP SIGNS AT INTERSECTIONS

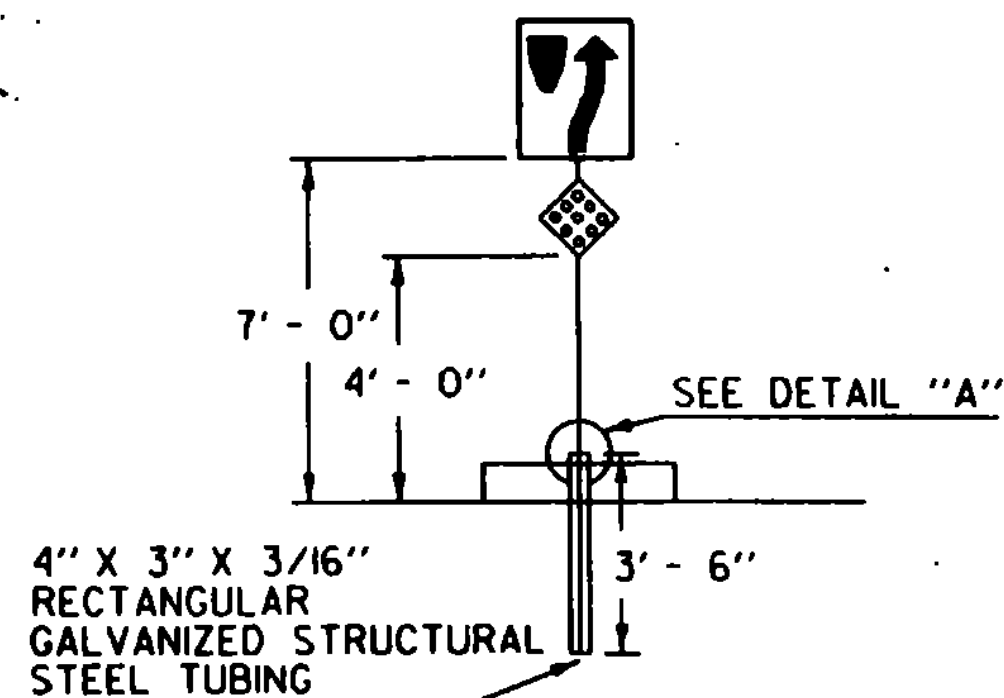

TO INSURE A TIGHT CONNECTION 1/4" GALVANIZED WASHERS SHALL BE USED AS SPACERS.

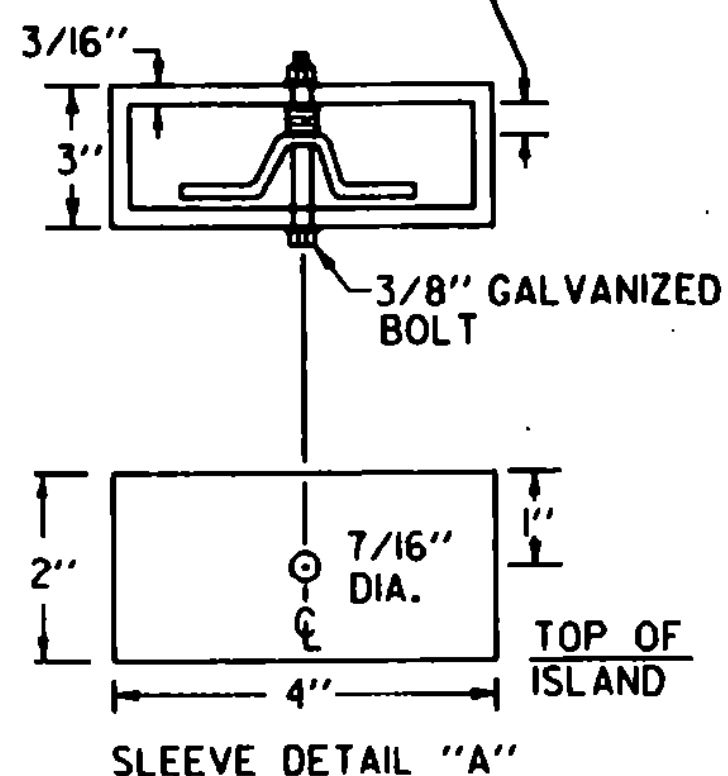

WARNING SIGNS ON ISLAND IN THE LINE OF TRAFFIC

INCREASE VERTICAL CLEARANCE TO 7' IN AREAS OF FREQUENT ROADSIDE PARKING OR PEDESTRIAN ACTIVITY

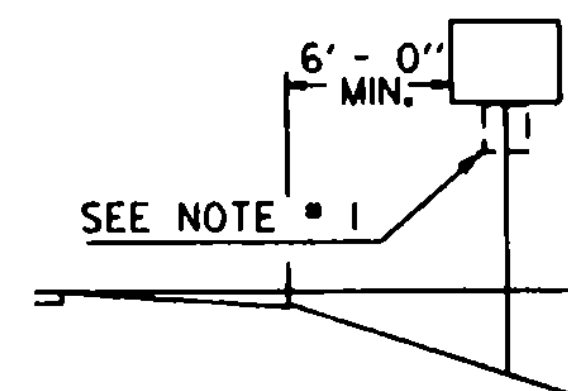
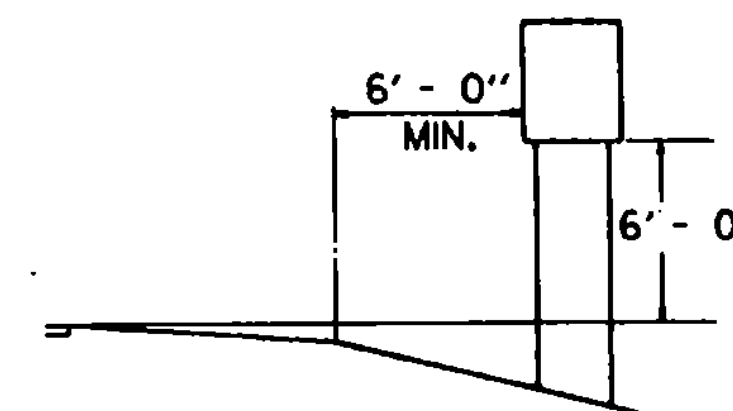

RURAL

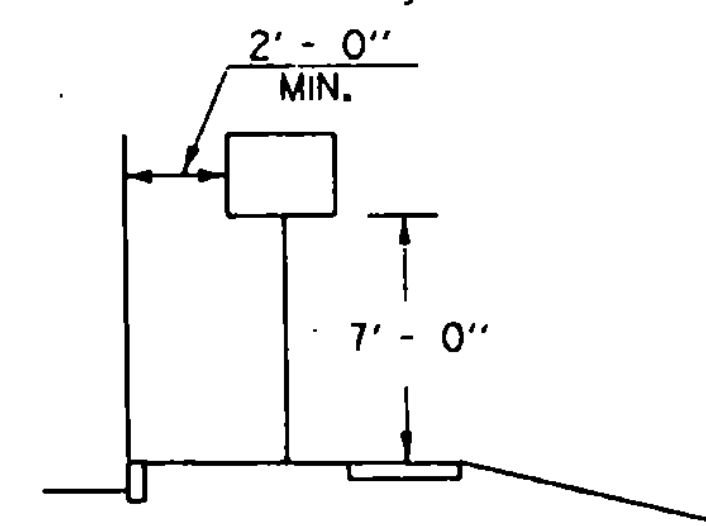
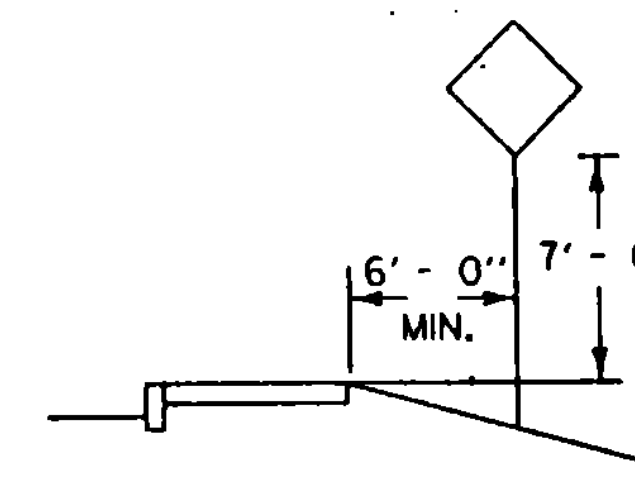

IF SUFFICIENT CLEARANCE IS NOT AVAILABLE BETWEEN CURB AND SIDEWALK MOUNT SIGN BEHIND SIDEWALK AS SHOWN AT TOP. CHECK FOR ADEQUATE R.O.W..

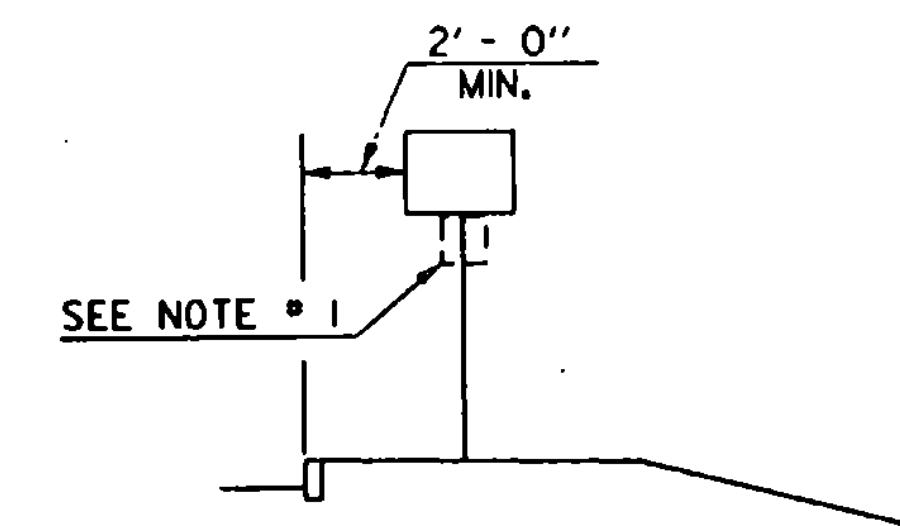

URBAN

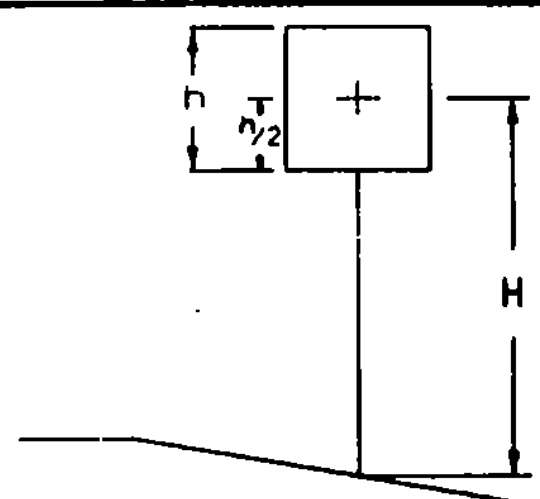

SIGN AREA (FT²) X H (FT) = (SV (SELECTION VALUE))

POST SELECTION CHART

POST REFERENCE: PROPER MOUNTING OF SIGNS ON APPROPRIATE SIZE POSTS IS COVERED IN DETAIL ON STANDARD E - 160 FOR FLANGED CHANNEL POSTS AND STANDARD E - 162 FOR TUBULAR ALUMINUM POSTS. FOR CONVENIENCE POST SELECTION TABLES ARE ALSO SHOWN AT LEFT.

WHEN SV VALUES EXCEED THOSE SHOWN ON THE TABLES THE TOTAL SV MAY BE DIVIDED BY TWO AND THAT VALUE USED TO SELECT AN APPROPRIATE SIZE AND MATERIAL FOR A TWO POST INSTALLATION.

HOWEVER, TWO POST ASSEMBLIES WHICH REQUIRE UNUSUALLY LONG POSTS, EITHER BECAUSE OF STEEP SLOPES OR TOTAL HEIGHT OF THE SIGN OR SIGNS DISPLAYED, SHOULD ALWAYS BE MOUNTED ON ALUMINUM TUBES TO TAKE ADVANTAGE OF THE GREATER EMBEDMENT DEPTH.

POST SIZE	SV
2 LB./FT. (ONE POST INSTALLATION)	32
2 LB./FT. (TWO POST INSTALLATION)	62
2.5 LB./FT.	77
3 LB./FT.	107

POST SIZE	SV (FT.)
3" DIA.	257
3" SQUARE TUBE *	350
4" DIA.	477

SINGLE 2 LB. AND 2.5 LB. PER FOOT POSTS SHALL ONLY BE USED IN URBAN AREAS.

* USE ON SINGLE POST INSTALLATIONS ONLY

FLANGED CHANNEL STEEL SIGN POSTS

TUBULAR ALUMINUM SIGN POSTS

NOTES:

1. IN BOTH RURAL AND URBAN LOCATIONS, IF A SECONDARY SIGN IS MOUNTED BELOW ANOTHER SIGN, THE MINIMUM CLEARANCE MAY BE REDUCED BY ONE FOOT.
2. IN RURAL AREAS WITH NO OR MINIMAL SHOULDER, THE LATERAL CLEARANCE TO THE EDGE OF A SIGN SHOULD BE A MINIMUM OF 12' FROM THE EDGE OF THE TRAVELED WAY.
3. ALSO SEE OTHER STANDARD SHEETS FOR MOUNTING CLEARANCE AND SPACING OF DESTINATION AND ROUTE MARKER ASSEMBLIES AND TOWN LINE SIGNS.

REVISIONS AND CORRECTIONS

APPROVED

JAN. 23, 1989

DATE

David R. Kelley
CHIEF ENGINEER

Arthur J. Lewis
DIRECTOR OF PLANNING AND PRE-CONSTRUCTION

Stanley B. MacArthur
TRAFFIC AND SAFETY ENGINEER

**STANDARD SIGN PLACEMENT
CONVENTIONAL ROAD**

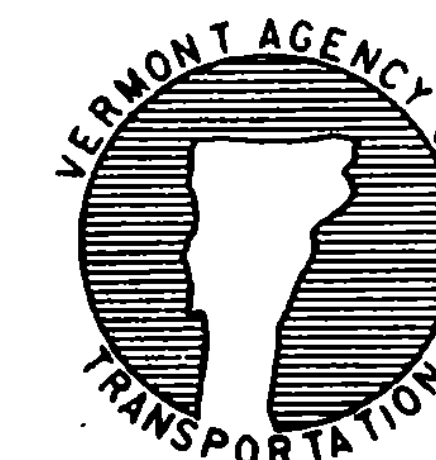

**STANDARD
E-121**

APPROVED FOR THIS PROJECT AND/OR DESIGN IMPLEMENTATION. FHWA FINAL APPROVAL PENDING.