

DELINEATOR TYPICAL
 DELINEATORS SHALL BE REFLECTORIZED WHITE IN COLOR. THEY SHALL HAVE A MINIMUM OF 7 SQUARE INCHES. THEY MAY BE ROUND, SQUARE, OR OBLONG.

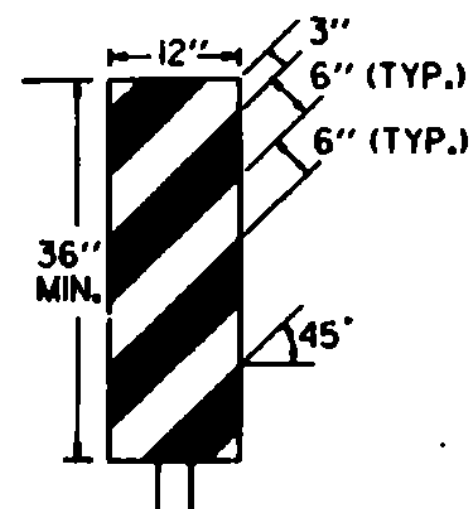

OBJECT MARKER TYPICAL

OBJECTS ADJACENT TO THE ROADWAY SHALL REQUIRE AN OBJECT MARKER TO MARK THE OBSTRUCTION. IN SOME CASES THERE MAY NOT BE A PHYSICAL OBJECT INVOLVED BUT OTHER ROADSIDE CONDITIONS SUCH AS NARROW SHOULDER DROP-OFFS, GORES, D.I. EXCAVATIONS, OR ABRUPT CHANGES IN THE ROADWAY ALIGNMENT MAY MAKE IT UNDESIRABLE FOR A DRIVER TO LEAVE THE ROADWAY. THE INSIDE EDGE OF THE OBJECT MARKER SHALL BE IN LINE WITH THE INNER EDGE OF THE OBSTRUCTION, WHENEVER POSSIBLE.
 OBJECT MARKERS SHALL HAVE ALTERNATING REFLECTORIZED BLACK STRIPES, (SLOPING DOWNWARD IN THE DIRECTION TRAFFIC IS TO PASS).

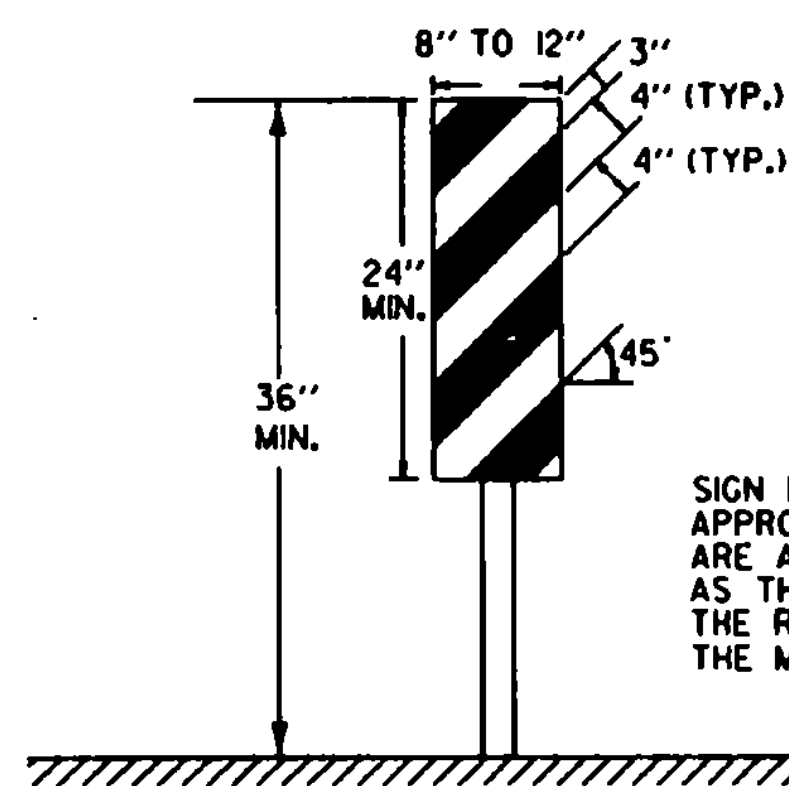

VERTICAL PANEL

VERTICAL PANELS SHALL HAVE ALTERNATING ORANGE AND WHITE REFLECTORIZED STRIPES (SLOPING DOWNWARD IN THE DIRECTION TRAFFIC IS TO PASS). THESE DEVICES MAY BE USED FOR TRAFFIC SEPARATION OR SHOULDER BARRICADE WHERE SPACE IS AT A MINIMUM.

DELINEATOR AND OBJECT MARKER DETAILS FOR CONSTRUCTION AREAS WHERE TRAFFIC IS MAINTAINED

DETOUR DESIGN SPEED MPH	RADIUS FT	DELINEATOR SPACING - "S" FT
25	150	30
30	250	40
40	450	60
50	760	75

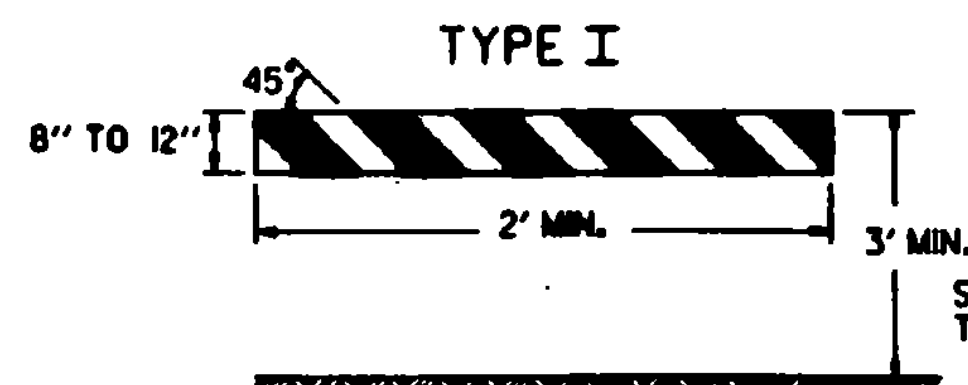

STRIPING IS SHOWN WITH TRAFFIC PASSING TO THE RIGHT.

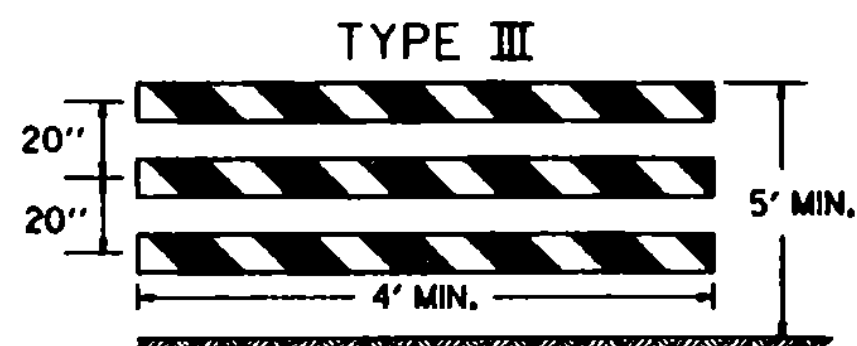
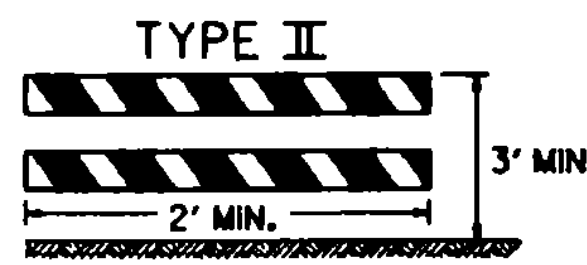

A TYPE III (MODIFIED) BARRICADE SHALL CONSIST OF TYPE II RAILS MOUNTED ON A BREAKAWAY BARRICADE AS SHOWN ON STANDARD SHEET E-107A.

BARRICADE CHARACTERISTICS			
	I	II	III
WIDTH OF RAIL	8" MIN	8" MIN	8" MIN
LENGTH OF RAIL	12" MAX	12" MAX	12" MAX
WIDTH OF STRIPES*	6"	6"	6"
HEIGHT	3' MIN.	3' MIN.	5' MIN.
TYPE OF FRAME	LIGHT 'A' FRAME NO STAY BRACE	LIGHT 'A' FRAME NO STAY BRACE	SEE E-107A
FLEXIBILITY	PORTABLE	PORTABLE	PORTABLE
ANGLE OF STRIPE	45°	45°	45°
COLOR OF STRIPES	ORANGE AND WHITE	ORANGE AND WHITE	ORANGE AND WHITE

* FOR RAILS LESS THAN 3 FEET LONG 4" WIDE STRIPES SHALL BE USED.

BARRIER CHARACTERISTICS

- SIGNS AND DELINEATION SHOWN FOR ONE DIRECTION OF TRAFFIC ONLY.
- CONTRACTOR IS RESPONSIBLE FOR PAVEMENT MARKING AND SHALL REMOVE ANY CONFLICTING OR CONFUSING EXISTING MARKINGS.
- ADDITIONAL SIGNING MAY BE REQUIRED AT THE DISCRETION OF THE ENGINEER.
- UNPAVED DETOURS REQUIRE PAVEMENT MARKINGS FOR TRANSITIONS ON EXISTING PAVEMENT.

BARRICADES

APPLICATION NOTES

TYPE I BARRICADES ARE TO BE USED ON CONVENTIONAL ROADS OR URBAN STREETS AND ARTERIALS TO MARK A SPECIFIC HAZARD.

TYPE II BARRICADES ARE TO BE USED ON EXPRESSWAYS AND FREEWAYS, SERVING THE SAME FUNCTIONS AS THE TYPE I BARRICADES.

TYPE III BARRICADES (SEE STANDARD E-107A) SHALL ONLY BE USED WHEN A ROAD SECTION IS CLOSED TO TRAFFIC AND ARE TO BE ERECTED AT THE POINT OF CLOSURE.

MATERIALS

THE BARRICADES SHOWN ON THIS SHEET NORMALLY WILL BE OF LIGHTWEIGHT MATERIAL. IF WOOD IS USED THE FOLLOWING CONDITIONS SHALL APPLY:

I. WOODEN BARRICADES (TYPES I AND II)

- SHALL NOT BE USED TO CHANNELIZE OR DELINEATE WORK AREAS WITHIN THE CLEAR ZONE OF ANY HIGHWAY WHERE OPERATING SPEEDS IN EXCESS OF 20 MILES PER HOUR ARE EXPECTED UNLESS INSTALLED FOR PEDESTRIAN CONTROL BEHIND APPROVED POSITIVE BARRIERS.
 - MAY BE USED IF OPERATING SPEEDS OF 20 M.P.H. OR LESS ARE EXPECTED.
2. TYPE III WOODEN BARRICADES SHALL NOT BE USED.

DESIGN

THE DESIGN OF THE BARRICADES SHALL CONFORM WITH THE DETAILS SHOWN ON THIS SHEET AND THE MARKINGS ON THE BARRICADES SHALL BE ALTERNATE ORANGE AND WHITE STRIPES, (SLOPING DOWNWARD AT AN ANGLE OF 45° IN THE DIRECTION TRAFFIC IS TO PASS)

COLORS

THE BARRICADE PANELS SHOWN ON THIS SHEET SHALL HAVE ALTERNATING REFLECTORIZED WHITE AND ORANGE STRIPES. THE ORANGE SHALL CONFORM WITH THE STANDARD COLORS ADOPTED BY THE AMERICAN ASSOCIATION OF STATE HIGHWAY AND TRANSPORTATION OFFICIALS AND APPROVED BY THE U.S. DEPARTMENT OF TRANSPORTATION FEDERAL HIGHWAY ADMINISTRATION. THE BARRICADE COMPONENTS SHALL BE WHITE UNLESS UNPAINTED METAL OR ALUMINUM IS USED.

REFLECTORIZATION

THE BARRICADE PANELS SHALL BE REFLECTORIZED WITH REFLECTIVE SHEETING.

LOCATION

THE BARRICADES SHOWN ON THIS SHEET WILL BE LOCATED BY THE ENGINEER IN THE FIELD OR AS SHOWN ON THE PLANS. THE LOCATION OF THE BARRICADES SHALL FOLLOW THE PROCEDURES SET FORTH IN "THE MANUAL ON UNIFORM TRAFFIC CONTROL DEVICES", OR AS OTHERWISE NOTED.

MAINTENANCE

BARRICADES SHALL BE MAINTAINED IN CLEAN CONDITION, SATISFACTORY TO THE ENGINEER. THEY SHALL BE COMPLETELY VISIBLE TO APPROACHING TRAFFIC AT ALL TIMES. DAMAGED, DEFACED, OR DIRTY BARRICADES SHALL BE REPAIRED, CLEANED, OR REPLACED AS ORDERED BY THE ENGINEER.

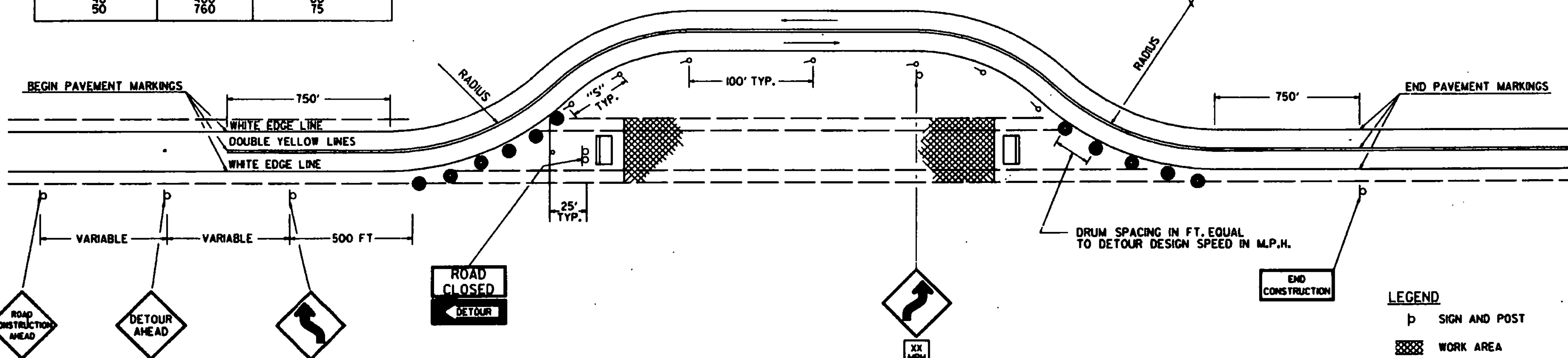

ALL SIGN PLACEMENT DISTANCES ARE DESIRABLE SPECIFICATIONS. FIELD CONDITIONS SHALL CONTROL THE ACTUAL PLACEMENT. PROJECT CONSTRUCTION APPROACH SIGNING PLACEMENT SHALL TAKE INTO CONSIDERATION SPACING FOR THE DETOUR SIGN LAYOUT REQUIREMENTS.

TRAFFIC CONTROL PLAN TWO LANE HIGHWAY PAVED DETOUR

SEE VARIOUS STANDARD SHEETS FOR SIGN DETAIL AND MATERIAL REQUIREMENTS

REVISIONS AND CORRECTIONS
 APRIL 29, 1988 - FHWA REVIEW COMMENTS

APPROVED

SEPT. 10, 1987
 DATE
David R. Kelley
 CHIEF ENGINEER
Arthur J. Jones
 DIRECTOR OF PLANNING
 AND PRE-CONSTRUCTION
Gordon B. MacArthur
 TRAFFIC AND SAFETY ENGINEER

**DELINEATION, BARRICADES AND
 DETOURS FOR CONSTRUCTION
 AREAS**



**STANDARD
 E-107**