

DIMENSIONS (INCHES)											
SIGN	A	B	C	D	E	F	G	H	J	K	L
STD.	30	1/2	3/4	5/8	3	3/4	5-3/16	5-5/8	13-11/16	13-1/16	1-7/8
FWY.	48	3/4	1-1/4	5/8	1-1/4	8-1/4	9	21-7/8	20-7/8	3	

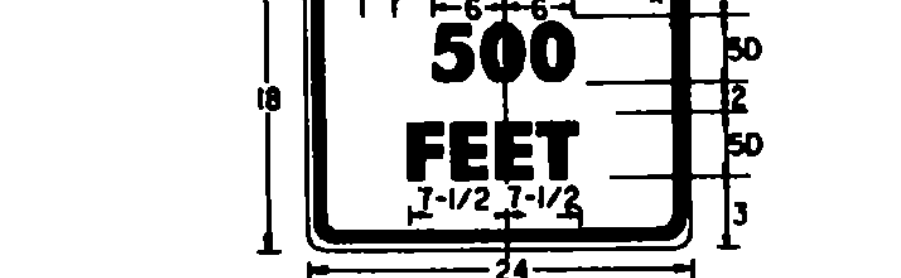

DIMENSIONS (INCHES)						
SIGN	A	B	C	D	E	F
STD.	36	3/4	1	2-3/4	13-1/2	14-5/8
FWY.	48	3/4	1-1/4	3-3/4	18	19-1/2

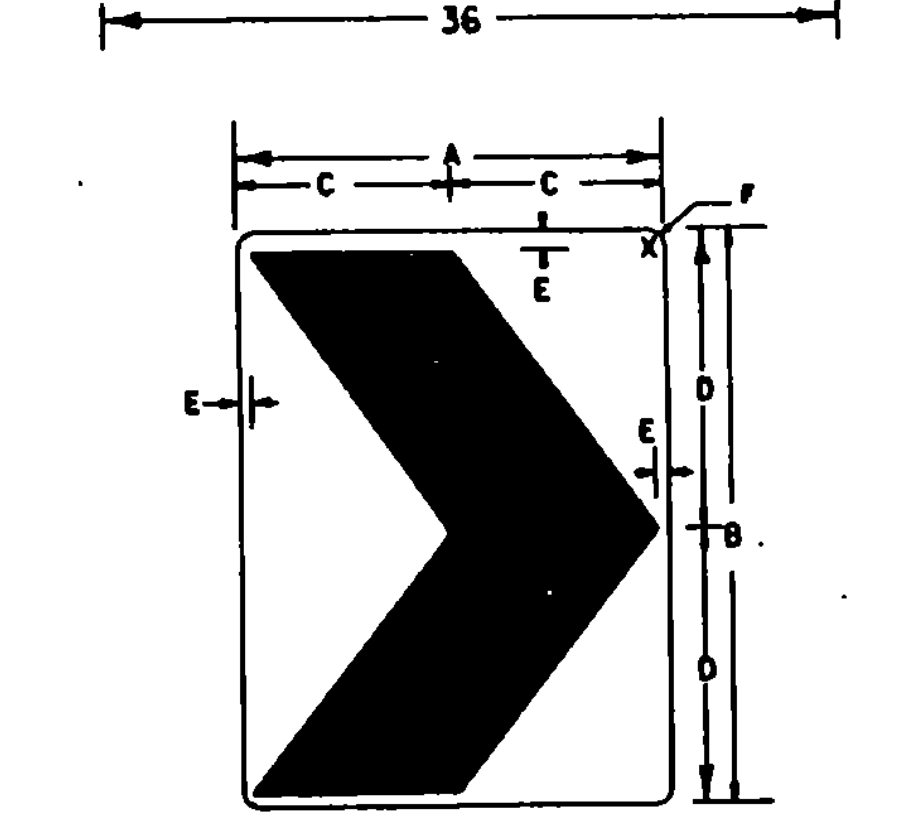
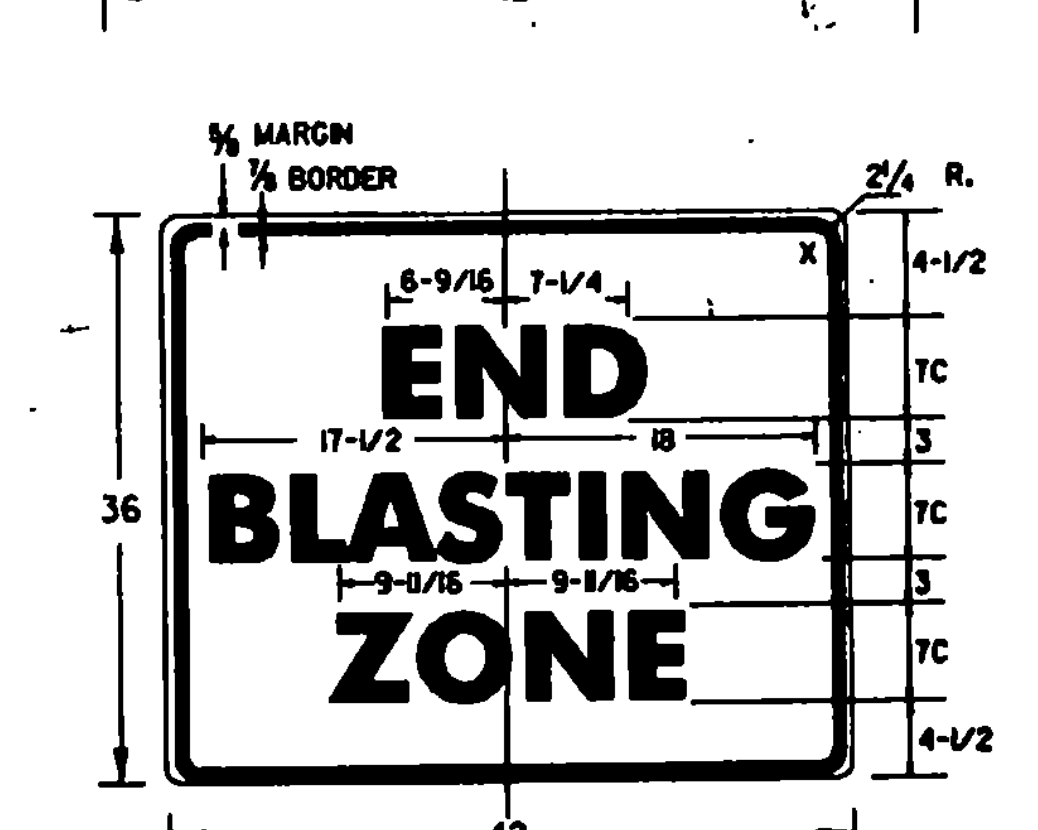
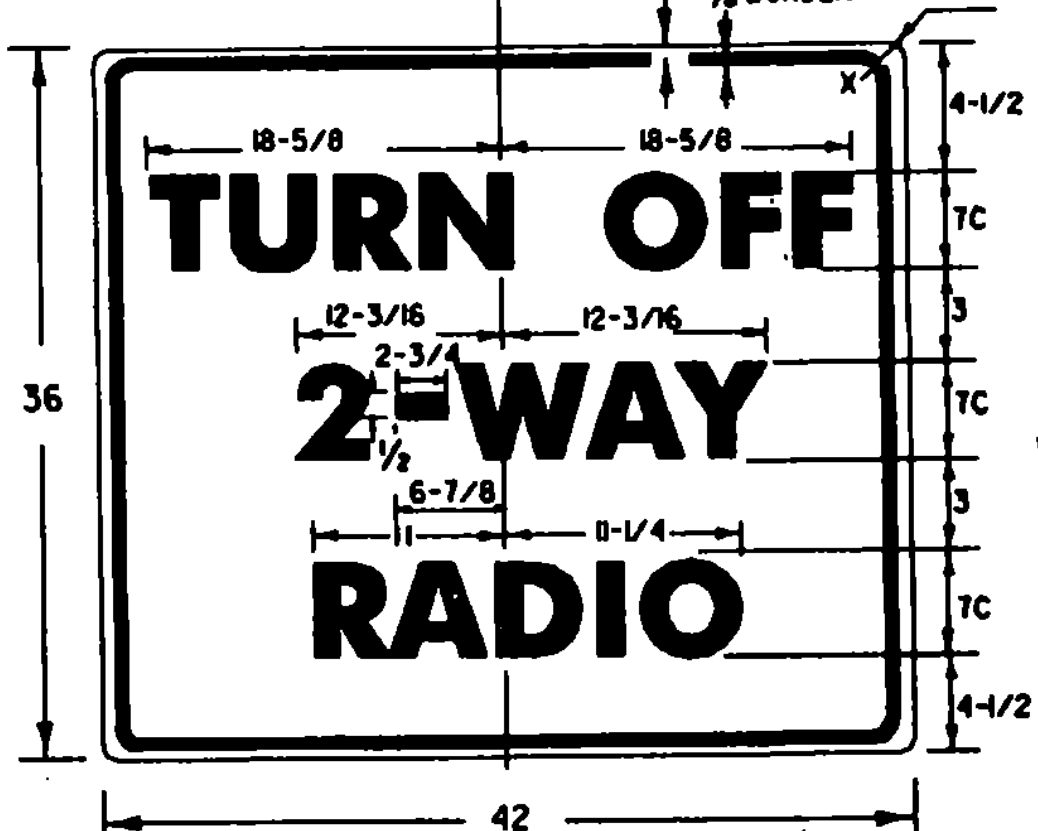
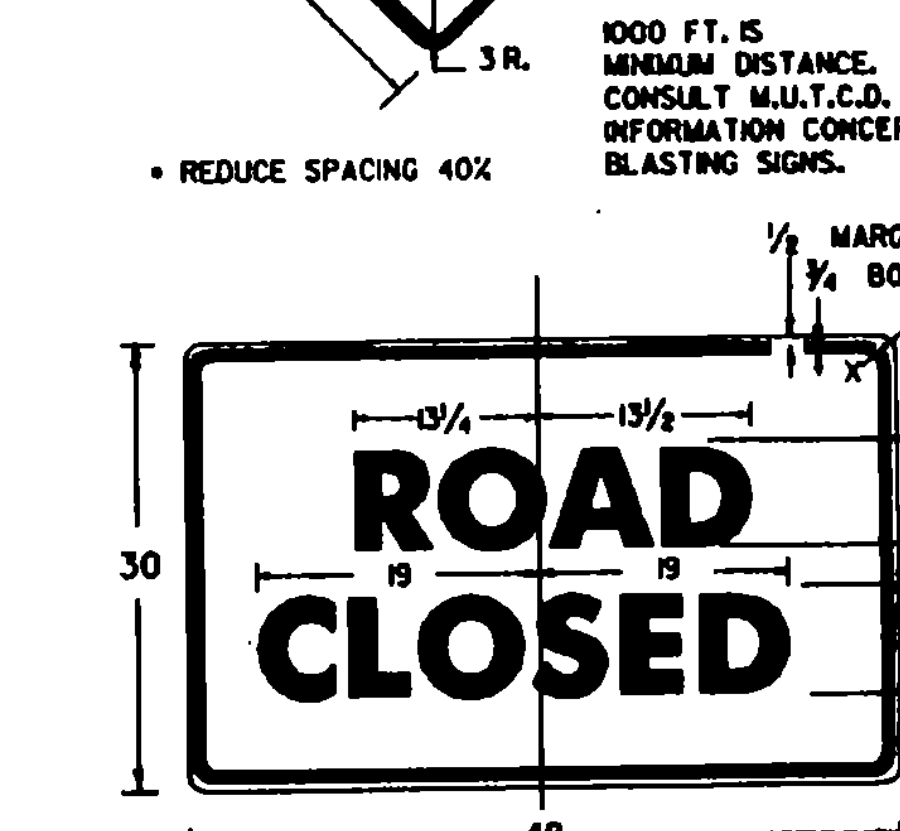
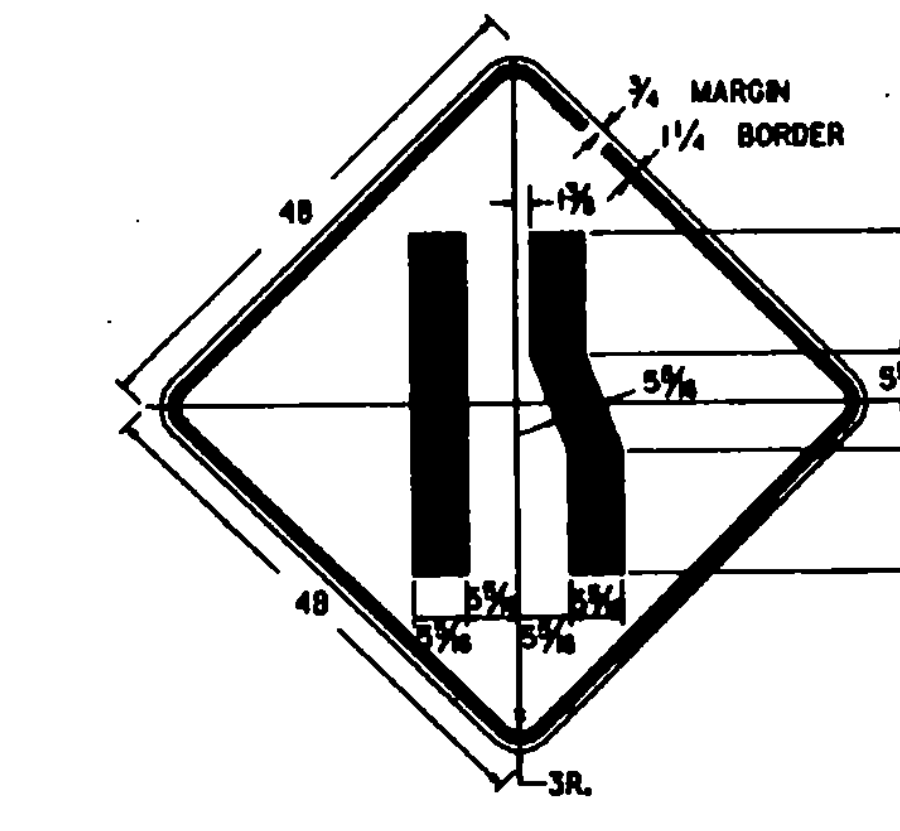
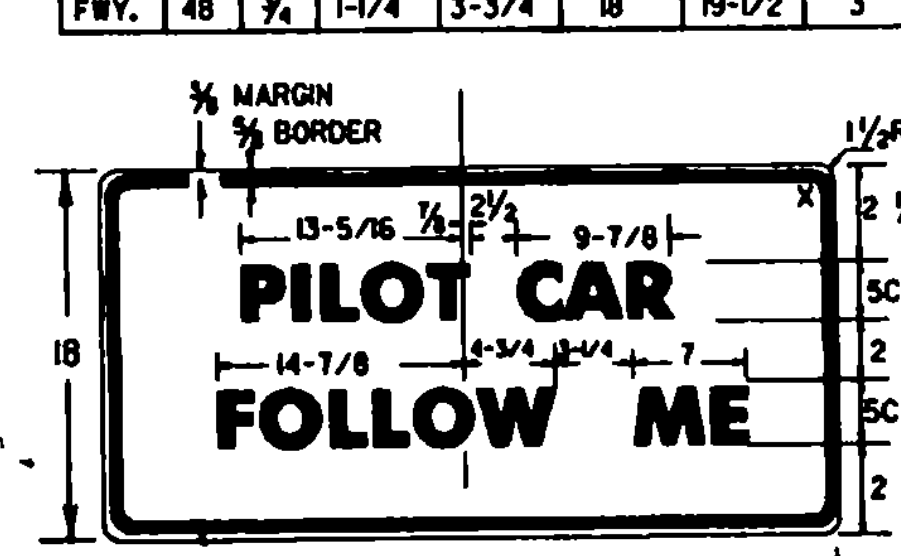
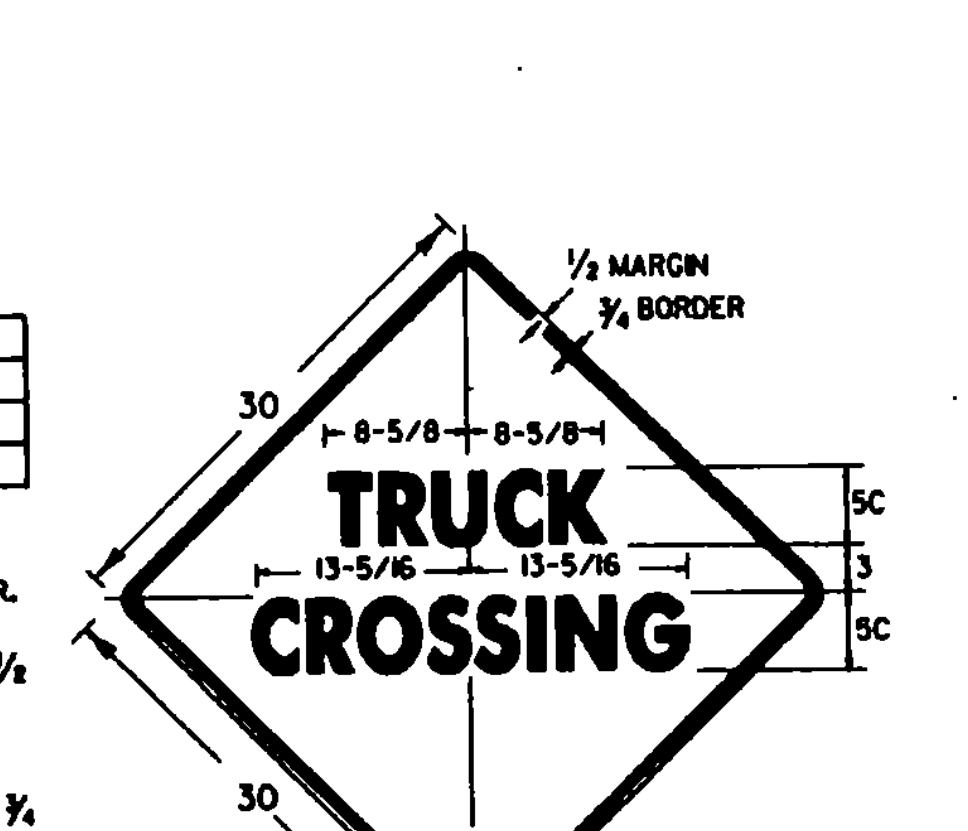

DIMENSIONS (INCHES)					
SIGN	A	B	C	D	F
STD.	18	24	9	12	3/4
SPECIAL	24	30	12	15	1-1/2
EXPWY.	30	36	15	18	1-7/8
FRWY.	36	48	18	24	2-1/4

COLORS
CHEVRON - BLACK
BACKGROUND - YELLOW (REFL.)

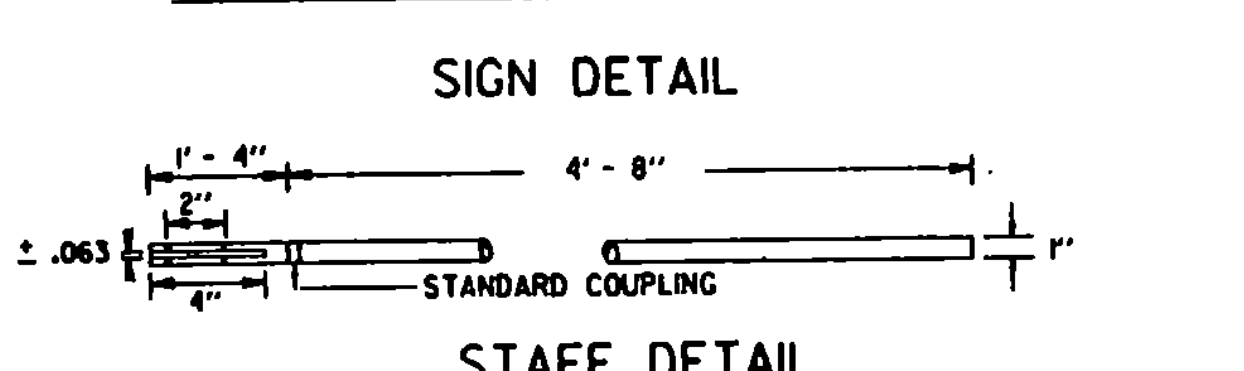
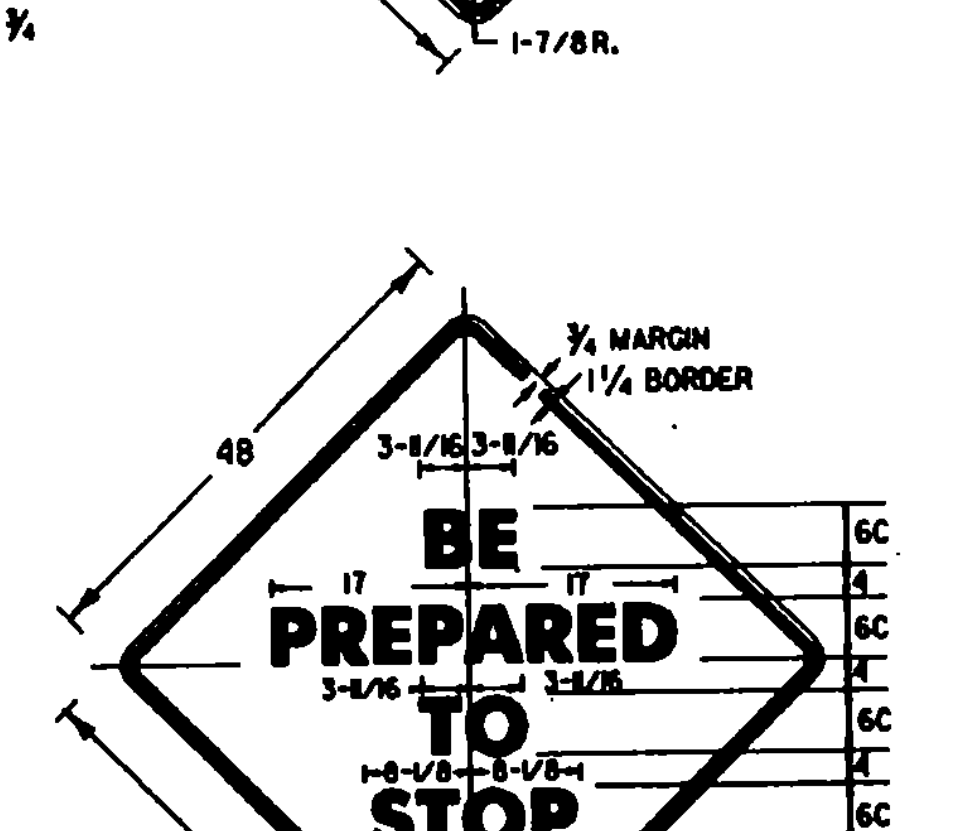

MATERIALS
THE SIGN MATERIALS SHALL BE 0.063" ALUMINUM WITH COLORS AS INDICATED ON DETAILS.
THE STAFF SHALL BE RIGID ALUMINUM CONDUIT OR TUBING WITH A WALL THICKNESS OF 0.025".

MOUNTING
THE STAFF SHALL BE MOUNTED WITH EITHER TWO 1/4" DIAMETER ALUMINUM BOLTS OR TWO 1/4" DIAMETER ALUMINUM RIVETS.

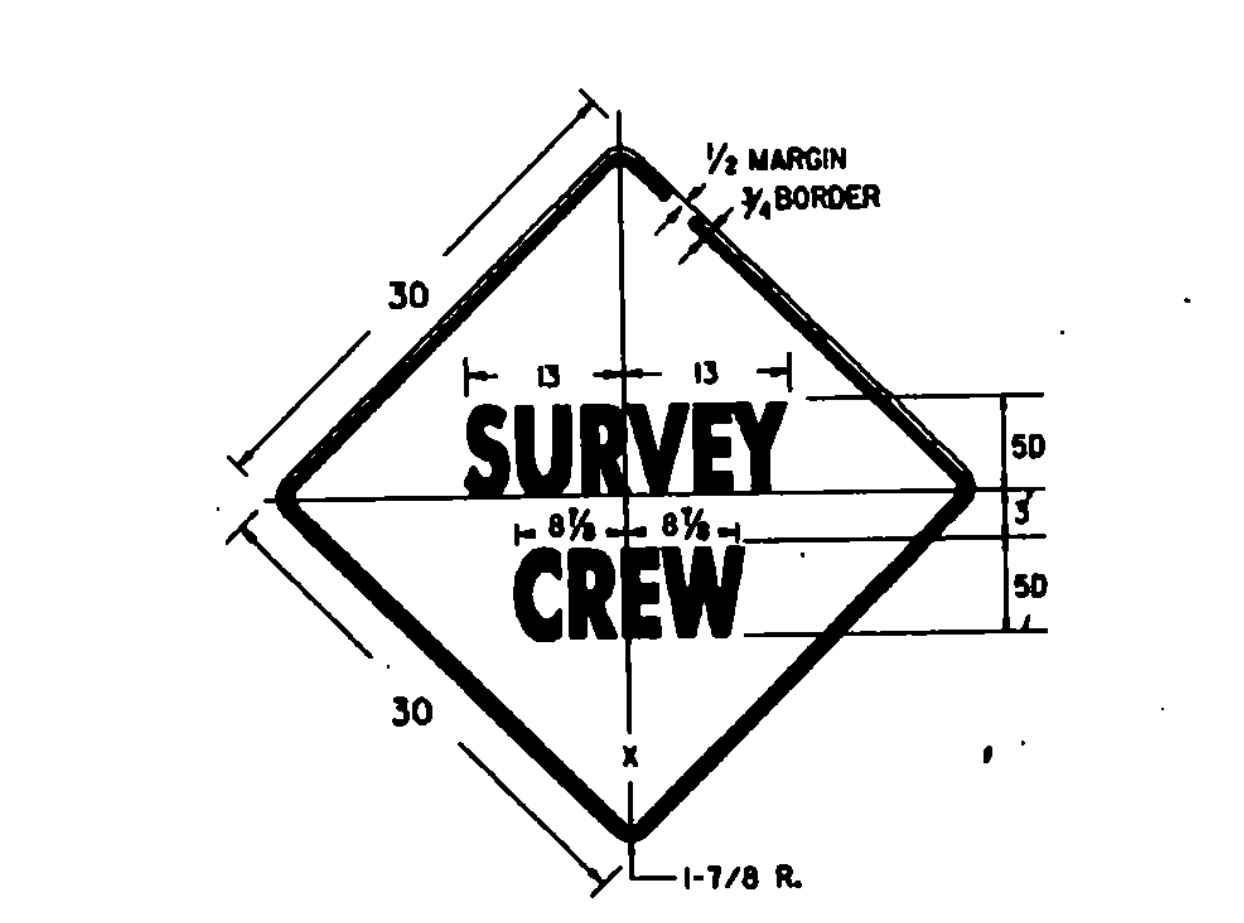

NOTES
SEE STANDARD SHEET E-100 FOR NOTES AND TEXT DETAILS
COLORS FOR SIGNS SHOWN ON THIS SHEET SHALL BE BLACK TEXT, BORDER AND SYMBOLS ON A REFLECTORIZED (ENCAPSULATED LENS) ORANGE BACKGROUND, UNLESS OTHERWISE NOTED. THE EXCEPTIONS ARE THE CHEVRON, ROAD CLOSED, AND PADDLE SIGNS. SIGN DETAILS INDICATE THE APPROPRIATE COLOR.
EXISTING "BRIDGE" SIGNS MAY BE USED UNTIL THE SIGN NEEDS REPLACEMENT. NEW SIGNS SHALL SHOW REFERENCE TO "ROAD" CONSTRUCTION, HOWEVER, SIGN TEXT SHALL BE CONSISTENT THROUGHOUT THE PROJECT.
SIGNS USED ONLY FOR DAYTIME MAINTENANCE OPERATIONS DO NOT NEED TO BE REFLECTORIZED, HOWEVER, THESE SIGNS SHALL BE LABELED "DAYTIME USE ONLY" ON THE BACK OF THE SIGN PANEL WITH 3" SERIES C LETTERS.

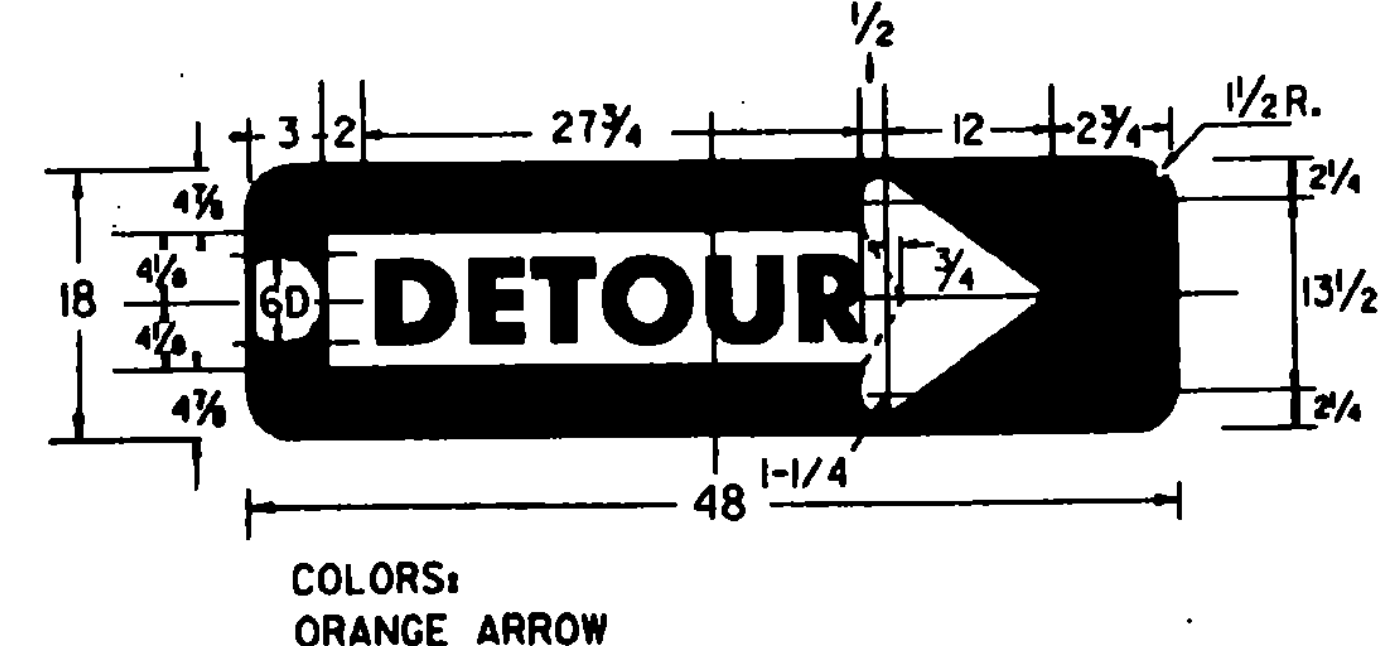

REVISIONS AND CORRECTIONS

APPROVED

OCT. 30, 1987
DATE

David S. Kelley
CHIEF ENGINEER

Arthur J. Goss
DIRECTOR OF PLANNING
AND PRE-CONSTRUCTION

Stephen B. MacArthur
TRAFFIC AND SAFETY ENGINEER

CONSTRUCTION SIGN DETAILS

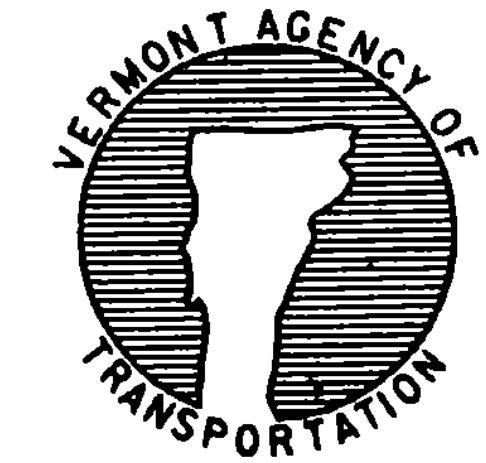

STANDARD E-101