

MILLED RUMBLE STRIPS (CENTERLINE)  
STA. E 124+00 TO E 129+00, CL

DURABLE 4 INCH WHITE LINE, (OPTION CC BID ITEMS)  
TEMPORARY 4 INCH WHITE LINE, PAINT  
(ALL LINES WILL INCLUDE EDGE LINE BREAKS  
AND RADII FOR SIDE ROADS)  
STA. E 124+00 TO E 129+00, SOLID LT & RT

DURABLE 4 INCH YELLOW LINE, (OPTION DD BID ITEMS)  
TEMPORARY 4 INCH YELLOW LINE, PAINT  
(ALL LINES WILL INCLUDE  $\phi$  BREAKS FOR SIDE ROADS)  
STA. E 124+00 TO E 129+00, SOLID LT & RT

REMOVING SIGNS  
AS SHOWN - 1

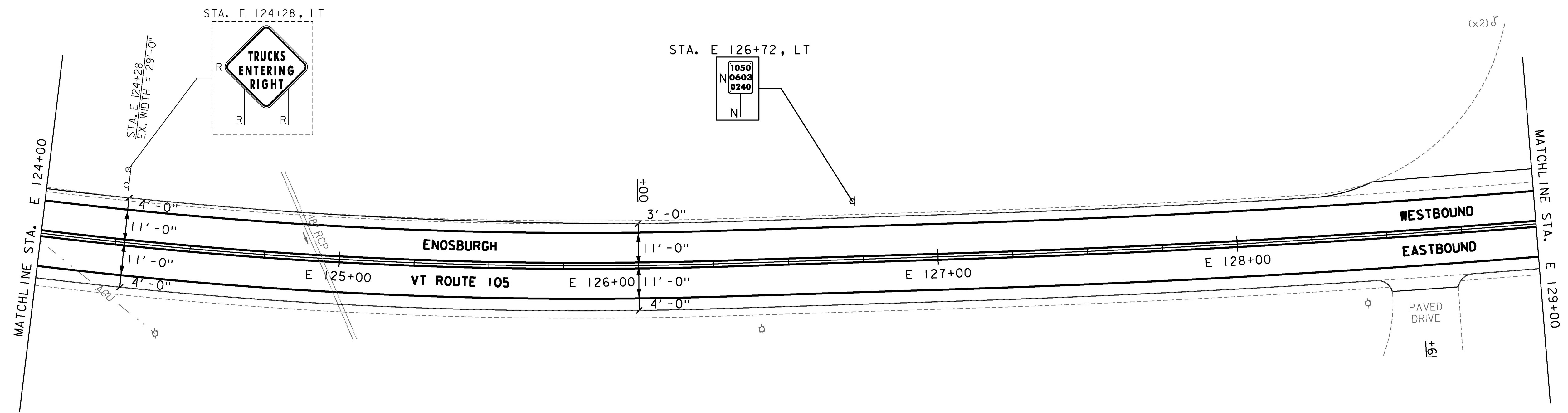
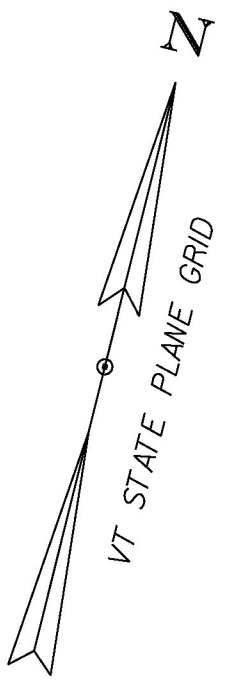

**NOTES:**

1. FOR LEGENDS, SEE SHEETS 3 & 3I.
2. ALL EXISTING SIGNS NOT SHOWN ON THE PLANS SHALL BE RETAINED.
3. ALL UTILITY LOCATIONS SHOWN ARE APPROXIMATE AND SHOULD BE VERIFIED PRIOR TO ANY WORK COMMENCING.

PROJECT NAME:	ENOSBURGH-RICHFORD
PROJECT NUMBER:	STP 2969(I)
FILE NAME:	z16vi04bdr.dgn
PROJECT LEADER:	G. EDWARDS
DESIGNED BY:	G. BURGMEIER
PLAN SHEET 10	
PLOT DATE:	4/2/2018
DRAWN BY:	G. BURGMEIER
CHECKED BY:	J. LITTLE
SHEET	40 OF 222

