

TEMPORARY 4 INCH WHITE LINE, PAINT
 4 INCH WHITE LINE, WATERBORNE PAINT
 (ALL LINES WILL INCLUDE EDGE LINE
 BREAKS AND RADII FOR SIDE ROADS)
 328+00 TO 356+00 LT & RT (SOLID)

TEMPORARY 4 INCH YELLOW LINE, PAINT
 4 INCH YELLOW LINE, WATERBORNE PAINT
 (ALL LINES WILL INCLUDE ϕ
 BREAKS FOR SIDE ROADS)
 328+00 TO 356+00 LT & RT (SOLID)

STEEL BEAM GUARDRAIL, GALVANIZED
 332+16.5 TO 332+54 LT
 333+58 TO 333+95.5 LT
 337+75.5 TO 338+13 LT

REMOVAL AND DISPOSAL OF GUARDRAIL
 332+16.5 TO 332+54 LT
 333+58 TO 333+95.5 LT
 337+75.5 TO 338+13 LT

ANCHOR FOR STEEL BEAM RAIL
 3 (SEE STANDARD G-1d)

DELINEATOR WITH STEEL POST
 332+54 LT
 333+58 LT
 338+13 LT

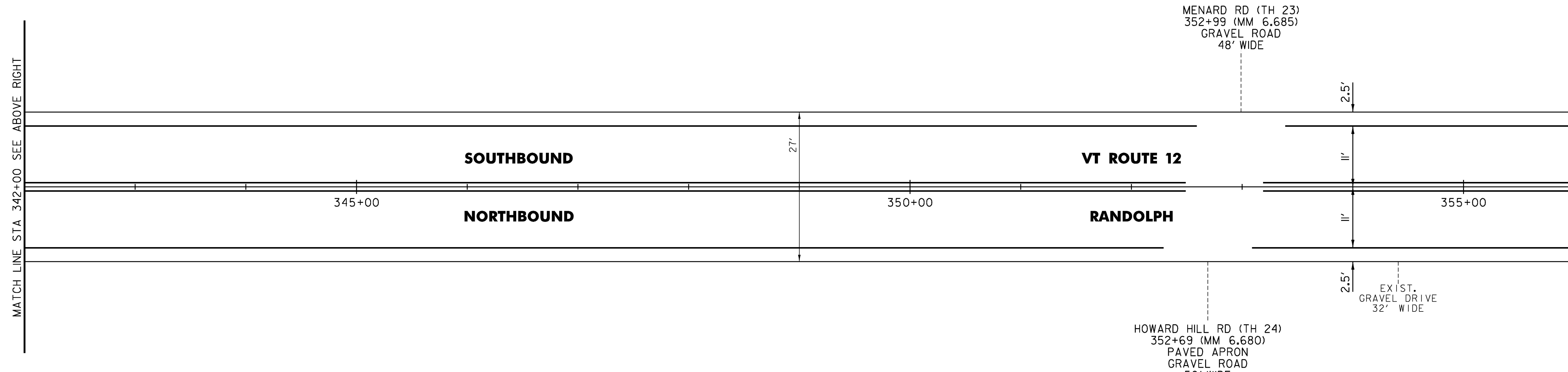
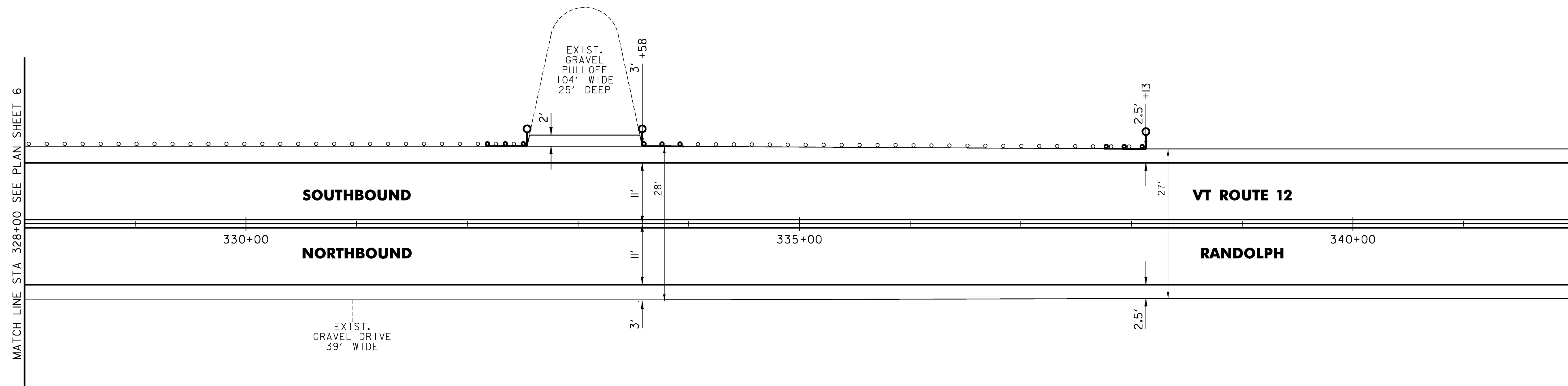

NOT TO SCALE

PROJECT NAME:	RANDOLPH-BRAINTREE
PROJECT NUMBER:	STP FPAV(7)
FILE NAME:	z16v028bdr.dgn
PROJECT LEADER:	P. SHEDD
DESIGNED BY:	N. LEMAY
PLAN SHEET	7
PLOT DATE:	2/8/2017
DRAWN BY:	S. GOODWIN
CHECKED BY:	P. SHEDD
SHEET	20 OF 24