

TEMPORARY 4 INCH WHITE LINE, PAINT  
 4 INCH WHITE LINE, WATERBORNE PAINT  
 (ALL LINES WILL INCLUDE EDGE LINE  
 BREAKS AND RADII FOR SIDE ROADS)  
 N 25+00 TO N 53+00 LT & RT (SOLID)

TEMPORARY 4 INCH YELLOW LINE, PAINT  
 4 INCH YELLOW LINE, WATERBORNE PAINT  
 (ALL LINES WILL INCLUDE  $\frac{1}{4}$   
 BREAKS FOR SIDE ROADS)  
 N 25+00 TO N 53+00 LT & RT (SOLID)

STEEL BEAM GUARDRAIL, GALVANIZED  
 N 27+00 TO N 27+50 LT  
 N 34+64.5 TO N 35+02 LT  
 N 36+99 TO N 37+49 LT  
 N 37+18 TO N 37+55.5 RT  
 N 38+46.5 TO N 38+84 LT  
 N 47+71.5 TO N 47+96.5 RT

ANCHOR FOR STEEL BEAM RAIL  
 5 (SEE STANDARD G-1d)

REMOVE AND RESET GUARDRAIL  
 N 27+50 TO N 28+00 LT  
 N 34+39.5 TO N 34+64.5 LT  
 N 38+21.5 TO N 38+46.5 LT  
 N 44+94.5 TO N 45+07 RT  
 N 45+34 TO N 47+21.5 RT

REMOVAL AND DISPOSAL OF GUARDRAIL  
 N 27+00 TO N 27+50 LT  
 N 34+64.5 TO N 35+02 LT  
 N 36+99 TO N 37+49 LT  
 N 38+46.5 TO N 38+84 LT  
 N 37+18 TO N 37+55.5 RT  
 N 47+71.5 TO N 47+96.5 RT

DELINEATOR WITH STEEL POST  
 N 27+00 LT  
 N 35+02 LT  
 N 36+99 LT  
 N 37+18 RT  
 N 38+84 LT  
 N 45+07 RT  
 N 45+34 RT

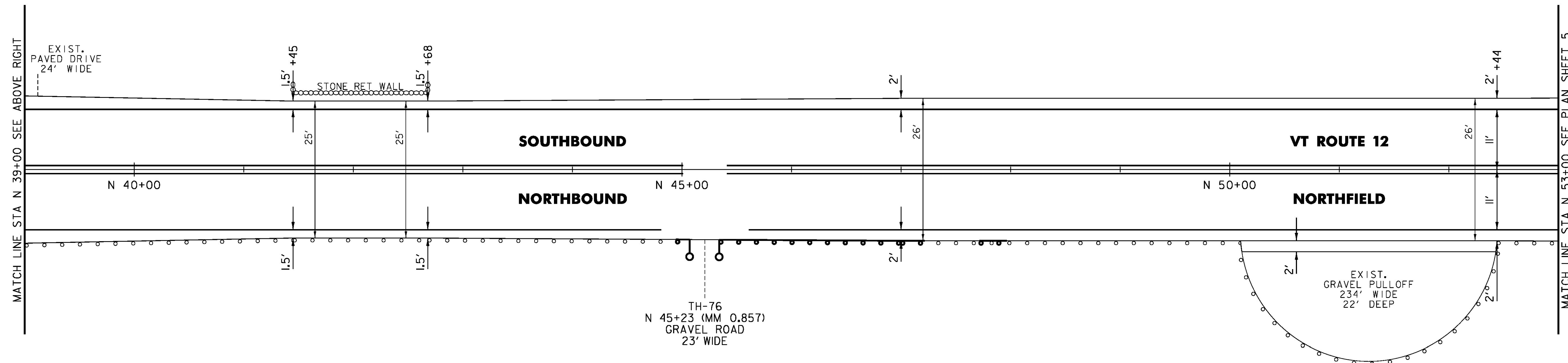
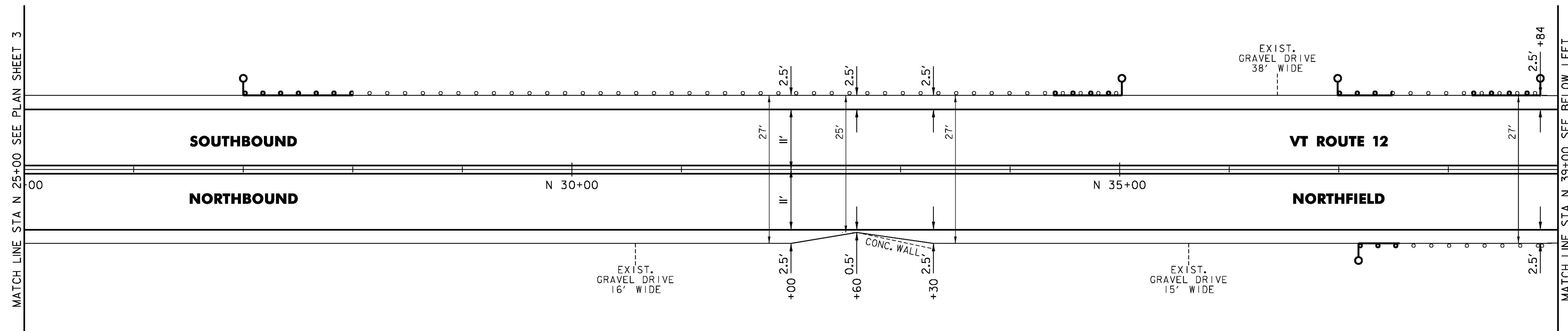

NOT TO SCALE

PROJECT NAME:	ROXBURY-NORTHFIELD
PROJECT NUMBER:	STP FPAV(6)
FILE NAME:	z16v027bdr.dgn
PROJECT LEADER:	P. SHEDD
DESIGNED BY:	N. LEMAY
PLAN SHEET 4	
PLOT DATE:	2/8/2017
DRAWN BY:	S. GOODWIN
CHECKED BY:	P. SHEDD
SHEET 17	OF 21