

TEMPORARY 4 INCH WHITE LINE, PAINT
 4 INCH WHITE LINE, WATERBORNE PAINT
 (ALL LINES WILL INCLUDE EDGE LINE
 BREAKS AND RADII FOR SIDE ROADS)
 63+00 TO 91+00 LT & RT (SOLID)

TEMPORARY 4 INCH YELLOW LINE, PAINT
 4 INCH YELLOW LINE, WATERBORNE PAINT
 (ALL LINES WILL INCLUDE ϕ
 BREAKS FOR SIDE ROADS)
 63+00 TO 66+53 LT & RT (SOLID)
 66+53 TO 72+86 LT (SOLID), RT (DASHED)
 72+86 TO 78+94 LT (DASHED), RT (SOLID)
 78+94 TO 86+06 LT & RT (SOLID)
 86+06 TO 91+00 LT (DASHED), RT (SOLID)

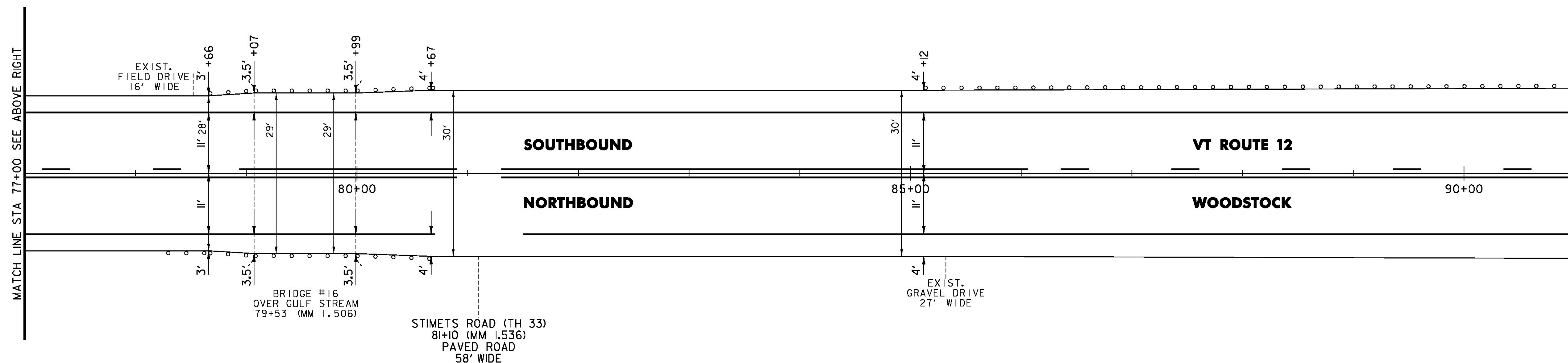
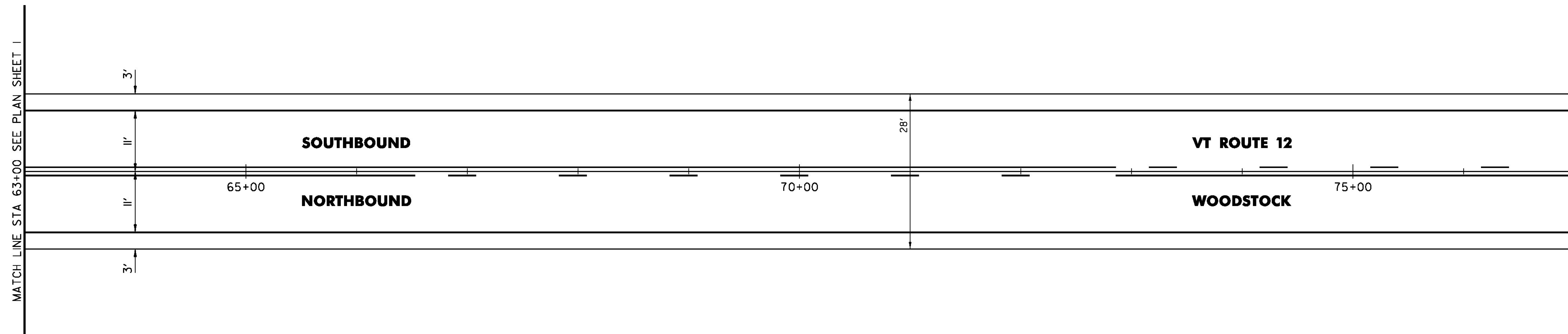

NOT TO SCALE

PROJECT NAME:	WOODSTOCK-BARNARD
PROJECT NUMBER:	STP FPAV(3)
FILE NAME:	z16v024bdr.dgn
PROJECT LEADER:	P. SHEDD
DESIGNED BY:	N. LEMAY
PLAN SHEET 2	
PLOT DATE:	6/2/2016
DRAWN BY:	S. GOODWIN
CHECKED BY:	P. SHEDD
SHEET	12 OF 26