

ELEVATION

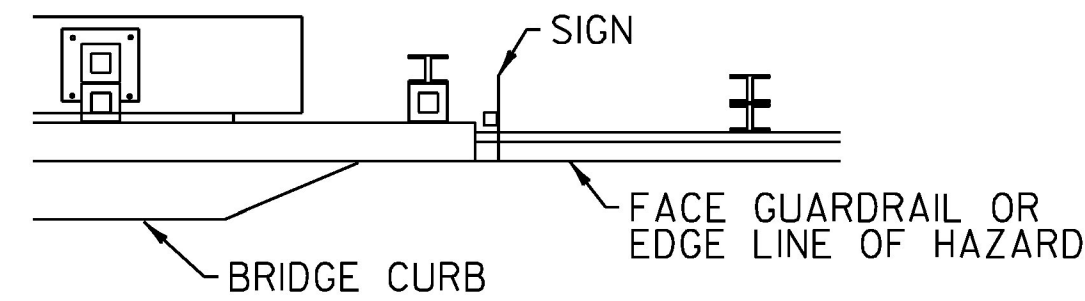

PLAN VIEW

NOTES:

1. OBJECT MARKER SHOULD BE INSTALLED SO THAT THE INSIDE EDGE OF THE SIGN IS AS CLOSE AS POSSIBLE TO THE FACE OF GUARDRAIL OR INSIDE EDGE OF THE HAZARD.
2. THE SIGN SHALL BE MOUNTED SO THE DIAGONAL STRIPES SLOPE DOWNWARDS TOWARD THE ROAD CENTERLINE.
3. ASSEMBLY HARDWARE SHALL CONFORM TO SUBSECTION 750.12 (a). RIVETS SHALL NOT BE USED.
4. SIGN BASE MATERIAL SHALL BE 0.100" FLAT SHEET ALUMINUM.
5. MOUNTING HARDWARE FOR SIGNS ATTACHED TO ABUTMENTS OR HAZARDS SHALL BE APPROVED BY THE ENGINEER.

OBJECT MARKER (OM3-L OR OM3-R) INSTALLATION

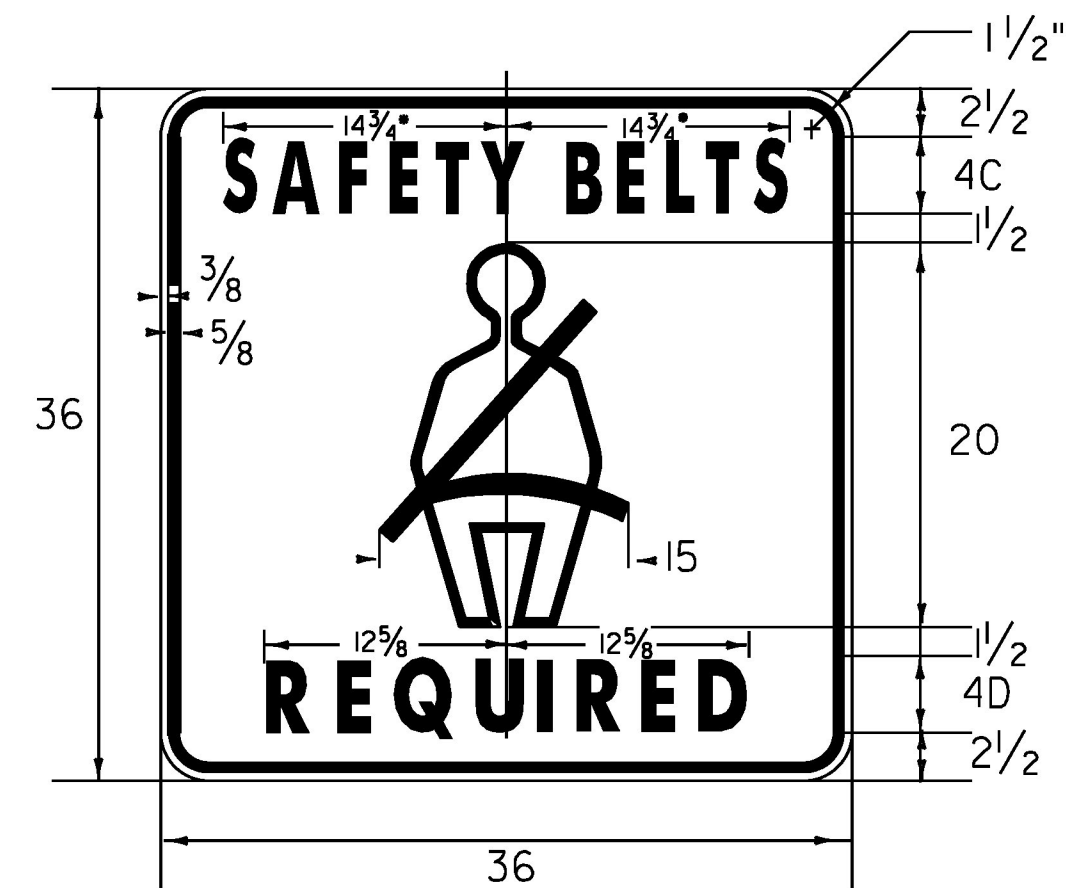

VR-601

BLACK ON WHITE

•REDUCE SPACING 50%

FOR SEAT BELT SYMBOL LAYOUT SEE THE 2004 STANDARD HIGHWAY SIGNS BOOK PAGE 6-21.



VD-421

NOTE:

FOR THE WORDS "WELCOME TO" USE GERBER FONT MURRAY HILL BOLD OR EQUIVALENT. TEXT COLOR IS GREEN. ALL OTHER TEXT USE GERBER FONT SOUVENIR DEMIBOLD OR EQUIVALENT. TEXT COLOR IS WHITE. REFER TO VAOT STD. T-2 FOR COLORS.

MATERIALS:

SEE VAOT STD. T-2 FOR MATERIALS

REMOVAL OF EXISTING DELINEATOR LOCATIONS:

TOWN:	DIRECTION & ROUTE:	MILE POINT:	NO. OF REMOVALS
CLARENDON	7B SB	0.481	1
LUDLOW	103 SB	3.654	1
MOUNT HOLLY	103 NB	4.034	1
WALL ING FORD	103 NB	0.320	1
VERNON	142 NB	1.645-1.680	3
VERNON	142 NB	4.260-4.273	4
VERNON	142 NB	4.289-4.313	3
VERNON	142 NB	5.354-5.361	13
BRATTLEBORO	142 SB	1.205	1
BRATTLEBORO	142 SB	1.235	2
BRATTLEBORO	142 SB	1.255	2

PROPOSED DELINEATOR LOCATIONS:

TOWN:	DIRECTION & ROUTE:	MILE POINT:	NO. OF NEW TYPE I (POSTS):	POST SPACING:
VERNON	142 NB	1.645-1.680	6 (3)	N/A
VERNON	142 NB	3.940-4.129	22 (11)	100'
VERNON	142 NB	4.260-4.273	8 (4)	N/A
VERNON	142 NB	4.289-4.313	6 (3)	N/A
VERNON	142 NB	5.354-5.361	12 (6)	7'
WALL ING FORD	140 WB	1.480-1.457	8 (4)	40'

NOTES:

1. DELINEATORS SHALL BE INSTALLED AT THE LOCATIONS PROVIDED IN THE CHART ABOVE OR AS DIRECTED BY THE ENGINEER.
2. ALL WORK ASSOCIATED WITH INSTALLING NEW DELINEATORS WILL BE PAID FOR UNDER CONTRACT ITEM 676.10 DELINEATOR WITH STEEL POST. EACH DELINEATOR INSTALLATION SHALL CONSIST OF TWO TYPE II (6"x8") DELINEATOR PLAQUES MOUNTED BACK-TO-BACK ON A 1.75" SQUARE STEEL POST INSTALLED IN AN ANCHOR.
3. REFER TO STANDARD SHEET T-40.

DELINEATORS WITH RETROREFLECTIVE SHEETING

ALL DIMENSIONS SHOWN IN INCHES, UNLESS OTHERWISE NOTED.

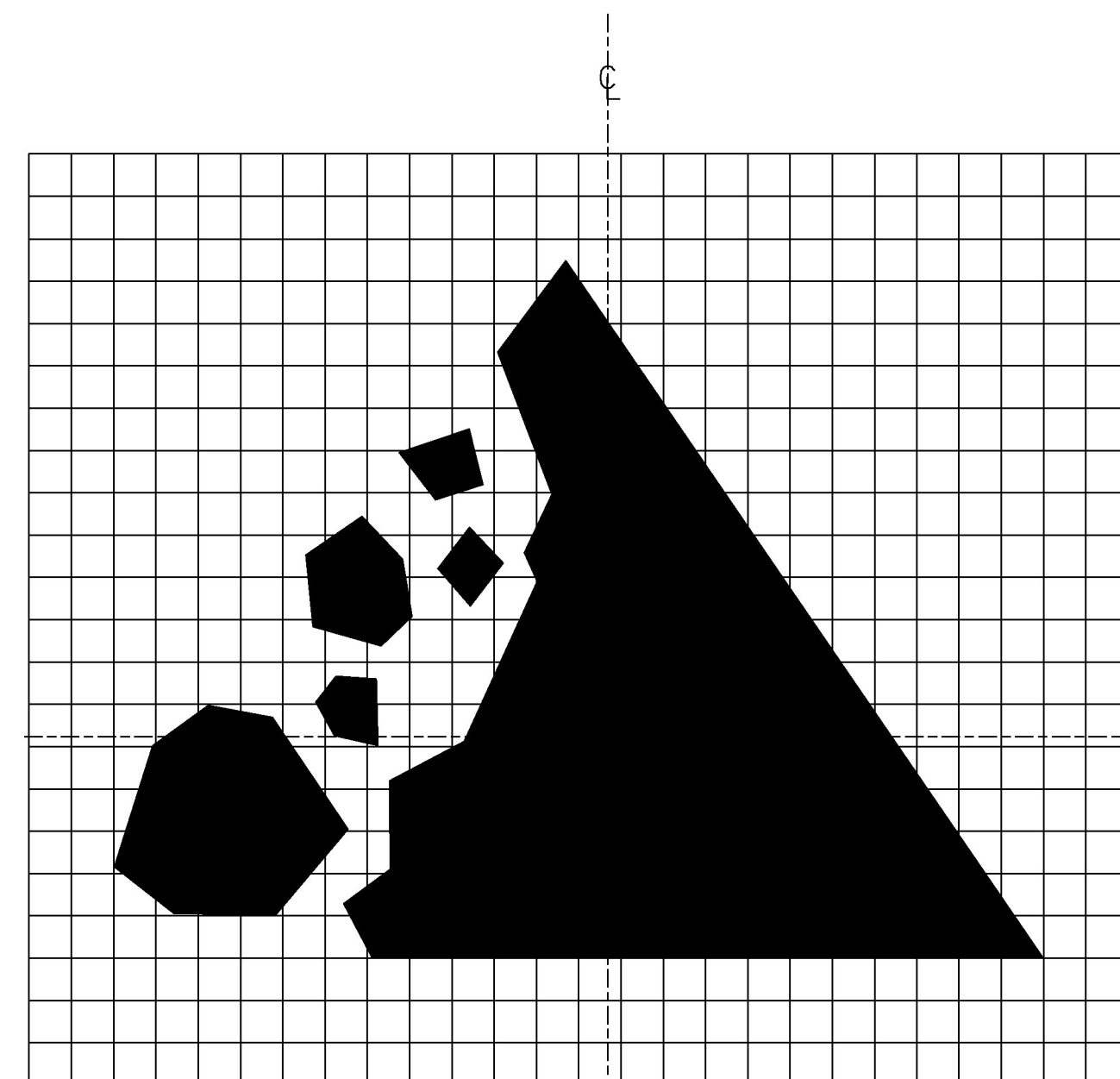

1 SQUARE = 1"

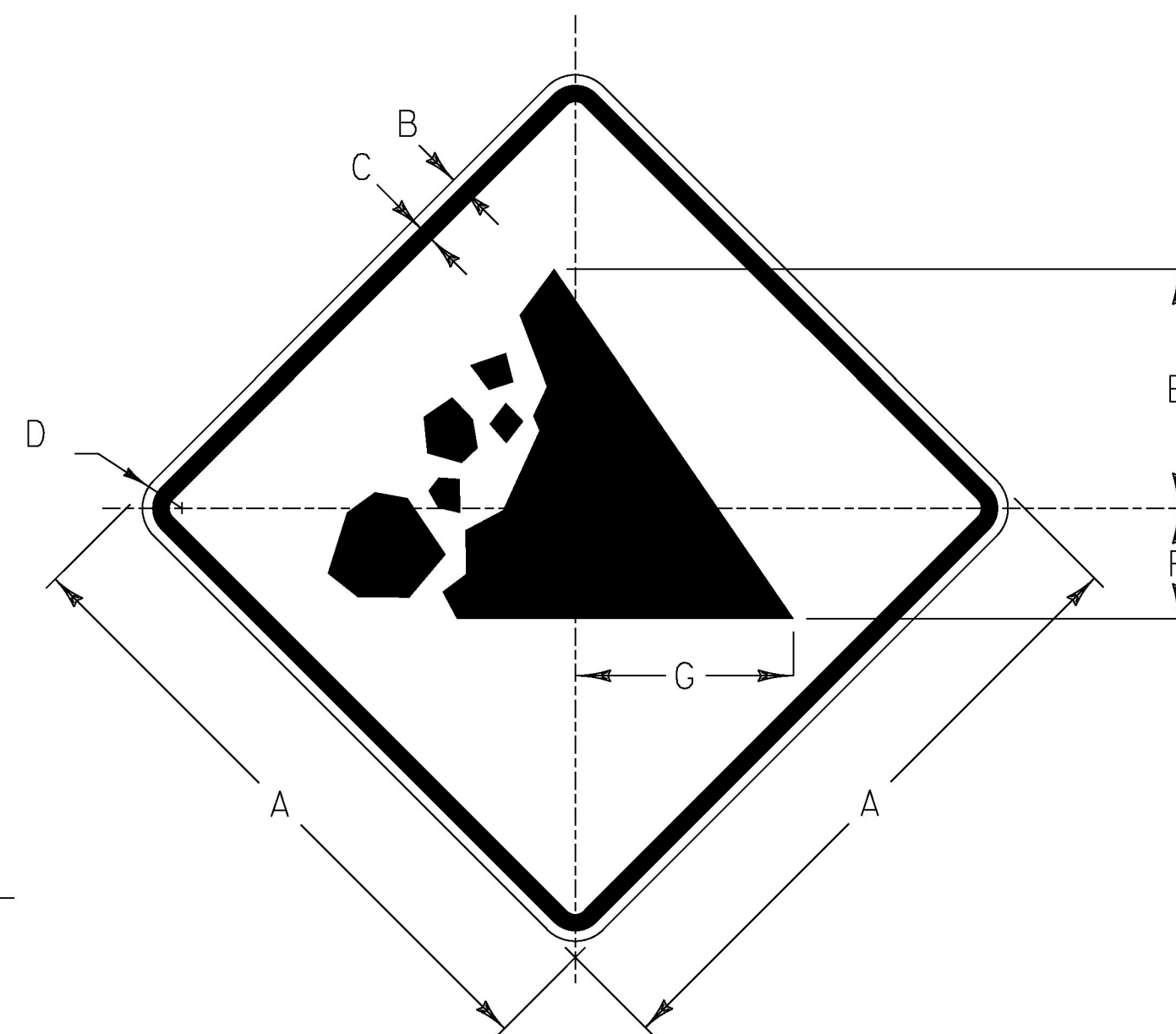

VW-285

COLORS
TEXT AND BORDER - BLACK (NON-REFL.)
BACKGROUND - YELLOW (REFL.)

SIGN	DIMENSIONS (INCHES)						
	A	B	C	D	E	F	G
STD.	30	1/2	3/4	1 1/2	1 1/4	5/4	10 5/16
SPECIAL	48	3/4	1 1/4	3	18	8 3/8	16 1/2

NOT TO SCALE

PROJECT NAME: STATEWIDE-SOUTH REGION
PROJECT NUMBER: STPG SIGN(57)

FILE NAME: z16+041frm.dgn PLOT DATE: 2/27/2017
PROJECT LEADER: D. MUNRO DRAWN BY: P. MCKECHNIE
DESIGNED BY: S. GOODWIN CHECKED BY: J. BRZEZOWSKI
SIGN DETAILS SHEET 1 SHEET 6 OF 264