

EAST COAST SIGNALS APPROVED FOR SUBMITTAL 11-4-16

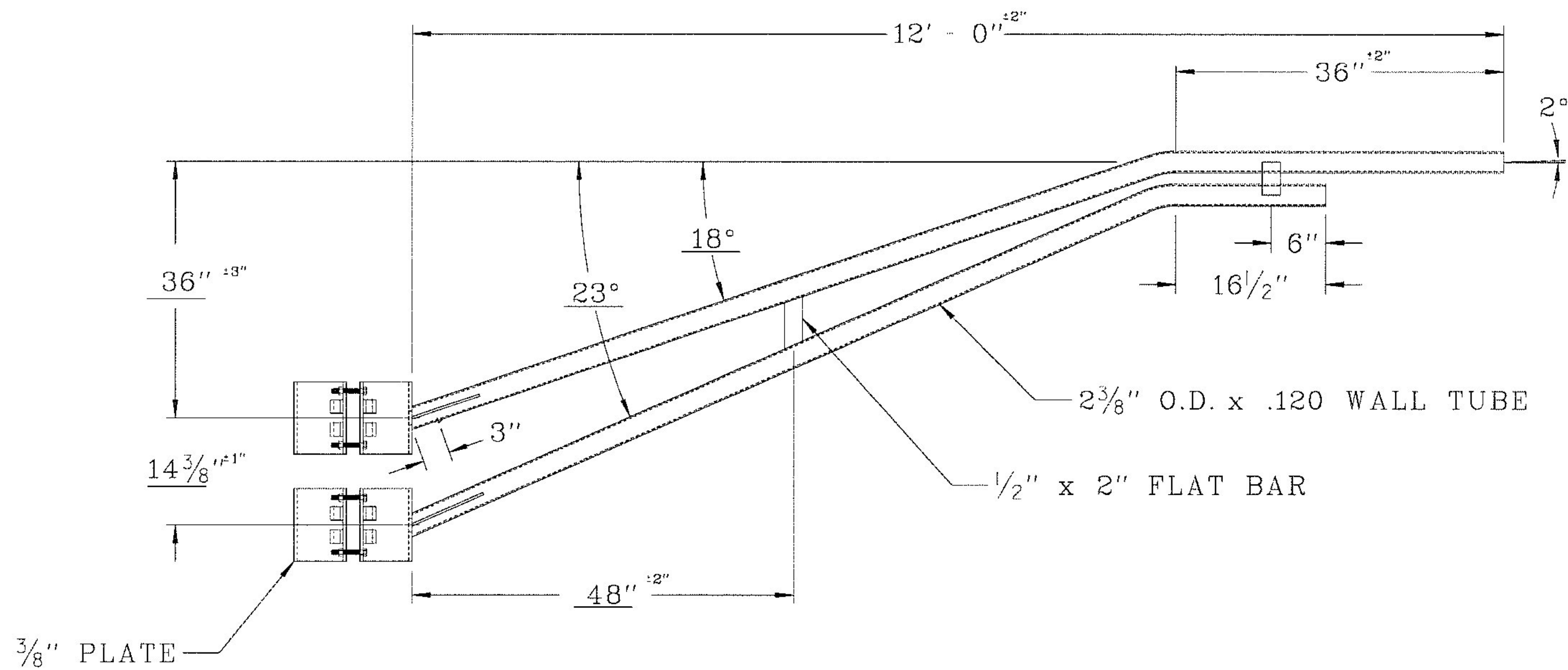
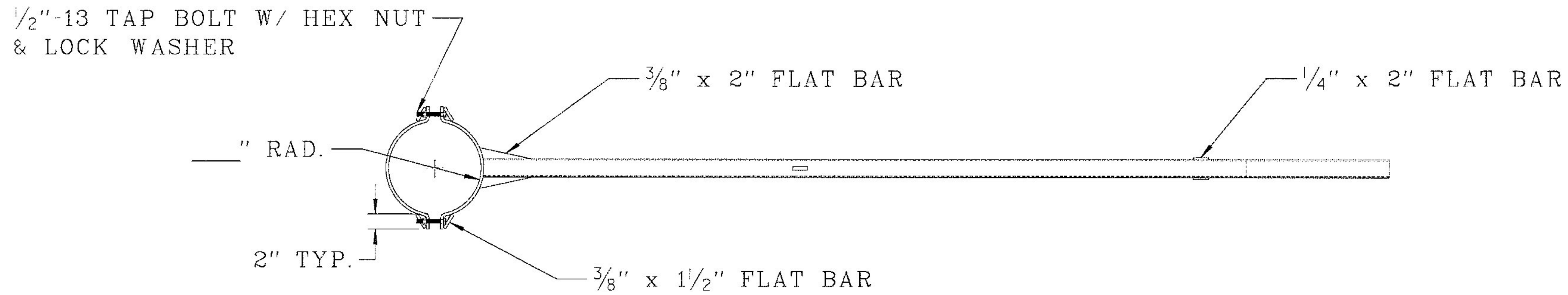

SHT. 2 OF 2

FOR SHOP DWG. SEE SHT. 1 OF 2

REV.	DATE	DESCRIPTION	BY	TOLERANCES: UNLESS OTHERWISE SPECIFIED	THIS DRAWING AND ANY ACCOMPANYING DATA PERTAINING THERETO IS THE PROPERTY OF FABRICATED METALS CORPORATION IT CONTAINS CONFIDENTIAL INFORMATION AND IS REGARDED AS UNPUBLISHED MANUSCRIPT. THIS MATERIAL SHALL BE USED BY THE RECIPIENT ONLY FOR THE PURPOSE INTENDED AS INDICATED BY STAMPING OR ACCOMPANYING DOCUMENT OR TRANSMITTAL. IT SHALL NOT BE DUPLICATED, REVEALED, SOLD OR SHARED WITH OTHERS WITHOUT PRIOR WRITTEN PERMISSION OF FABRICATED METALS CORPORATION.	UTILITY METALS (A DIV. OF FABRICATED METALS CORP.) P.O. BOX 9054 LOUISVILLE KY. 40209-9054 PHONE (502) 363-6681 TOLL FREE (800) 627-8276 FAX (502) 368-2656	JOB: C200S120RN 12' TRUSS FOR _____" DIA.	
03	3-8-07	CHGD GUSSETS ECR ~ 068	K.M.B.	FRACTIONS: ± 1/4"			APPROVED:	REV. 03
02	11-16-99	ADDED SALES DWG	J.F.K.	DECIMALS: 2 PLACE ± .030, 3 PLACE ± .030			DWN: J. F. K.	DATE: 2-6-98
01	9-23-99	ON ITEM #8 2" WAS 1 1/2"	J.F.K.	ANGLES: ± 1 DEG.			SCALE: 1/16" = 1"	DWG: G-4664-03