



ENGINEERING COMPANY, INC

Route 145, Winthrop Road
Chester, Ct 06412-0684
TELEPHONE: (860) 526-9504
TOLL FREE: 1-800-637-4736
FACSIMILE: (860) 526-4784

Approved	
BY:	M. Lacroix
DATE:	02/17/2017
RESUBMIT:	No
RECEIVED:	July 31, 2017
CRD BY:	K. Record
STATE OF VERMONT AGENCY OF TRANSPORTATION	

Doc No. 04-0113059-01

IS3 SERIES

STROBE LIGHT BEACONS

IS3006, 10-40 VDC, 12-28 VAC, SINGLE FLASH

IS3010, 12/24 VOLTS DC, DOUBLE FLASH

IS3020, 12/24 VOLTS DC, DOUBLE FLASH

IS3210, 120 VOLTS AC, SINGLE FLASH

IS3220, 120 VOLTS AC, DOUBLE FLASH

IS3240, 240 VOLTS AC, DOUBLE FLASH

REPLACEMENT PARTS FOR IS3 SERIES STROBES

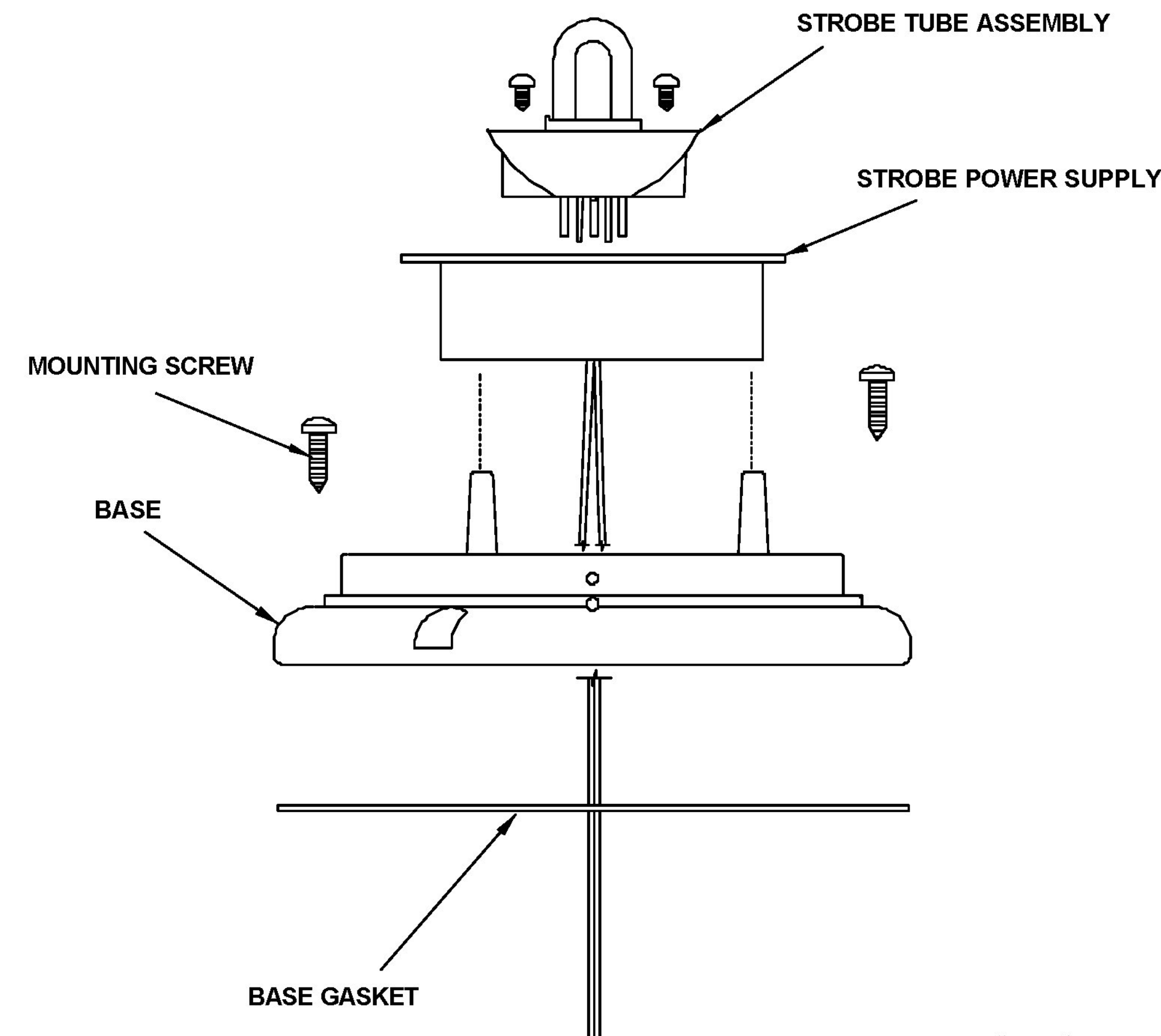
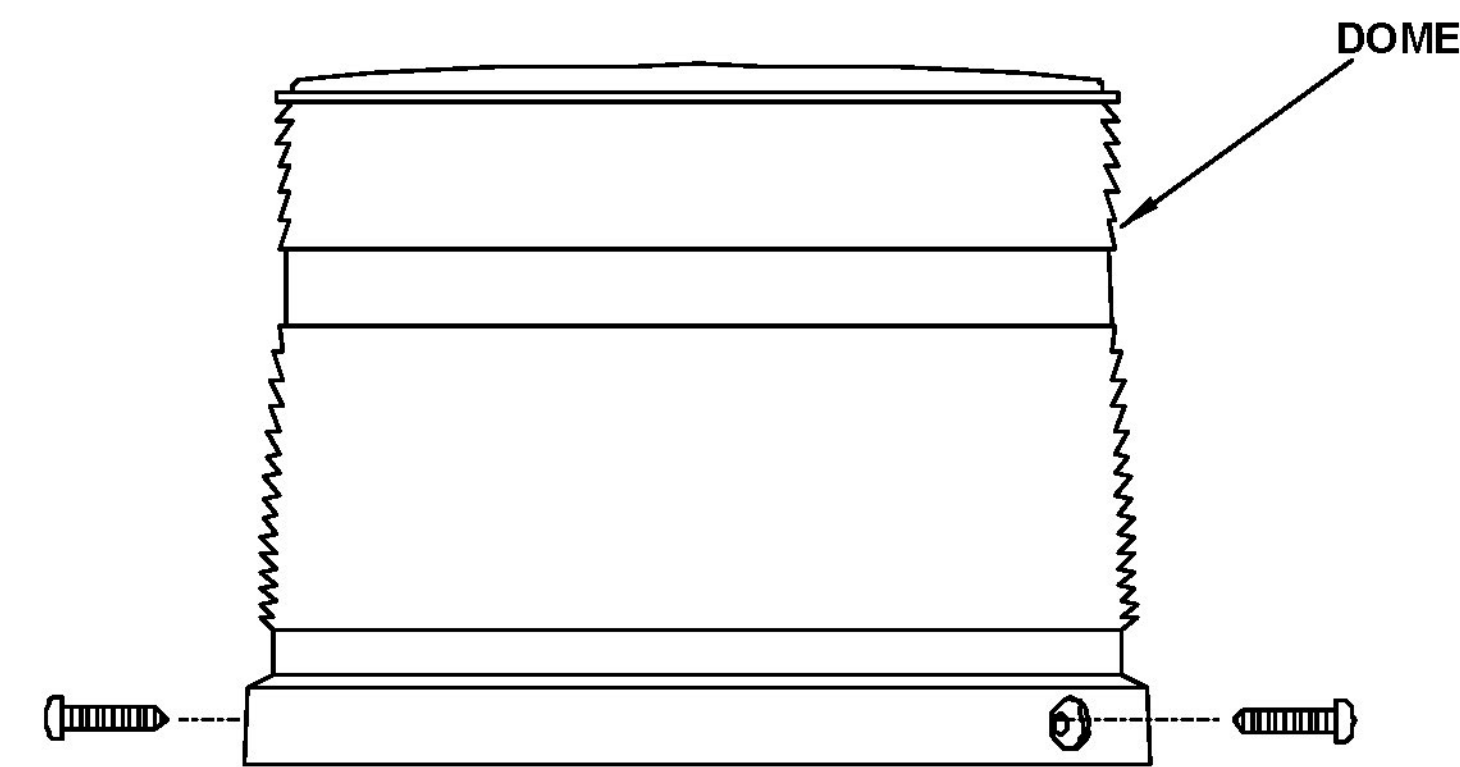

SEE OTHER SIDE OF PAGE FOR REPLACEMENT PARTS LISTING.

WARNING... DISCONNECT THE POWER SOURCE AND WAIT 10 MINUTES BEFORE INSTALLING OR SERVICING THE STROBE LIGHT.
--

IS3220 HR "High Dome / Red Lense"