

Pedestrian Signal Housing

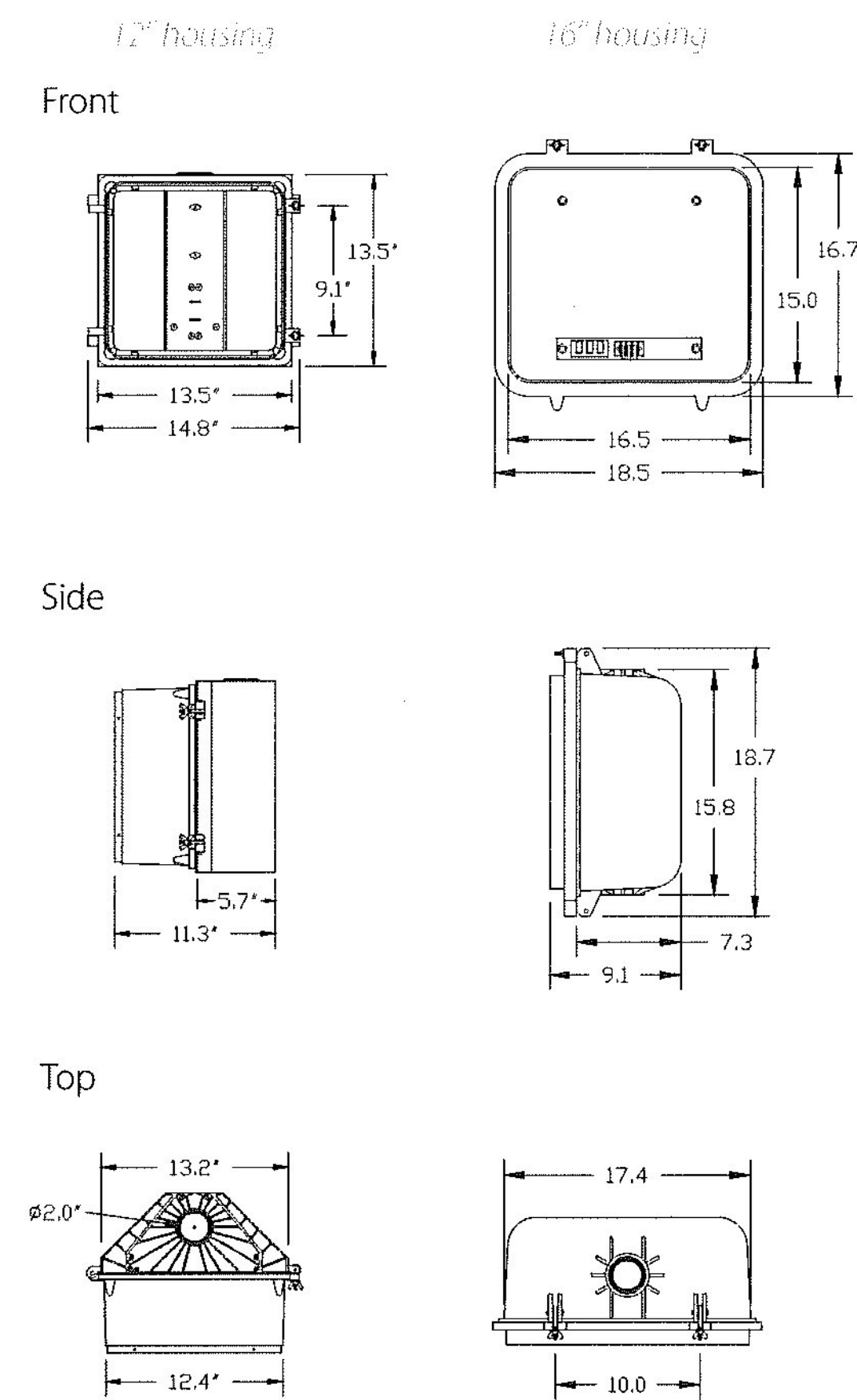

Dimensions rounded to the nearest 0.1"

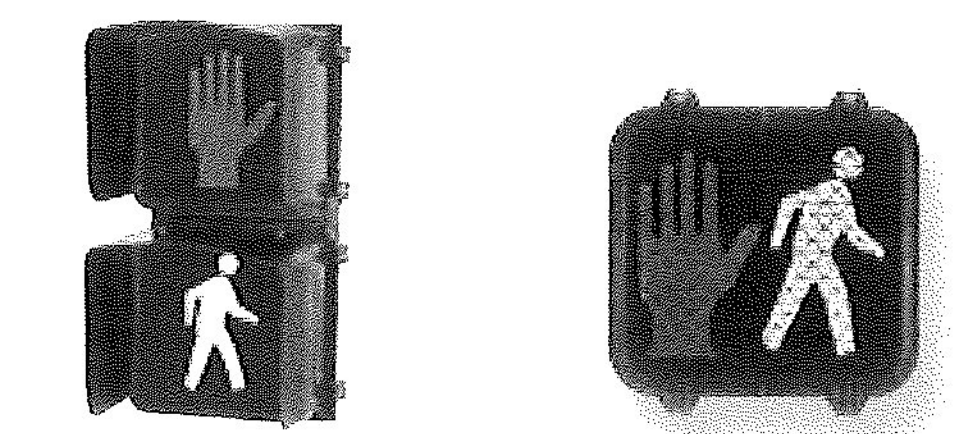

12" 2-section with tunnel visors
16" with Vantage Visor
Hand/Man modules (sold separately)



To learn more about McCain's Integrated Traffic Solutions, please contact 1-800-451-2709 or call (761) 727-8100

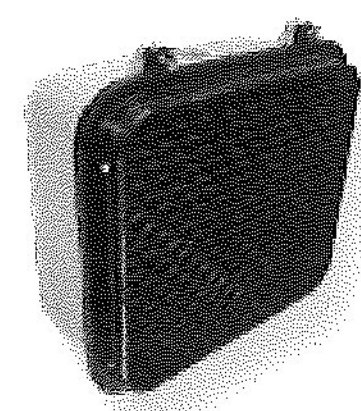

16" Vantage Visor (sold separately)

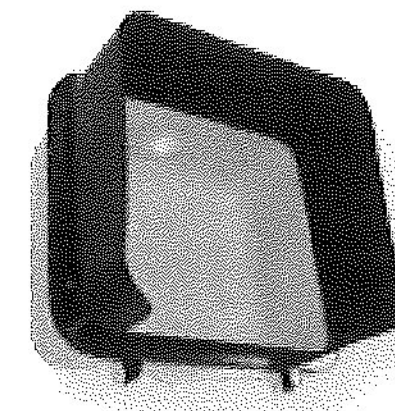

16" Tunnel visor (sold separately)



16" Clamshell mount (sold separately)

Standard Features

- Stainless steel hardware includes hinge pins (detent-type clevis or roll) and eye bolt/wing nuts (latch)
- Terminal block with quick-disconnect fittings on one side of each terminal position and screw clamps on the other side

General Specifications

Dimensions*:	12" Housing	16" Housing
Housing:	13.2" H x 13.2" W x 5.7" D	15.8" H x 17.4" W x 7.3" D
Door (incl. tabs):	13.5" H x 15.0" W x 5.6" D	18.7" H x 18.5" W x 1.8" D
Overall:	14.0" H x 15.0" W x 11.3" D	18.7" H x 18.5" W x 9.1" D
Material:	Polycarbonate: Ultraviolet and heat stabilized, flame retardant, permanently colored, 10% fiberglass reinforcement (12" standard, 16" optional) Aluminum: Type 360, reduced corrosion, increased powder coat adhesion	
Finish(es):	Polycarbonate: Colored resins integral to housing Aluminum: Powder coated	
Color(s):	Federal yellow, signal green, black, or custom colors	
Access:	Front door (1), 16": hinged top or bottom 12": hinged left or right	
Latching System:	Eye bolt assemblies	
Mounting:	Standard signal hardware	
Environmental:	Operating temperature: -37°C to +74°C Humidity: 0 to 95% (non-condensing)	
Shipping Weight:	12": Poly 5 lbs, Al 9 lbs	16": Poly 9 lbs, Al 10 lbs

Options

- Polycarbonate 10% fiberglass fill for added durability (optional on 16", standard on 12")
- Modules: LED or incandescent; international Hand/Man symbol, "WALK"/"DON'T WALK" words
- Visors: Vantage Visor (16" only), tunnel, or cap (12" only)
- Clamshell mount (16" only - housing available pre-drilled for mount)
- Custom terminal blocks
- Door hardware permanent (roll pins) or removable (clevis pins)

* Dimensions are approximate and vary based on material used

2365 OAK RIDGE WAY VISTA, CALIFORNIA 92081 USA WWW.MCCAIN-INC.COM

© 2009 McCain Inc. Updated 02/12/09. McCain reserves the right to change product specifications without notice. For the most up-to-date information, please contact McCain.