

Traffic Signal Housing

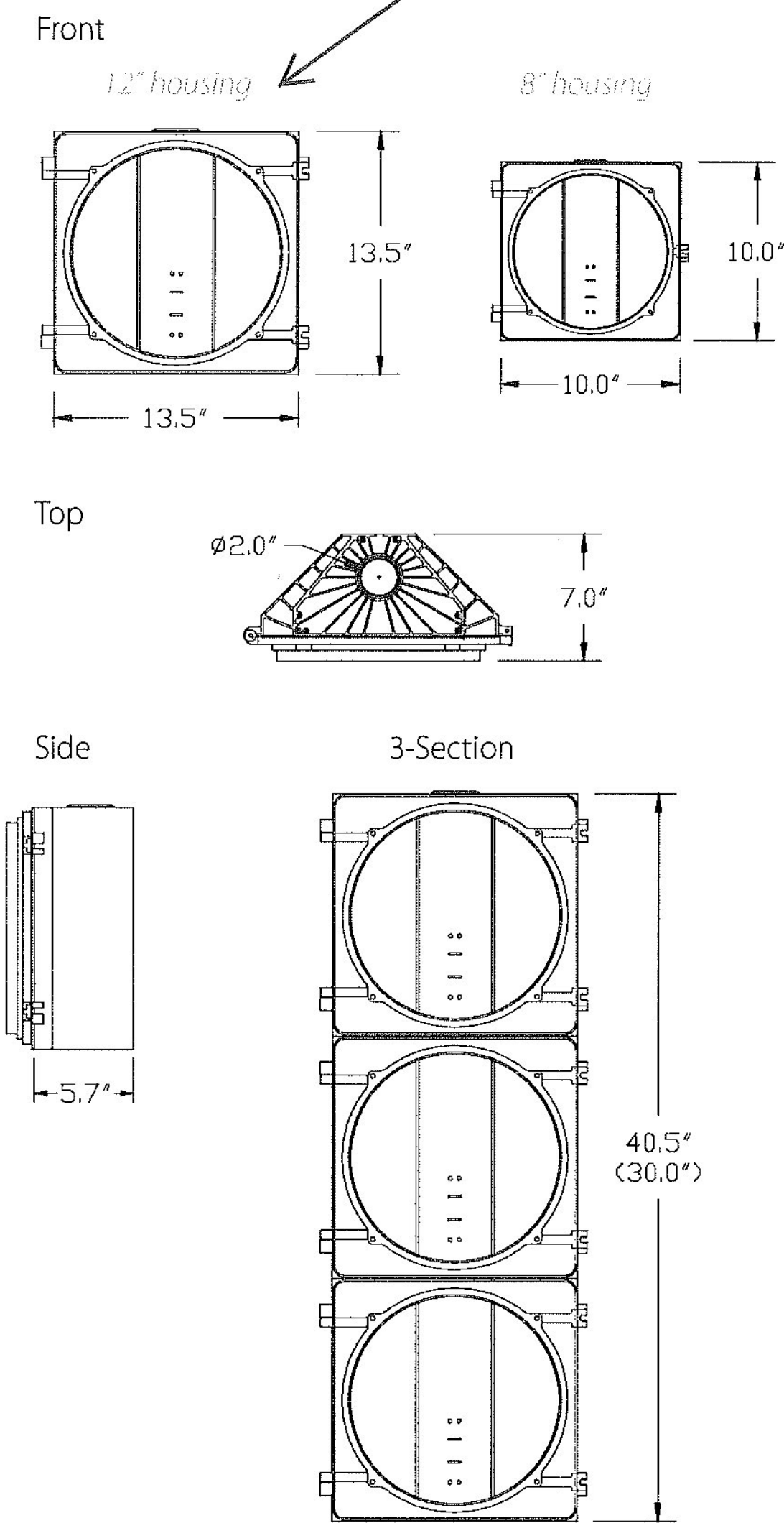

Dimensions are approximate and may vary.
 3-section 12" housing shown as an example configuration. 3-section 8" housing height dimensions is listed in parentheses.
 Depth for the 8" and 12" housings are approximately the same.
 Minor differences between the 8" and 12" may not be shown.

Standard Features

- Modular sections, one-piece, injection molded or cast
- 72-tooth serrated boss and reinforcing ribs, top and bottom
- Brass threaded inserts for visor attachment (4)
- Housings have a cast boss for mounting a 5 or 6-position terminal block; one side of terminal block with fast-on terminals, the other side with screw terminals
- The words red, amber, and green are cast next to each boss to identify light source lead wires
- 5 or 6-position terminal block installed in center section (1) (alternate mounting is available)
- Stainless steel door roll pins and eye bolt/wing nut assemblies
- Integral lugs on the housing and doors with stainless steel roll pins provide effective door hinges
- Weathertight E.P.D.M. rubber door gasket
- Aluminum and polycarbonate, and 8" and 12" housings can be mixed in one signal head

General Specifications

Dimensions:	8": 10.0" H x 10.0" W x 7.0" D
(1-section)	12": 13.5" H x 13.5" W x 7.0" D
Material:	Polycarbonate: Ultraviolet and heat stabilized, flame retardant, permanently colored, 10% fiberglass reinforcement Aluminum: Type 360, reduced corrosion, increased powder coat adhesion
Finish(es):	Polycarbonate: Colored resins integral to housing Aluminum: Powder coated
Color(s):	Federal yellow, signal green, black, or custom colors
Mounting:	2.0" hole top and bottom fits 1.5" NPT fittings
Environmental:	Operating temperature: -37°C to +74°C Humidity: 0 to 95% (non-condensing)
Shipping Weight:	Polycarbonate: 8" - 2.1 lbs 12" - 4.2 lbs (empty, 1-section) Aluminum: 8" - 4.0 lbs 12" - 7.8 lbs

Options

- Fiberglass-free polycarbonate
- Location, quantity, and type of terminal blocks
- Door mounting hardware: Push pin (removable) or roll pin (permanent)
- Visors
- Backplates
- Mounting: Various framework, orientation, and configurations
- Light Source: LED or incandescent
- High-performance (highly directional) signal version

Typical configurations

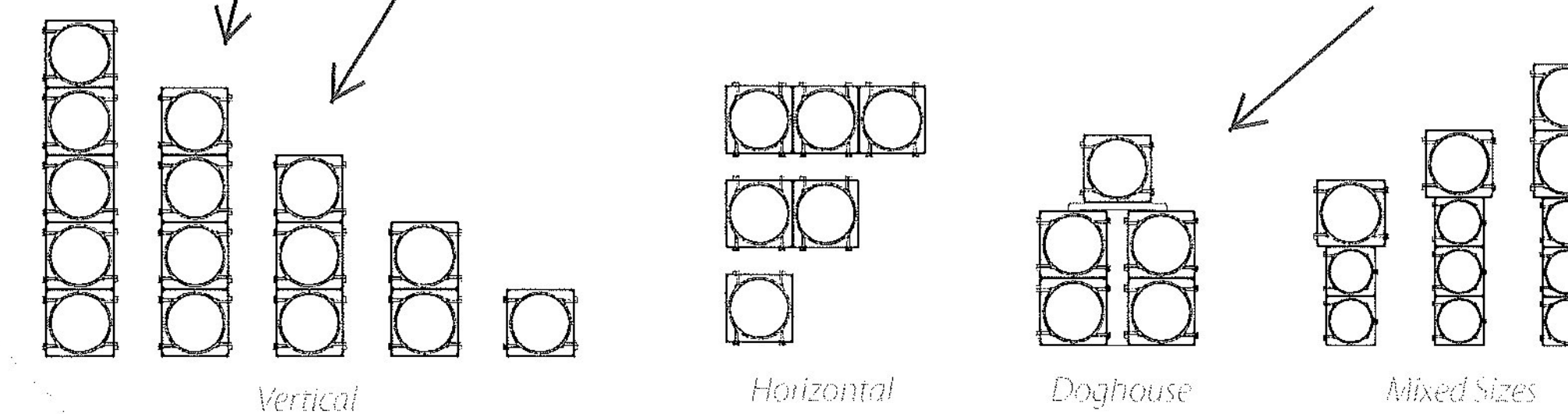

To learn more about McCain's Integrated Traffic Solutions, please contact info@mccain-inc.com or call (781) 227-8100

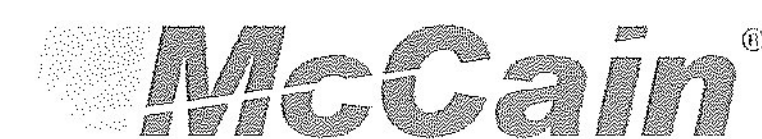

2365 OAK RIDGE WAY VISTA, CALIFORNIA 92081 USA WWW.MCCAIN-INC.COM

© 2009 McCain Inc. Updated 01/27/09. McCain reserves the right to change product specifications without notice. For the most up-to-date information, please contact McCain.