

CHEEKWALL REMOVAL LIMITS

SCALE: 1/2" = 1'-0"

NOTES:

1. 3" CLEAR, UNLESS OTHERWISE SPECIFIED ON THE PLANS.
2. 2'-2" SPLICE UNLESS OTHERWISE SPECIFIED ON THE PLANS.
3. 10" HOOK UNLESS OTHERWISE SPECIFIED ON THE PLANS.
4. SPLICE NEW CURTAIN WALL EXTENSION REINFORCING TO EXISTING EXPOSED CURTAIN WALL REINFORCING.
5. SEE SHEET 26 FOR SECTION A-A AND B-B.
6. SEE SHEET 16 FOR END CLOSURE POUR MASONRY AND REINFORCING PLAN.
7. ELEVATIONS ARE FOR INFORMATIONAL PURPOSES ONLY. FINAL FINISHED GRADES SHALL BE DETERMINED BY VTRANS AFTER EXISTING TOP OF DECK AND TOP OF BEAM ELEVATIONS ARE SURVEYED. SEE PROJECT NOTE 23 ON SHEET 3.

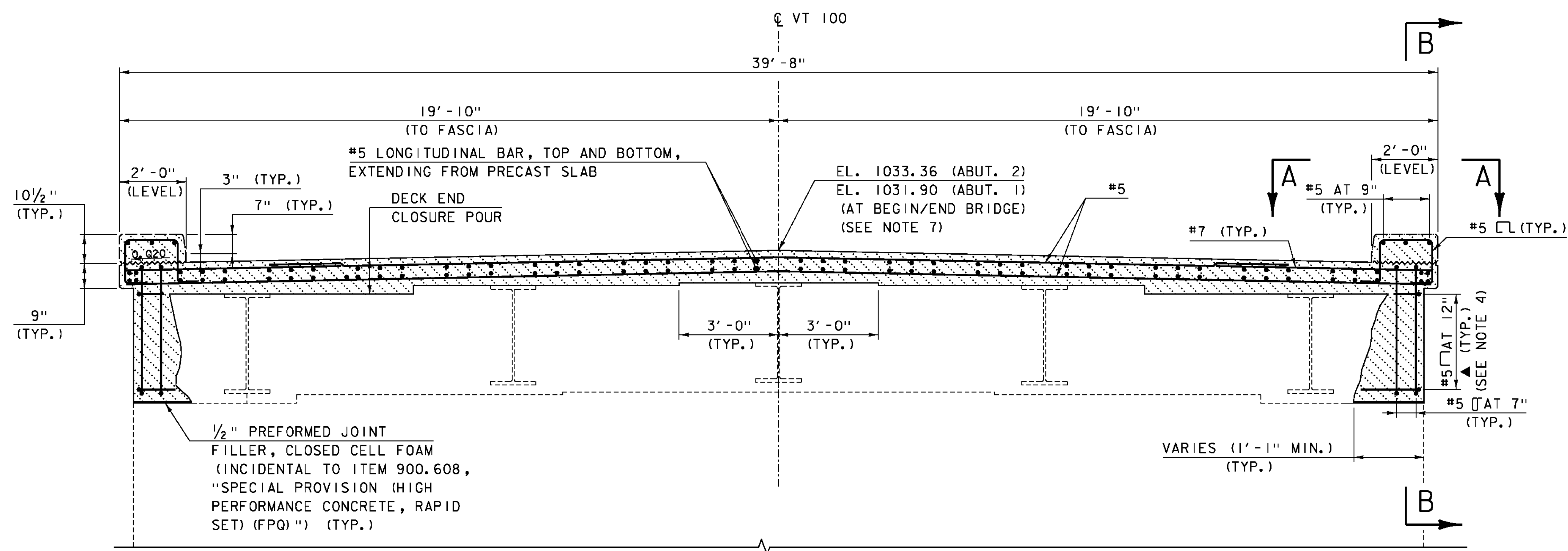

END CLOSURE POUR AND CURTAIN WALL MASONRY AND REINFORCING ELEVATION

SCALE: 1/2" = 1'-0"

- PARTIAL REMOVAL OF STRUCTURE
- REMOVAL OF CONCRETE OR MASONRY (SEE PROJECT NOTES 18 AND 19 ON SHEET 3).
- SPECIAL PROVISION (HIGH PERFORMANCE CONCRETE, RAPID SET) (FPQ)

PROJECT NAME:	LUDLOW	PLOT DATE:	8/3/2016
PROJECT NUMBER:	STP DECK(39)	DRAWN BY:	M. SMITH
FILE NAME:	z15bi09typ-99.dgn	DESIGNED BY:	S. BEAMONT
PROJECT LEADER:	J. BYATT	CHECKED BY:	A. GIRALDI
REMOVAL AND CURTAIN WALL DETAILS SHEET 1		SHEET 25 OF 42	



MODEL: Sheet15
CLD 15-0223