

How to use the P-51 Swift Lift Lifting Eye

When the P-51 Swift Lift Lifting Eye's position is changed from a diagonal pull to a vertical pull relative to the anchor axis, all movements are permissible, even with simultaneous rotation.

If the Swift Lift Anchor is positioned in a relatively thin panel, movement of the P-51 Swift Lift Lifting Eye under load from the vertical to an inclined position relative to the axis of the anchor (such as laying down a panel with edge inserts as shown in 1 below) is NOT PERMITTED due to excessive friction. This friction causes binding of the ball end of the P-51 Swift Lift Lifting Eye, and when the friction is overcome, the resultant sudden movement causes high impact stresses on the surrounding concrete. As an aid in reducing friction, apply a soap solution to the void formed by the recess plug.

The above maneuver can be accomplished when the proper rigging is used. The fleet angle between the slings must be between 90° and 120°. In this manner, precast concrete shapes can be placed from the vertical to the horizontal.

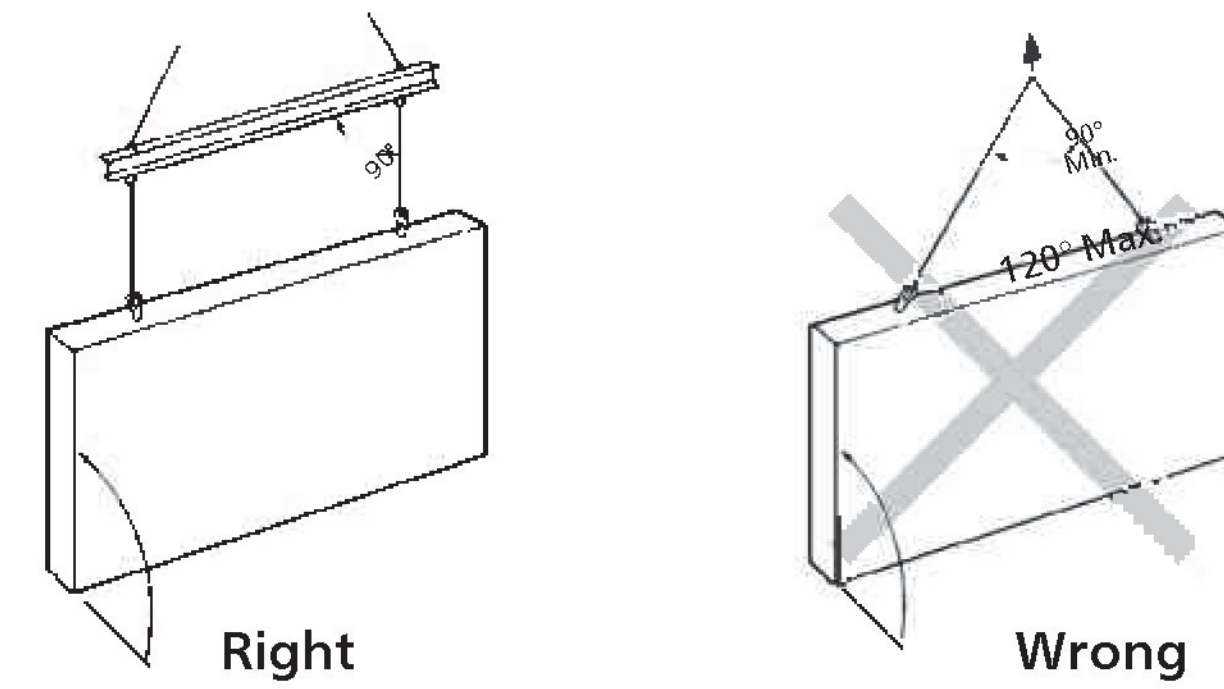

1 Maneuvering from horizontal to vertical with edge anchors

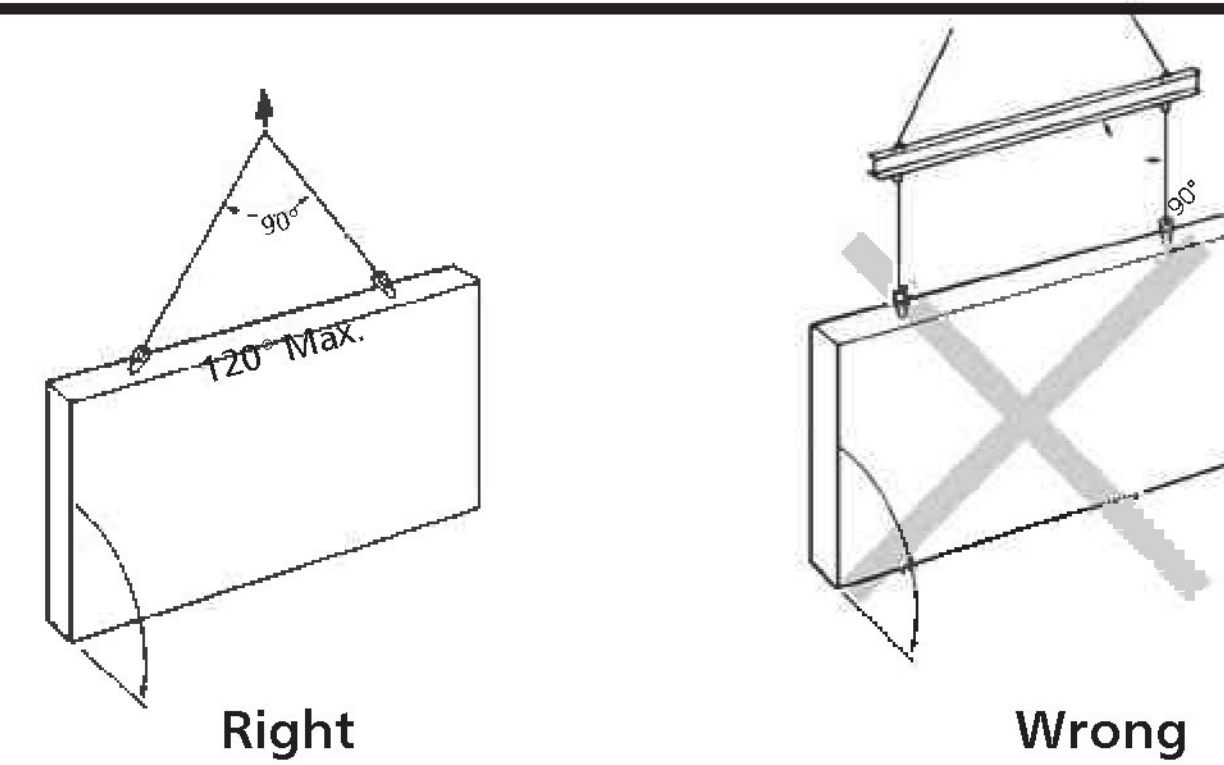

2 Maneuvering from vertical to horizontal with edge anchors

Note: To reduce friction between the Swift Lift Lifting Eye and the concrete, apply a soap solution to the cavity formed by the recess plug.

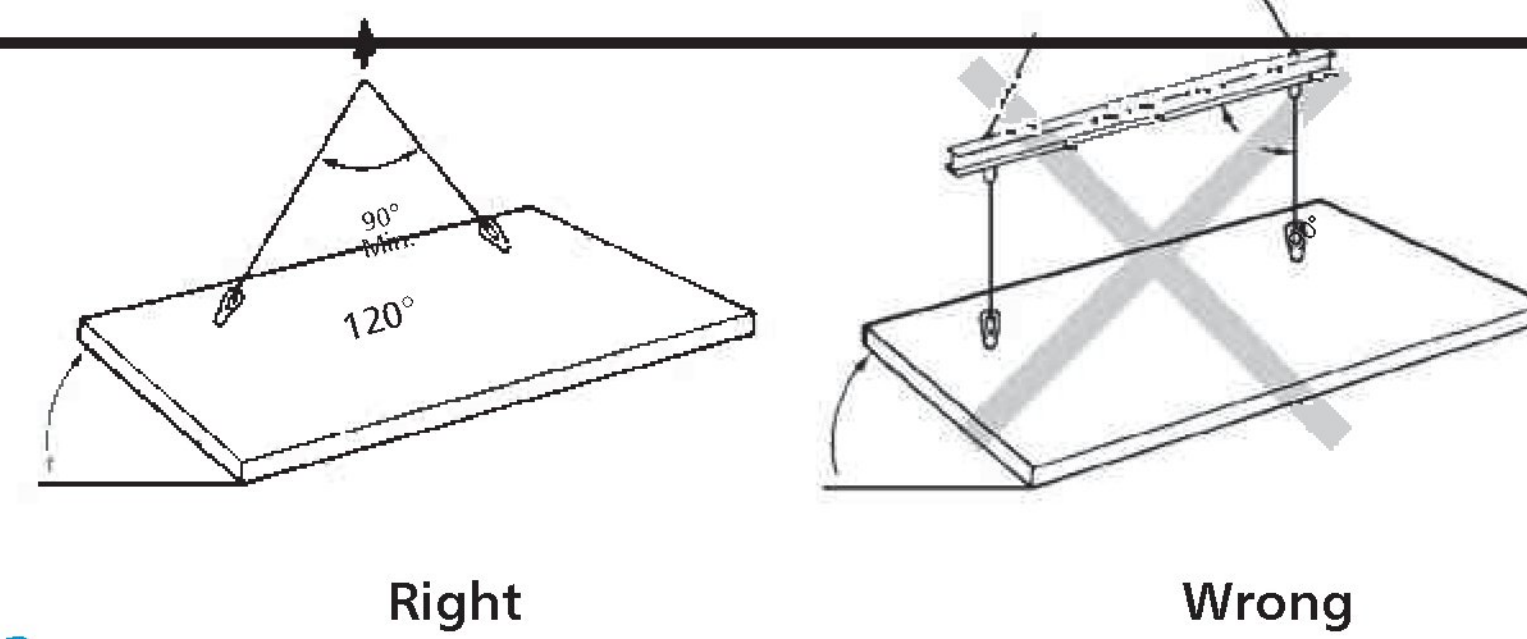

3 Maneuvering from horizontal to vertical with face anchors

Note: To reduce friction between the Swift Lift Lifting Eye and the concrete, apply a soap solution to the cavity formed by the recess plug.

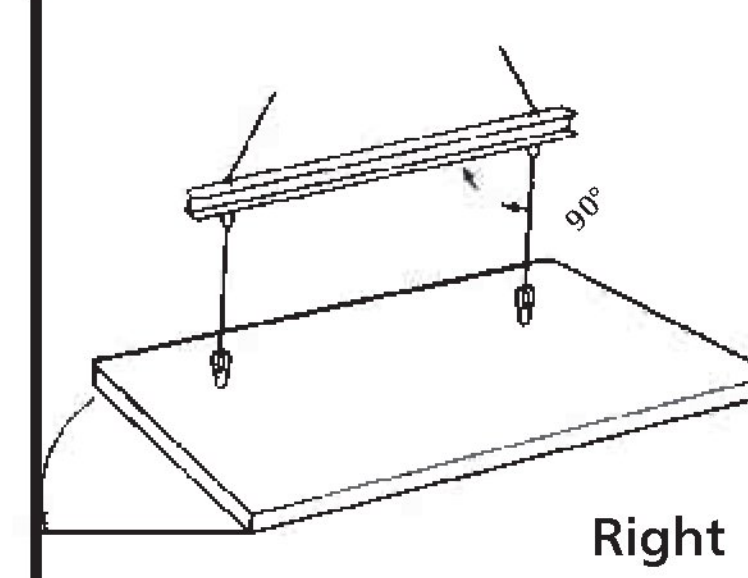

4 Maneuvering from vertical to horizontal with face anchors

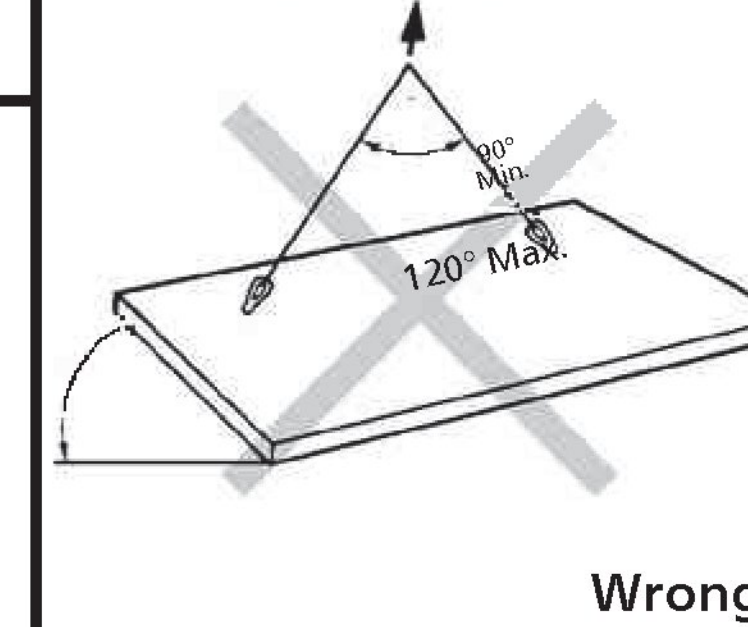

Vermont Agency of Transportation

RECEIVED

CK'D BY NVDB, JW, KM, TM OK'D BY JG

March 21, 2017

RESUBMIT No Approved

BY K. Higgins DATE 03/23/17