

Swift Lift System

The Swift Lift System is a quick connect-disconnect system that allows precast concrete elements to be handled repeatedly, with speed, safety and economy. The System is a non-welded system and void of threaded connections. The quality, reusable Swift Lift Lifting Eye's heavy duty construction will provide years of good service.

The Swift Lift System is available with safe load ratings of 1, 2, 4, 8 and 20 tons. Each component is clearly marked with its maximum safe working load. The System is extremely versatile and can be utilized for vertical and diagonal pulls. It can be used to lift concrete elements from a horizontal to a vertical position without the aid of a tilting table.

P-50 Swift Lift Universal Lifting Eye

The Swift Lift Universal Lifting Eye (P-50) consists of a flat-sided, spherical lifting body and a high strength bail. The lifting body has a T-shaped slot that permits rapid attachment and release of the head on Swift Lift Anchors.

The design of the P-50 Universal Lifting Eye permits the bail to freely rotate 180°, while the complete lifting eye may rotate through a 360° arc. This design feature allows precast concrete elements to be turned, tilted and/or rotated under load.

Dayton Superior does not recommend the use of this lifting eye for edge lifting of thin precast concrete panels.

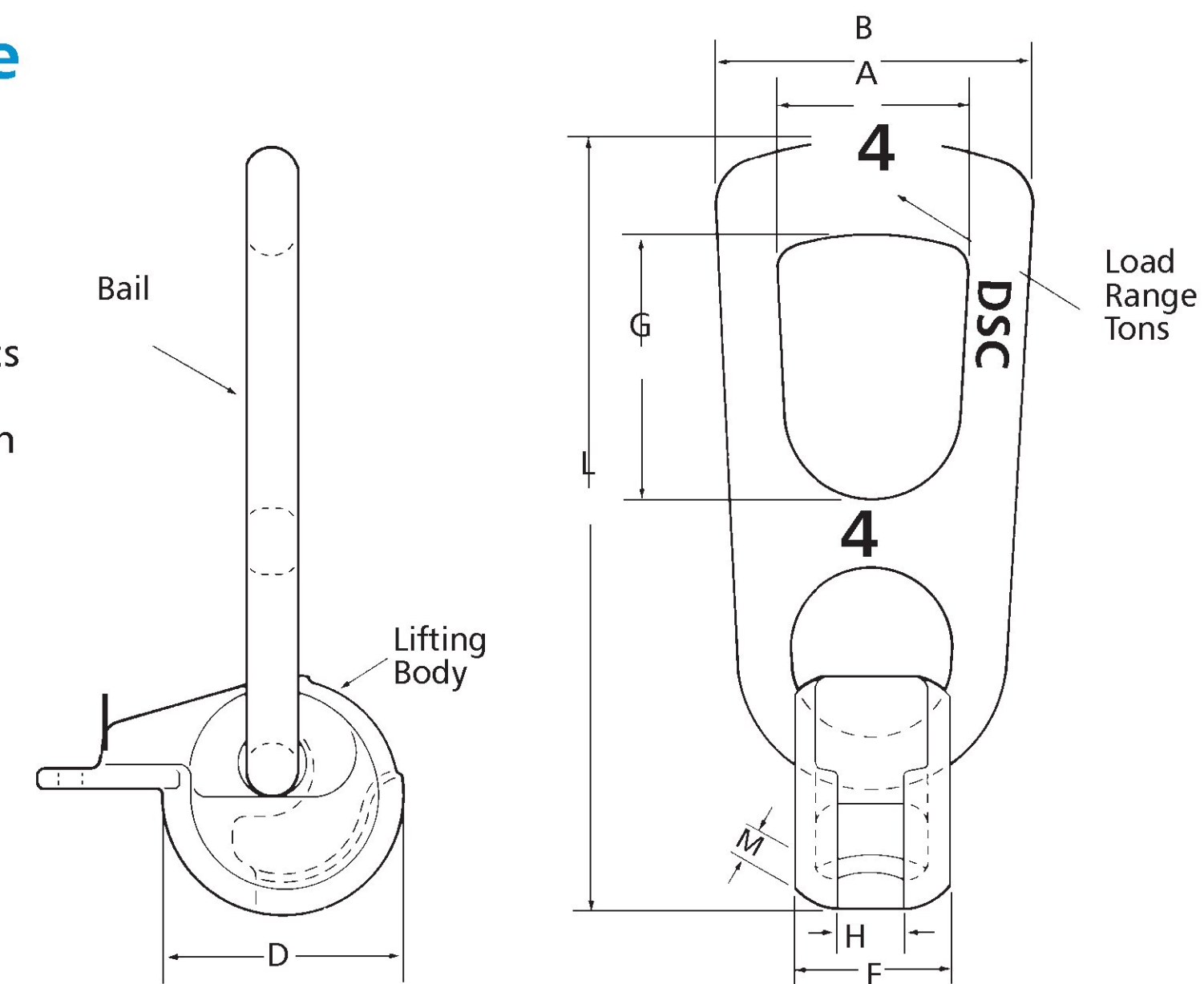

P-50 Swift Lift Universal Lifting Eye Dimensions						
Rated Load Tons	A	B	D	F	G	L
1	1.87"	2.95"	2.20"	1.26"	2.80"	7.40"
2	2.34"	3.58"	2.68"	1.61"	3.41"	9.06"
4	2.76"	4.65"	3.46"	2.22"	3.46"	11.14"
8	3.47"	6.30"	4.41"	2.83"	4.52"	15.79"
20	4.18"	7.09"	6.00"	4.29"	5.31"	20.00"



The rated load provides a factor of safety of approximately 5 to 1 (ultimate to rated load).

Inspection and Maintenance

The P-50 Universal Lifting Eye may be subjected to wear, misuse, overloading and other factors that can affect the lifting eye's rated load. Therefore, it is imperative that the lifting eye be user-inspected at least once a month to determine its general condition and degree of wear.

During the user's monthly inspection, the lifting eye should be checked for evidence of heat application. If evidence of heat application is found, the unit must be scrapped. Check for a bent or twisted bail and discard all units found to have these flaws. Also, check to make certain that the bail rotates freely in all directions.

At least once every three months, dimensions "H" and "M" on each unit should be checked. The upper limits are shown in the chart. If either of these limits is exceeded, the P-50 Universal Lifting Eye must be removed from service and destroyed.

The proper method for scrapping a lifting eye is to cut through the bail with a cutting torch to render the unit useless as a lifting device.

No repairs or welding to the P-50 Swift Lift Universal Lifting Eye are permitted.

Limiting Dimensions on P-50 Swift Lift Universal Lifting Eye		
Rated Load (Tons)	H Maximum Width	M Minimum Thickness
1	0.512"	0.217"
2	0.709"	0.236"
4	0.984"	0.315"
8	1.260"	0.472"
20	1.811"	0.709"