

ABUTMENT TYPICAL
NOT TO SCALE

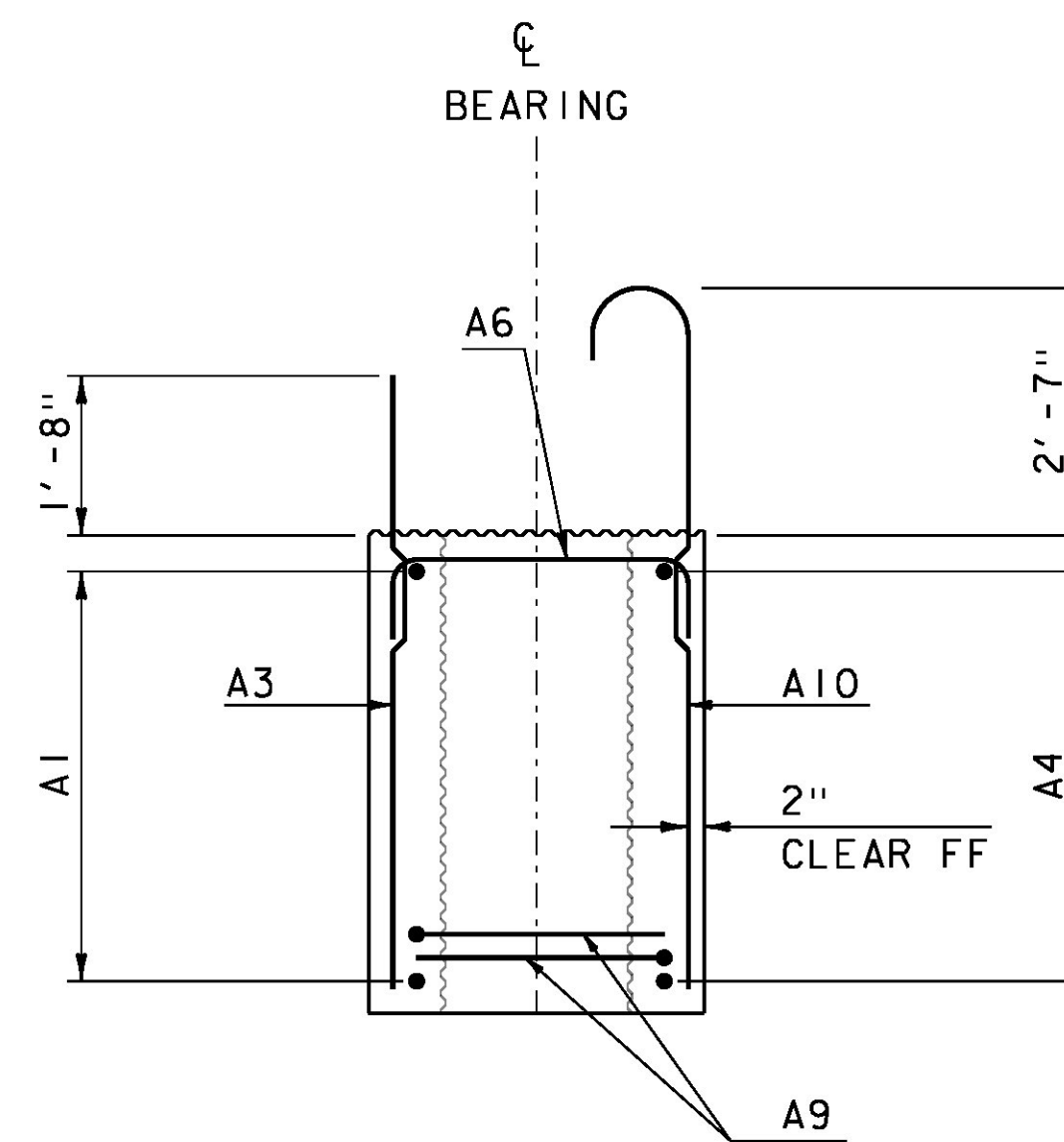

ABUTMENT REINFORCING
AT BRIDGE SEAT
NOT TO SCALE

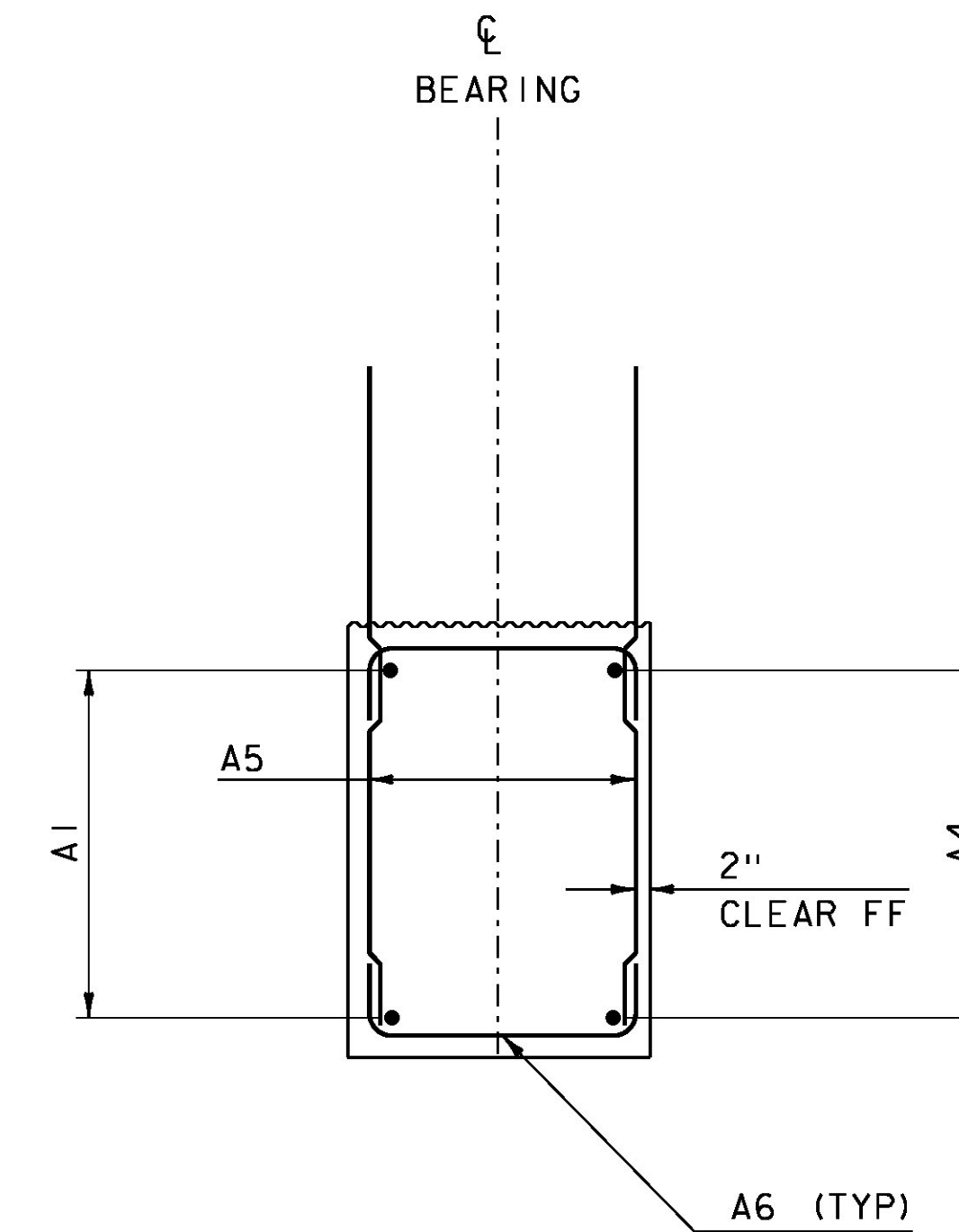

ABUTMENT REINFORCING
AT CAST IN PLACE CHEEK WALL
NOT TO SCALE

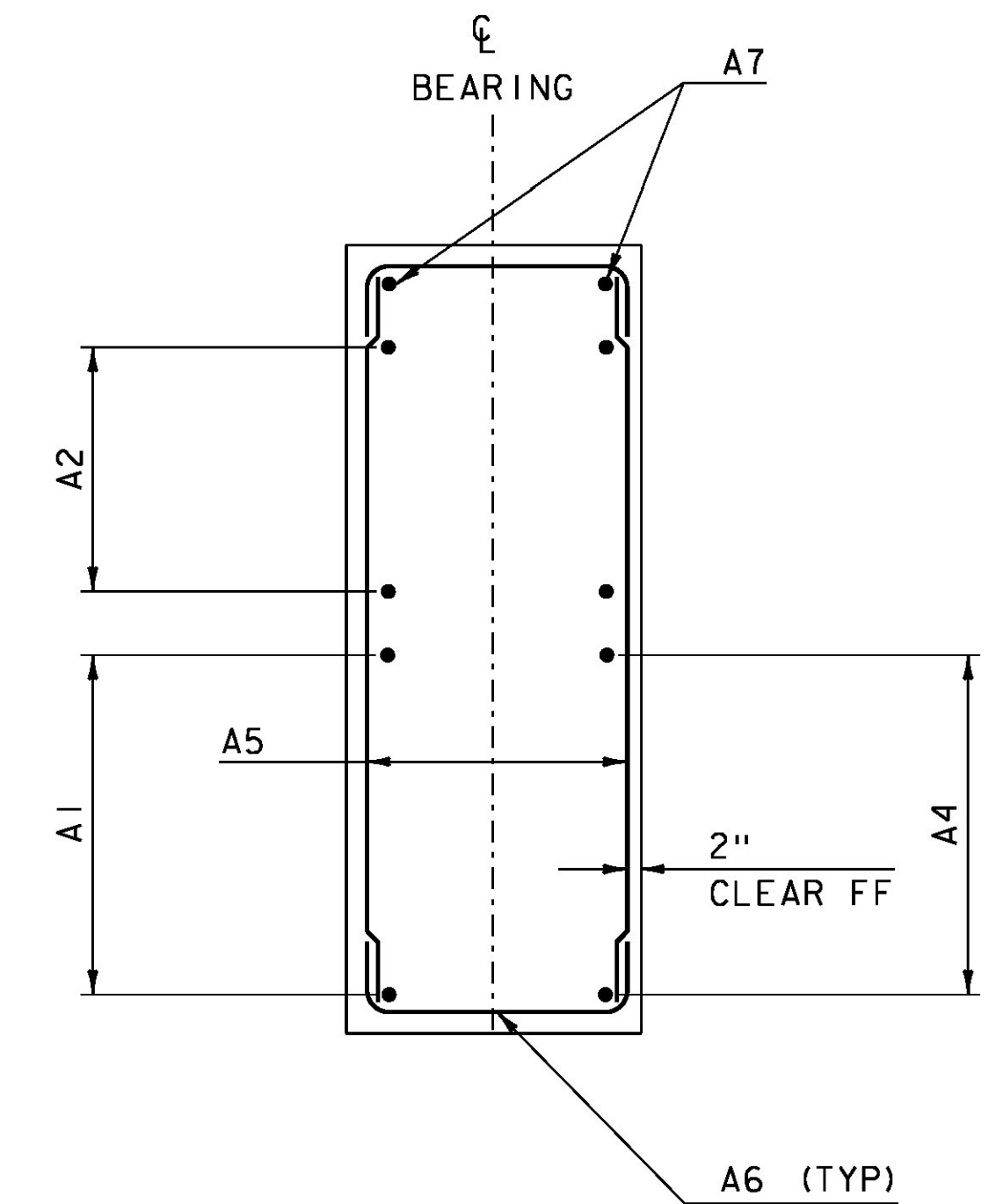

ABUTMENT REINFORCING
AT PRECAST CHEEK WALL
NOT TO SCALE

NOTE:

- SEE ABUTMENT REINFORCING SHEET FOR REINFORCING TABLE.
- 10 MIL POLYETHYLENE SHEET WILL BE CONSIDERED INCIDENTAL TO PAY ITEM 501.34 "HIGH PERFORMANCE CONCRETE, CLASS B (FPQ) "

NOTE:

NF = NEAR FACE
FF = FAR FACE
EF = EACH FACE
3" CLEAR, UNLESS OTHERWISE SPECIFIED ON THE PLANS.

 SPECIAL PROVISION (HIGH PERFORMANCE CONCRETE, RAPID SET)

PROJECT NAME:	STRAFFORD
PROJECT NUMBER:	BF 0177(10)
FILE NAME: si3j088subl.dgn	PLOT DATE: 31-AUG-2016
PROJECT LEADER: K. HIGGINS	DRAWN BY: J. GRIGAS
DESIGNED BY: J. GRIGAS	CHECKED BY: G. LAROCHE
ABUTMENT TYPICALS SHEET	SHEET 28 OF 52