

SLIGHTLY BURY EDGE OF MESH, RECESS ROCK ANCHORS ACCORDINGLY

ROCK ANCHOR AT STABILIZATION MESH BOUNDARY DETAIL

6

N.T.S.

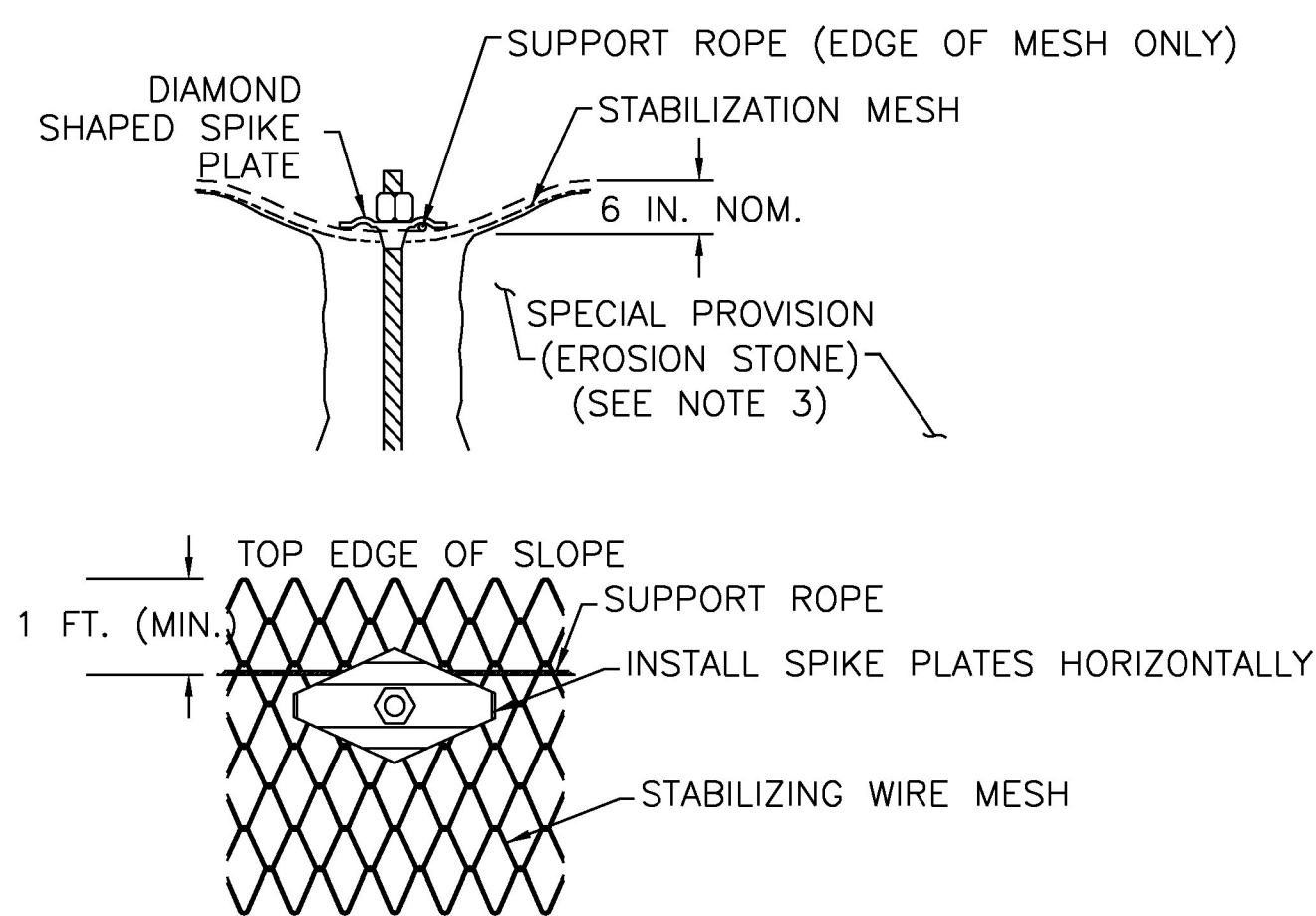

ROCK ANCHOR HEAD DETAIL

7

N.T.S.

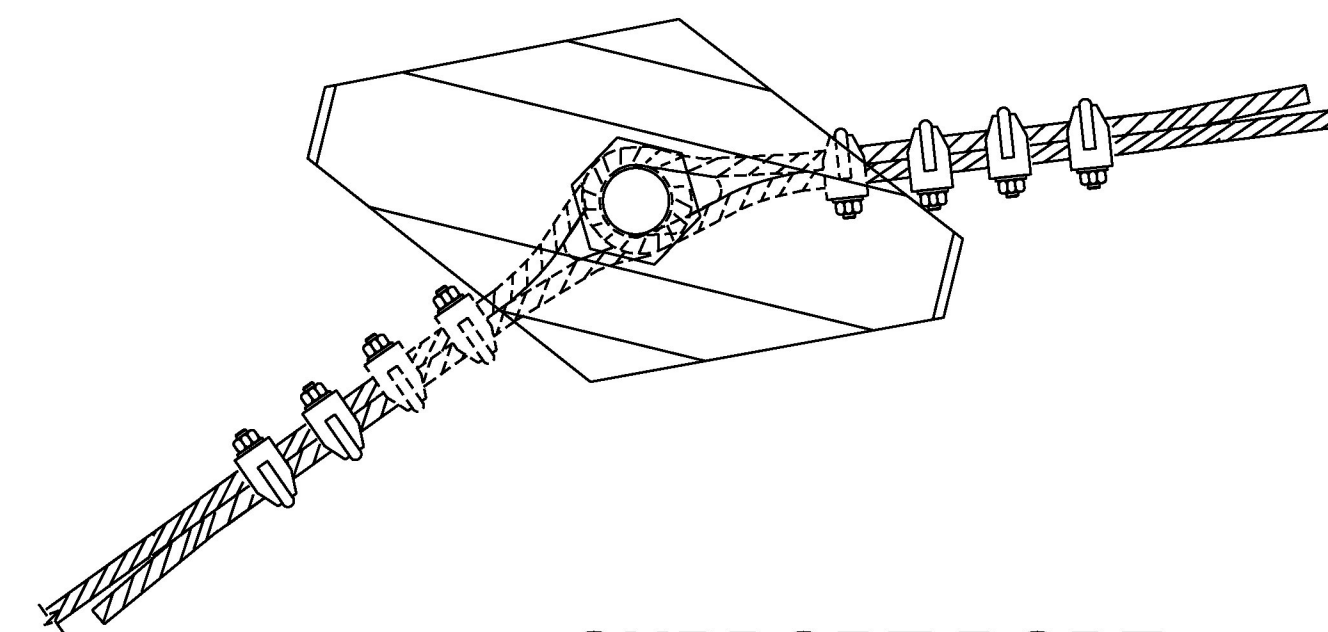

SUPPORT ROPE TERMINATION DETAIL

8

N.T.S.

NOTES

- 1.) LOOPS SHALL BE PLACED UNDER SPIKE PLATE PRIOR TO PRE-TENSIONING.
- 2.) REFER TO DETAIL 9 FOR WIRE ROPE ANCHOR LOOP.

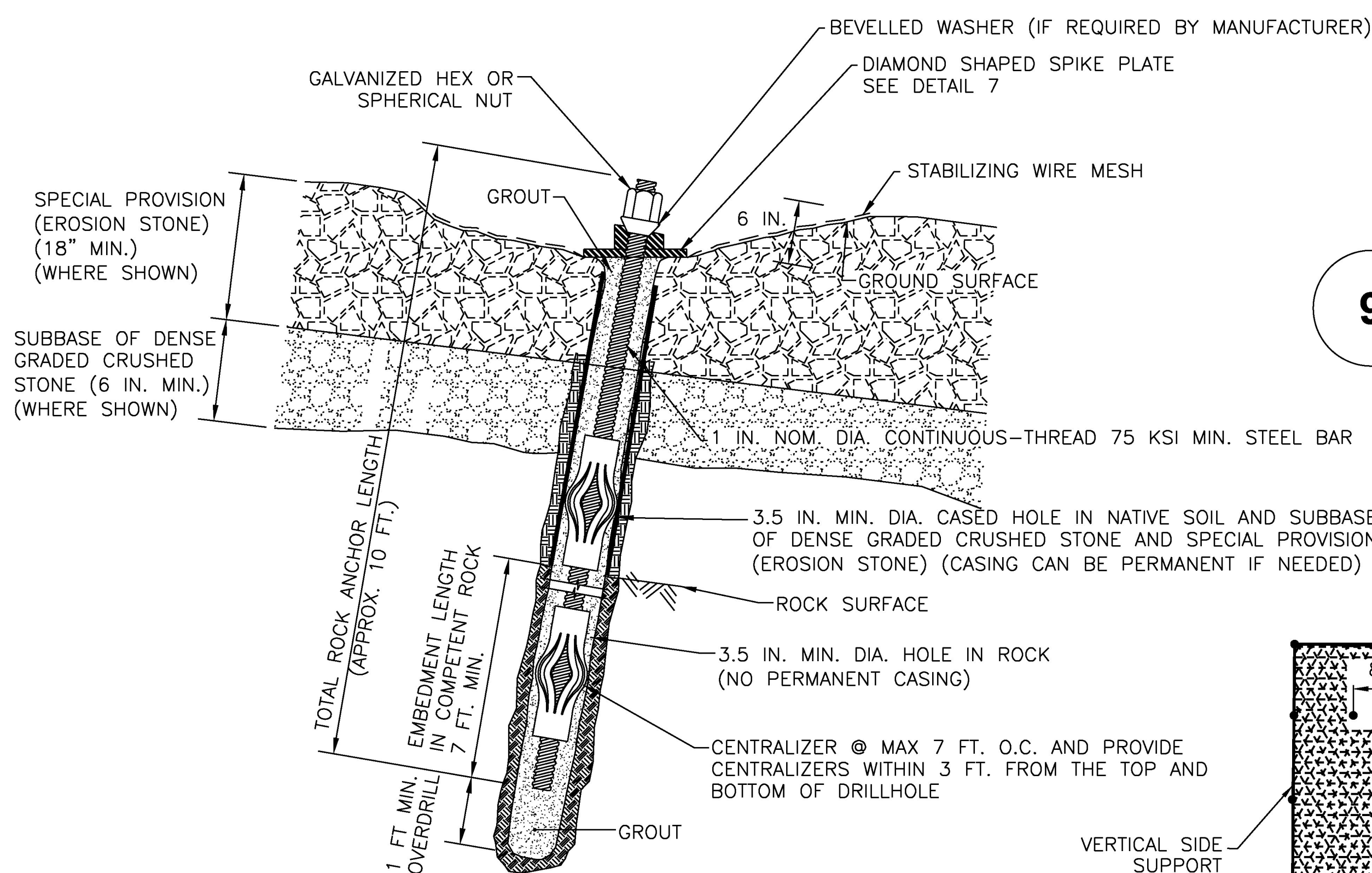

MINIMUM OF 12 FT OF BOND BELOW THE UNDISTURBED GROUND SURFACE, IF BEDROCK NOT REACHED

TYPICAL ROCK ANCHOR DETAIL FOR ANCHORING IN ROCK

10

N.T.S.

NOTES

- 1.) DESIGN LOAD OF ROCK ANCHORS IS 11 KIPS (50 KN). TORQUE TENSION ANCHORS AS DIRECTED BY ENGINEER (TYP. 369 FT-LBS.) WHERE PLATES BEAR DIRECTLY ON ROCK, TORQUE NUT TO 150 FT.-LBS.

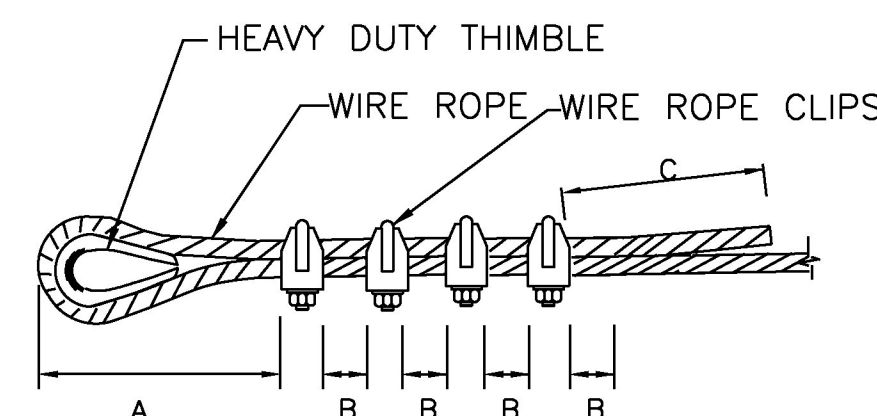

WIRE ROPE ANCHOR LOOP DETAIL

9

N.T.S.

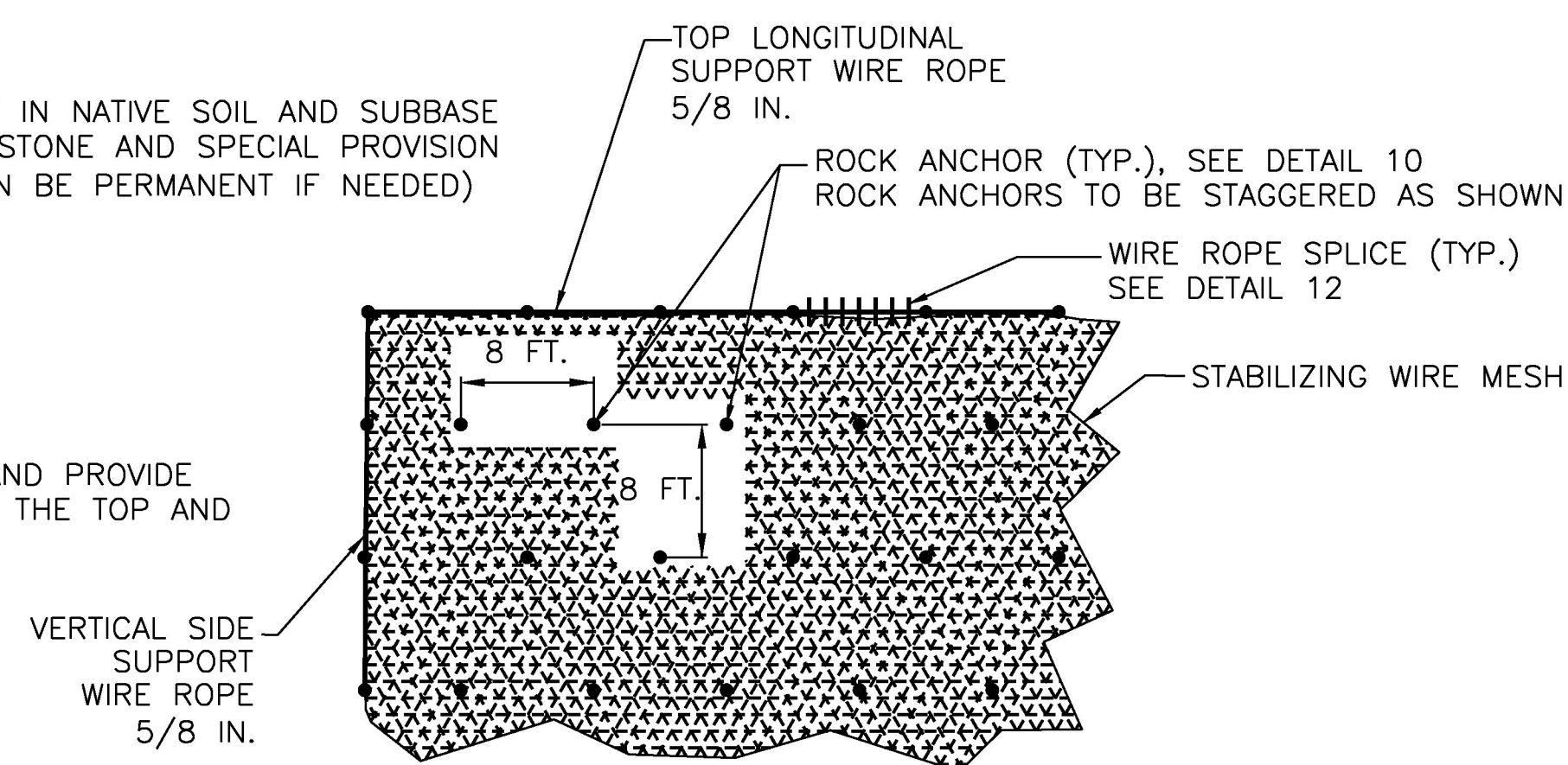

11

TYPICAL ROCK ANCHOR PATTERN

N.T.S.

NOTES

- 1.) FOR CONNECTION BETWEEN ROCK ANCHOR, ROPE NET/WIRE MESH, AND SUPPORT ROPE, SEE DETAIL 7.

ROPE DIAMETER	MINIMUM WIRE ROPE CLIP SIZE		MINIMUM WIRE ROPE CLIP QUAN.	A		B		C		TORQUE REQUIRED		
	IN.	mm		IN.	mm	IN.	mm	FT-LBS.	N*m			
5/8	16	5/8	16	4	9	229	4	102	6	152	95	128.8

12

WIRE ROPE SPLICING DETAIL

N.T.S.



PROJECT NAME: PLYMOUTH
PROJECT NUMBER: ER 0149(6)

FILE NAME: I13874IIA007.dgn
PROJECT LEADER: J. SANTACRUCE
DESIGNED BY: GOLDER ASSOCIATES
SLOPE STABILITY DETAILS 2

PLOT DATE: 5/17/2016
DRAWN BY: GOLDER ASSOC.
CHECKED BY: GOLDER ASSOC.
SHEET 32 OF 68