

**D3-1**

LOCATION: NORTHFIELD:  
STA. 185+93, RT  
COLOR: WHITE BORDER AND TEXT (RETROREFLECTIVE)  
GREEN BACKGROUND (RETROREFLECTIVE)  
MATERIAL: 0.125" FLAT SHEET ALUMINUM

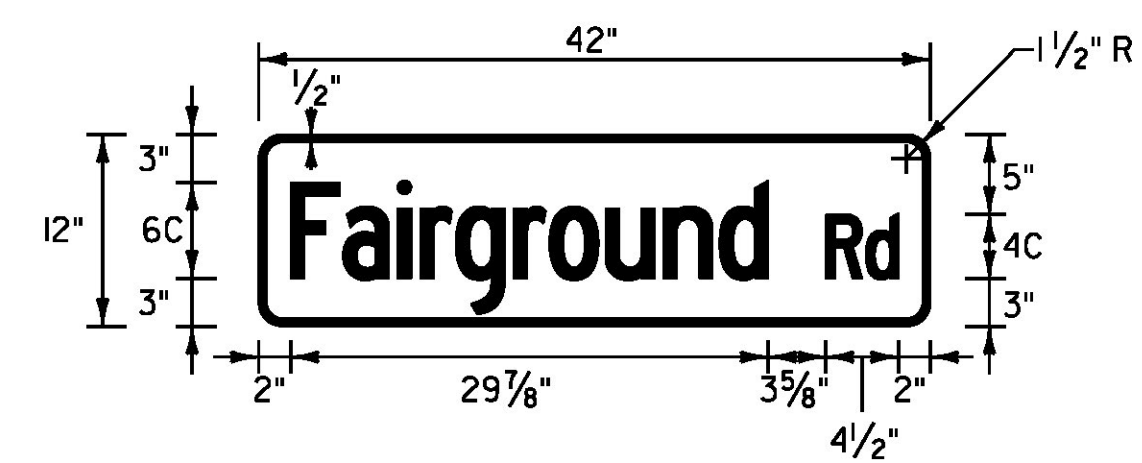

**D3-1**

LOCATION: NORTHFIELD:  
STA. 189+66, LT  
COLOR: WHITE BORDER AND TEXT (RETROREFLECTIVE)  
GREEN BACKGROUND (RETROREFLECTIVE)  
MATERIAL: 0.125" FLAT SHEET ALUMINUM

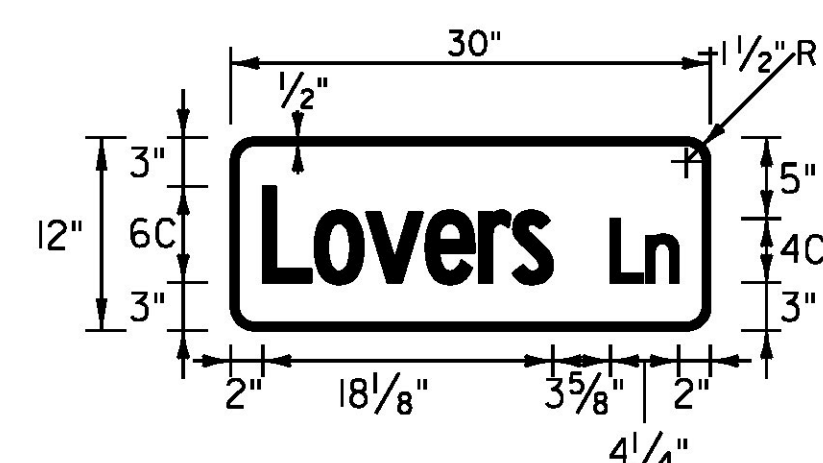

**D3-1**

LOCATION: NORTHFIELD:  
STA. 191+72, RT  
COLOR: WHITE BORDER AND TEXT (RETROREFLECTIVE)  
GREEN BACKGROUND (RETROREFLECTIVE)  
MATERIAL: 0.125" FLAT SHEET ALUMINUM

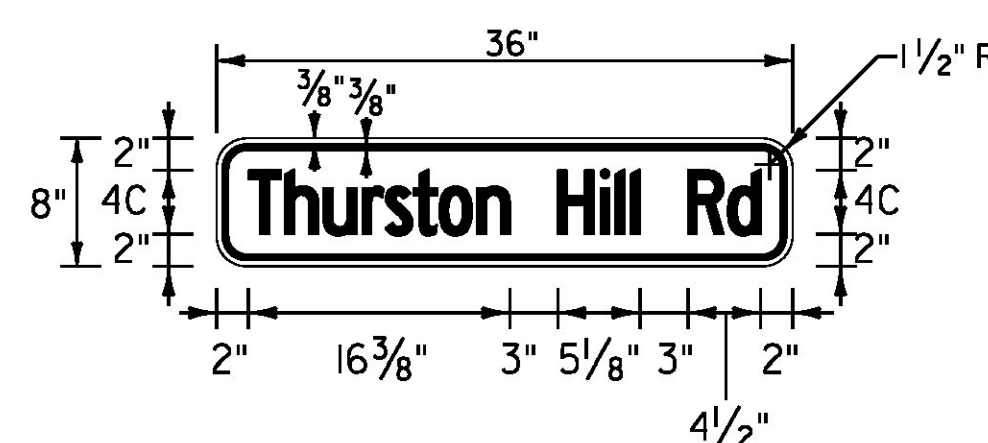

**W16-8P**

LOCATION: ROXBURY:  
STA. 135+52, RT  
STA. 145+75, LT  
COLOR: BLACK BORDER AND TEXT (RETROREFLECTIVE)  
YELLOW BACKGROUND (RETROREFLECTIVE)  
MATERIAL: 0.080" FLAT SHEET ALUMINUM

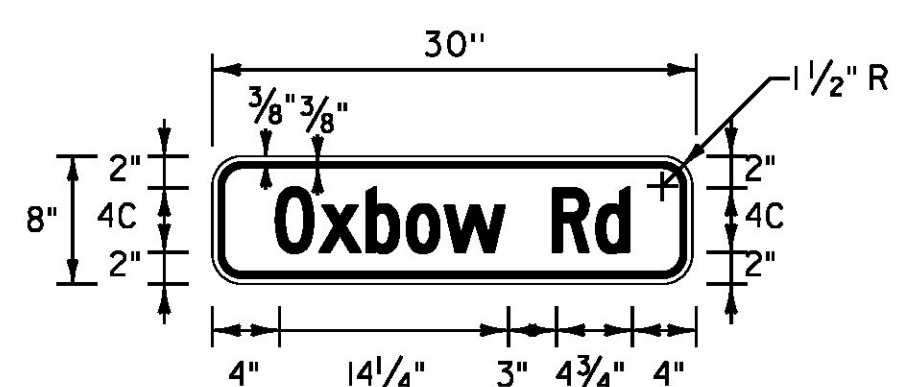

**W16-8P**

LOCATION: ROXBURY:  
STA. 141+75, RT  
STA. 156+00, LT  
COLOR: BLACK BORDER AND TEXT (RETROREFLECTIVE)  
YELLOW BACKGROUND (RETROREFLECTIVE)  
MATERIAL: 0.080" FLAT SHEET ALUMINUM

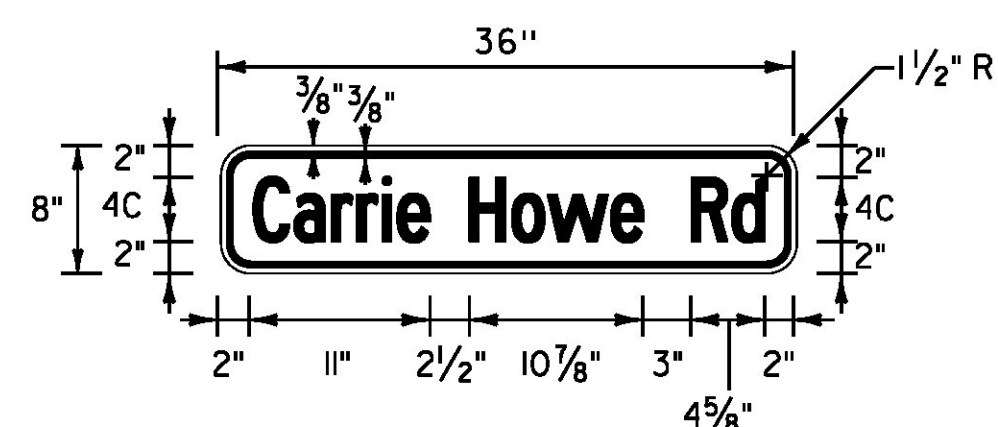

**W16-8P**

LOCATION: ROXBURY:  
STA. 157+85, RT  
STA. 171+06, LT  
COLOR: BLACK BORDER AND TEXT (RETROREFLECTIVE)  
YELLOW BACKGROUND (RETROREFLECTIVE)  
MATERIAL: 0.080" FLAT SHEET ALUMINUM

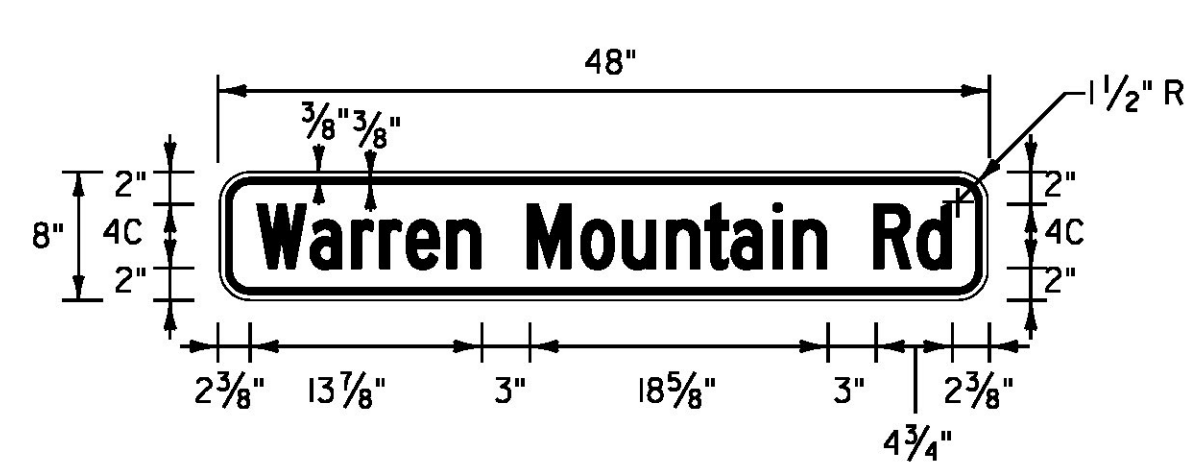

**W16-8P**

LOCATION: ROXBURY:  
STA. 244+18, RT  
STA. 256+30, LT  
COLOR: BLACK BORDER AND TEXT (RETROREFLECTIVE)  
YELLOW BACKGROUND (RETROREFLECTIVE)  
MATERIAL: 0.080" FLAT SHEET ALUMINUM

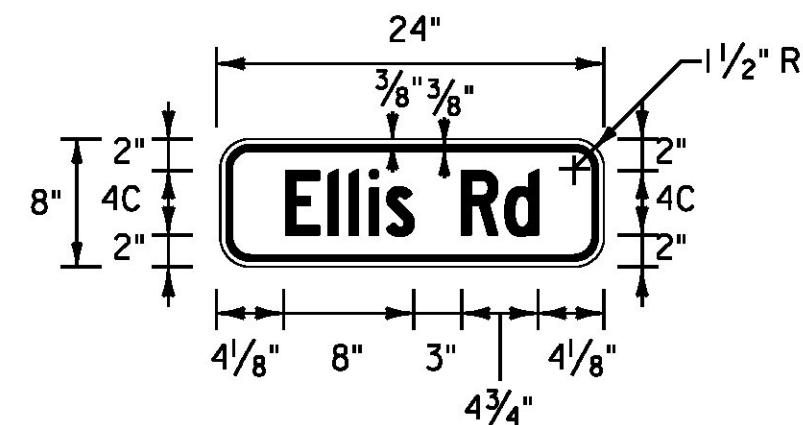

**W16-8P**

LOCATION: ROXBURY:  
STA. 275+76, RT  
STA. 283+93, LT  
COLOR: BLACK BORDER AND TEXT (RETROREFLECTIVE)  
YELLOW BACKGROUND (RETROREFLECTIVE)  
MATERIAL: 0.080" FLAT SHEET ALUMINUM

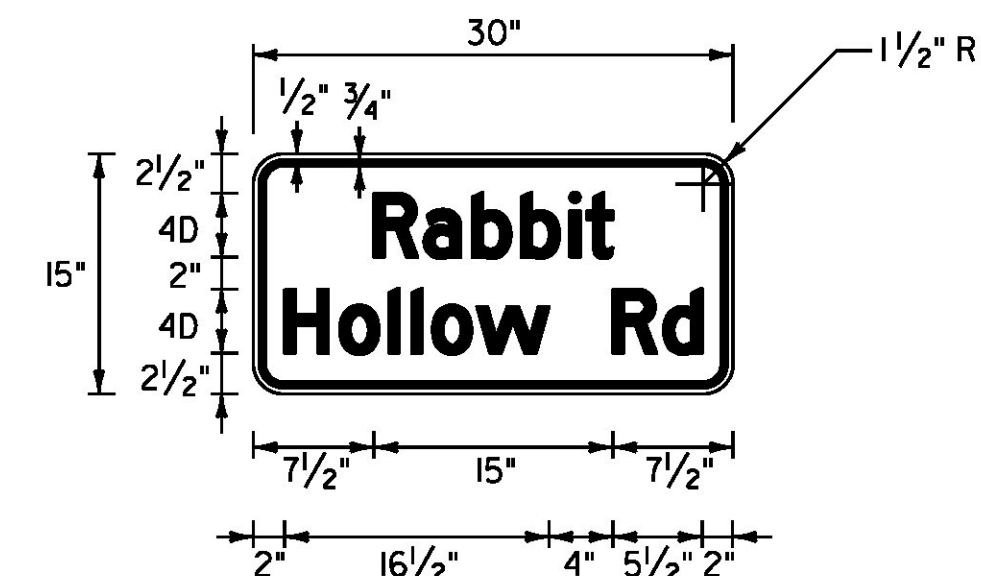

**W16-8aP**

LOCATION: NORTHFIELD:  
STA. 5+06, LT  
COLOR: BLACK BORDER AND TEXT (RETROREFLECTIVE)  
YELLOW BACKGROUND (RETROREFLECTIVE)  
MATERIAL: 0.080" FLAT SHEET ALUMINUM

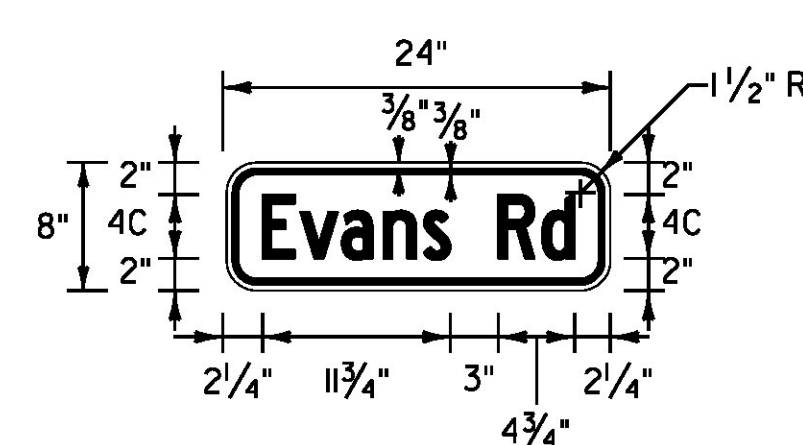

**W16-8P**

LOCATION: NORTHFIELD:  
STA. 1+80, RT  
STA. 7+60, LT  
COLOR: BLACK BORDER AND TEXT (RETROREFLECTIVE)  
YELLOW BACKGROUND (RETROREFLECTIVE)  
MATERIAL: 0.080" FLAT SHEET ALUMINUM

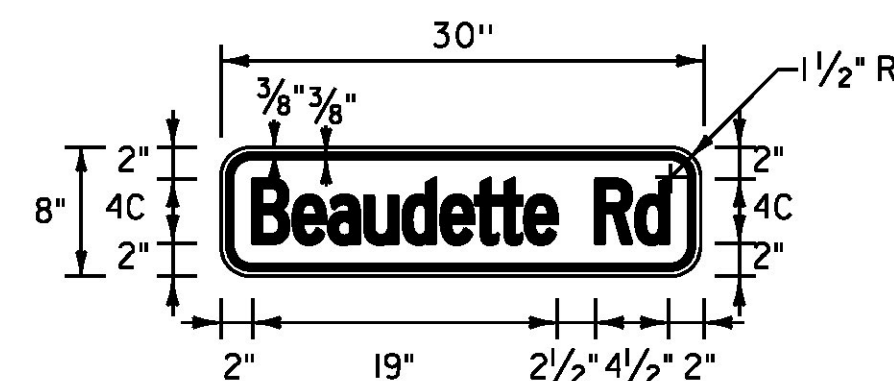

**W16-8P**

LOCATION: NORTHFIELD:  
STA. 12+50, LT  
COLOR: BLACK BORDER AND TEXT (RETROREFLECTIVE)  
YELLOW BACKGROUND (RETROREFLECTIVE)  
MATERIAL: 0.080" FLAT SHEET ALUMINUM

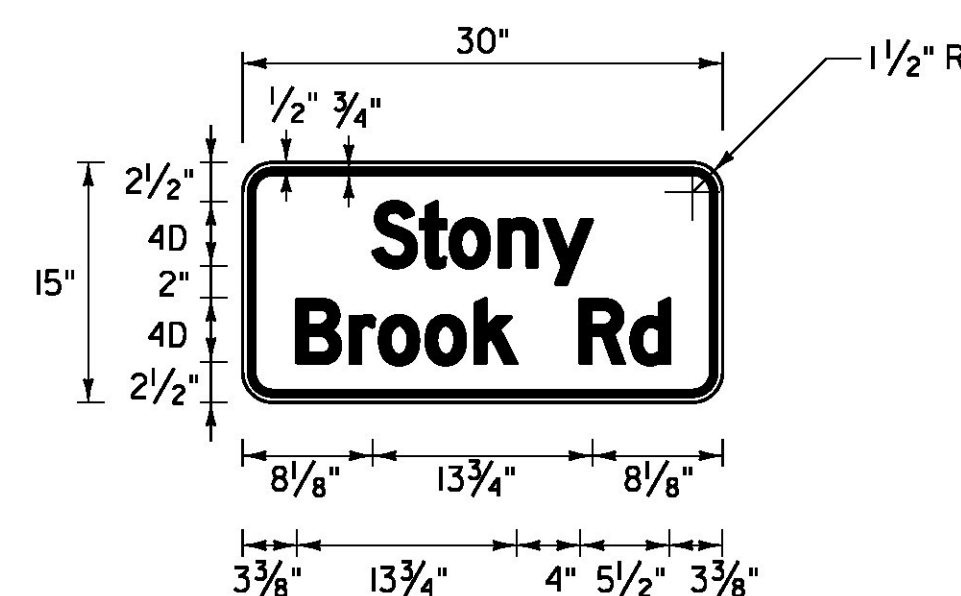

**W16-8aP**

LOCATION: NORTHFIELD:  
STA. 151+00, RT  
COLOR: BLACK BORDER AND TEXT (RETROREFLECTIVE)  
YELLOW BACKGROUND (RETROREFLECTIVE)  
MATERIAL: 0.080" FLAT SHEET ALUMINUM

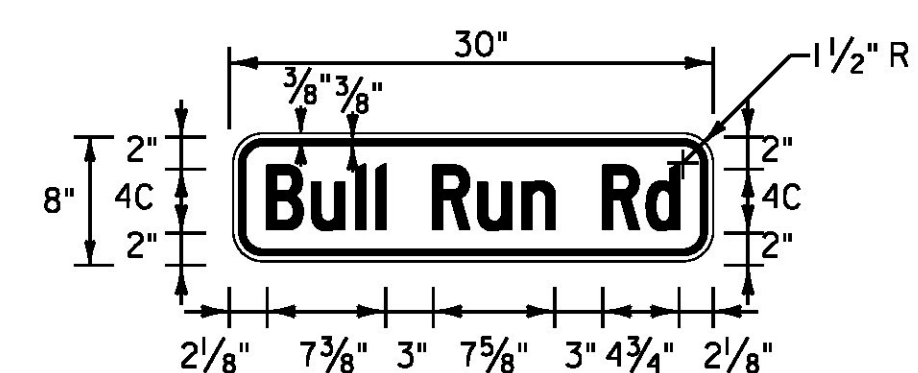

**W16-8P**

LOCATION: NORTHFIELD:  
STA. 169+75, LT  
COLOR: BLACK BORDER AND TEXT (RETROREFLECTIVE)  
YELLOW BACKGROUND (RETROREFLECTIVE)  
MATERIAL: 0.080" FLAT SHEET ALUMINUM

NOTE: SEE TRAFFIC SIGN NOTES ON SHEETS 162-188.

PROJECT NAME: ROXBURY-NORTHFIELD  
PROJECT NUMBER: ER STP 0187(13)

FILE NAME: z13cl84+yp.dgn PLOT DATE: 5/25/2016  
PROJECT LEADER: M. FOISY DRAWN BY: G. BARRETT  
DESIGNED BY: G. BURGMEIER CHECKED BY: G. EDWARDS  
TRAFFIC SIGN DETAIL SHEET 2 SHEET 190 OF 476

