

FILE	
ES6006.1	
REVISIONS	
06-28-2011	TJF/XRL
12-28-2011	TJF/XRL
07-03-2013	XRL/GRC

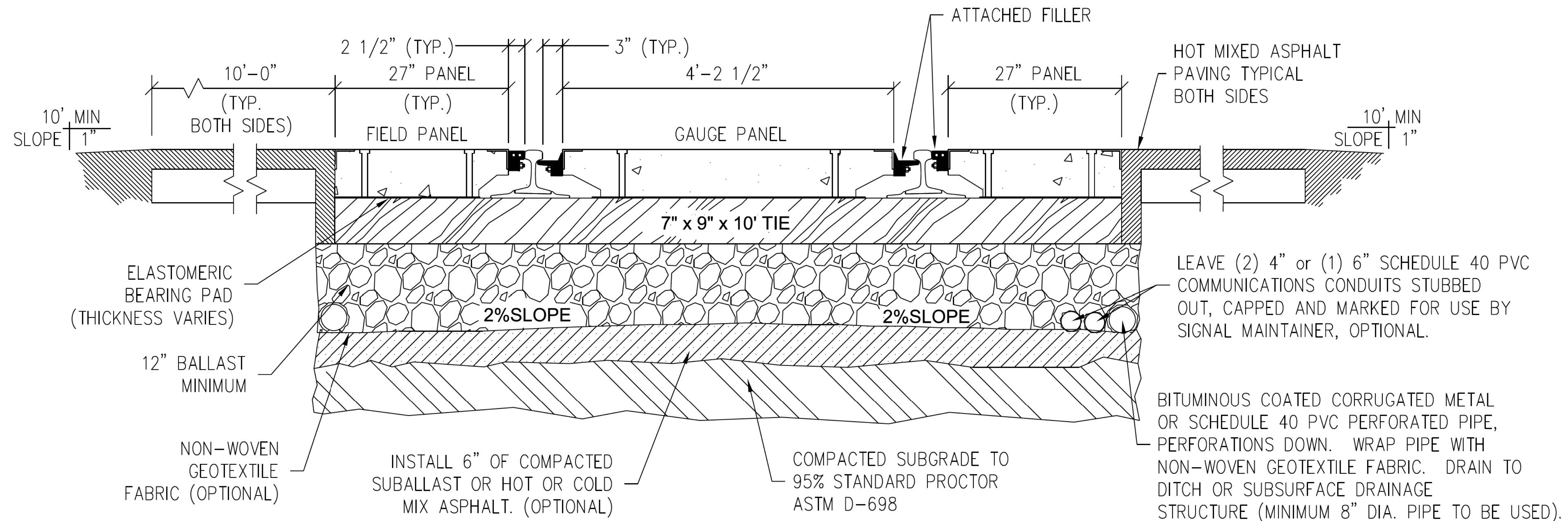

NOTE:
Concrete Crossing Panels will be Omni ECR Type or approved equal accepted by the AVP of Engineering Services. Reference Omni part No. 10-1469-00 ECR