

FILE	
ES6005.1	
REVISIONS	
07-03-2013	XRL/GRC

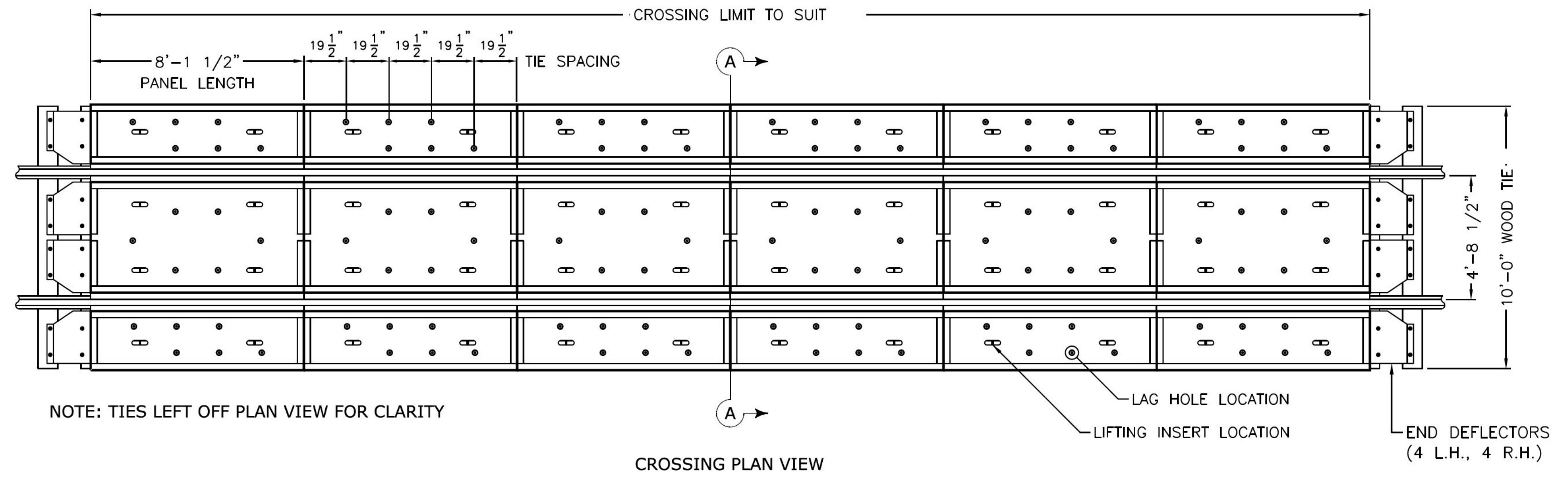

NOTE: TIES LEFT OFF PLAN VIEW FOR CLARITY

CROSSING PLAN VIEW

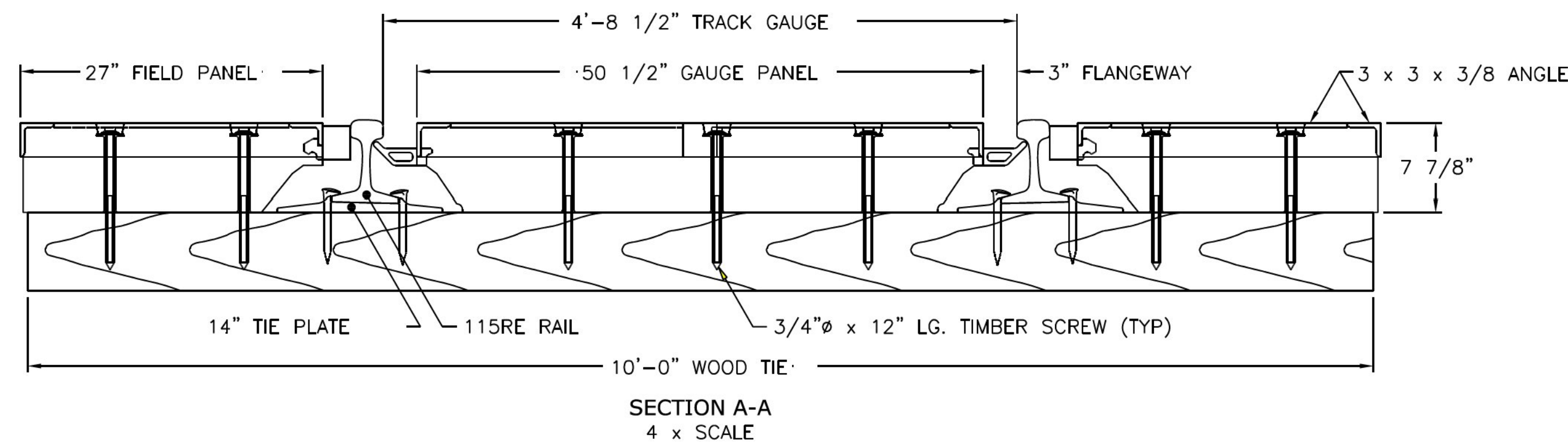

SECTION A-A
4 x SCALE

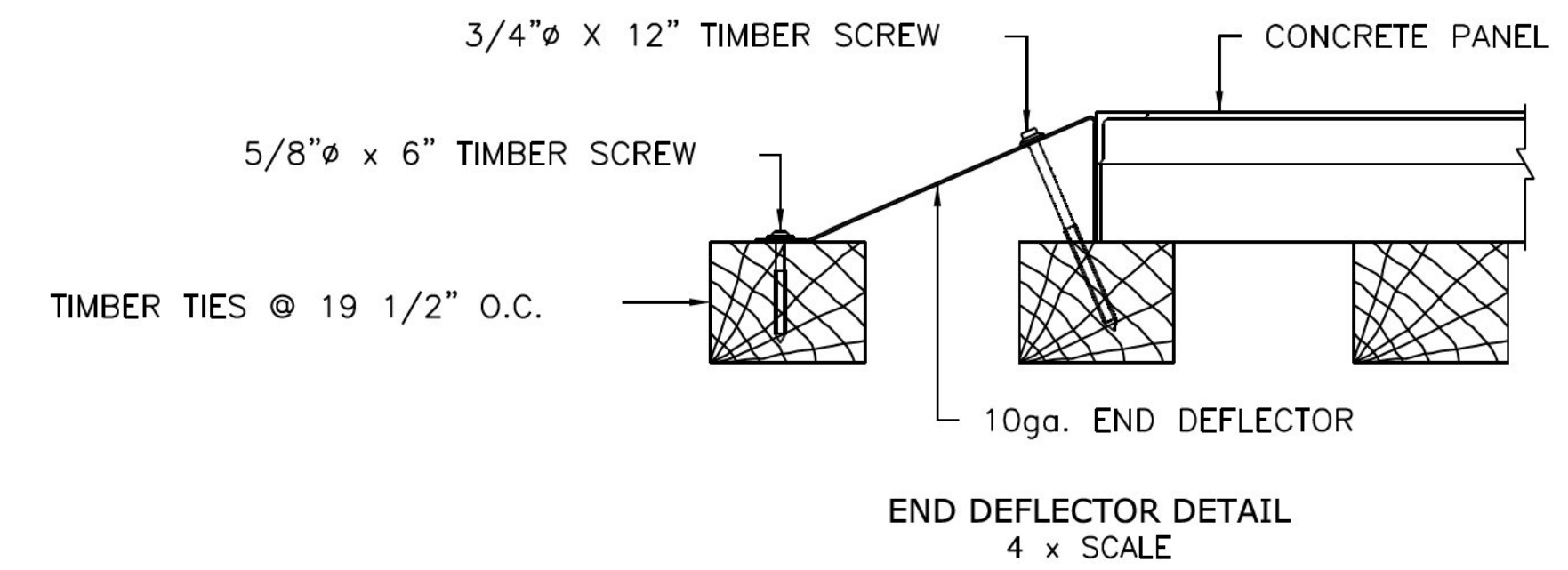

END DEFLECTOR DETAIL
4 x SCALE

MATERIAL SPECIFICATIONS:

1. STRUCTURAL STEEL SHALL CONFORM TO ASTM A-36 SPECIFICATIONS, WELDING TO BE PER AWS CODE.
2. REINFORCING STEEL SHALL CONFORM TO CURRENT ASTM A706 SPECIFICATION, GRADE 60.
3. 3/16" WEEP HOLES SHALL BE PLACED EVERY 2-FT. MIN. ALONG THE TOP OF THE STEEL FRAME ALONG A LINE 3/4" FROM OUTSIDE EDGE.
4. CONCRETE MATERIAL MIXING, PLACING AND CURING TO BE IN ACCORDANCE WITH PCI "MANUAL FOR QUALITY CONTROL: PRECAST AND PRESTRESSED CONCRETE," MANUAL 115, EDITION 4. CEMENT SHALL HAVE NO MORE THAN 0.6% TOTAL ALKALI CONTENT. MAXIMUM WATER/CEMENT RATIO = 0.44 (BY WEIGHT). AIR ENTRAINMENT = 6%±1% IN PLASTIC CONCRETE. SLUMP 8" MAXIMUM.
5. TOP SURFACE SHALL BE NON-CRACK DESIGN AND IS TO BE SEALED TO PREVENT ION MIGRATION DUE TO SALTING.
6. CONCRETE COMPRESSIVE STRENGTH SHALL BE AS FOLLOWS:
@28 DAYS = 6000psi MINIMUM
@REMOVAL FROM FORMS = 2500psi MINIMUM
7. PANEL REINFORCEMENT TO MEET AASHTO HS-20 LOADING SPECIFICATION WITH 30% IMPACT INCREMENT.
8. EACH PANEL TO HAVE TWO 2-TON MINIMUM LIFTING HOOKS, 1/2"Ø MIN. HOT-DIPPED GALV.
9. ALL EXPOSED SURFACES OF STEEL ANGLE FRAME TO HAVE ONE COAT RUST INHIBITIVE COATING

TOLERANCES:

1. OUT OF SQUARE 3/16" (MEASURED ALONG DIAGONAL)
2. LENGTH, WIDTH, AND THICKNESS: ±1/8"
3. REINFORCEMENT PLACEMENT SHALL BE ±1/2" HORIZONTAL, ±1/4" VERTICAL
4. THE BOTTOM SURFACE, WHICH WILL BE IN CONTACT WITH THE TIES, SHALL NOT UNDULATE IN ANY DIRECTION MORE THAN 3/32"
5. LAG SCREW LOCATION TOLERANCE: ±1/2" IN ANY DIRECTION.
6. LIFTING POCKET LOCATION TOLERANCE: ±1" IN ANY DIRECTION.
7. RUBBER LENGTH TOLERANCE: +0, -1/8" OF ADJACENT PANEL ENDS.

RUBBER PROPERTIES:

1. TENSILE STRENGTH: 2000psi MINIMUM (ASTM D412)
2. HARDNESS SHORE A: 65 ± 5 DUROMETER (ASTM D2240)
3. ELONGATION AT BREAK: 400% MINIMUM (ASTM D412)

NOTE:
Concrete Crossing Panels will be Omni ECR Type or approved equal accepted by the AVP of Engineering Services. Reference Omni part No. 10-1469-00 ECR



Issue Date: 03-01-2009 Revised Date: 07-03-2013
Authorized: *J. Romaine*
AVP-Engineering Design

The material and equipment shown herein must meet or exceed all quality requirements. Any deviation from these standards must be submitted in writing and approved by the Regional V.P. of Engineering and A.V.P. Engineering Design prior to use.

Ties & Road Crossing

SERIES 6000

TYPICAL XING PLAN & SECTION VIEWS
115RE RAIL, 10' TIMBER TIES,
8-1 1/2" PANEL LENGTH

ES6005.1

SH. 1 OF 1