

TRAFFIC CONTROL DRUM NOTES:

1. THESE NOTES REFER TO THE ONE DRUM AND SIGN TO BE INSTALLED AT BAKERSFIELD SB MILEPOINT 3.884
2. FURNISHING, FABRICATING, TRANSPORTING, HANDLING, MODIFYING AND INSTALLING TRAFFIC CONTROL DRUM WILL BE CONSIDERED INCIDENTAL TO CONTRACT ITEM 675.341, INCLUDING ALL LABOR, TOOLS, EQUIPMENT, AND INCIDENTALS NECESSARY TO COMPLETE THE WORK. MATERIALS SHALL MEET THE REQUIREMENTS OF THE CONTRACT AND THE LATEST EDITION OF THE MUTCD.
3. DRUM SHALL BE OF PLASTIC OR OTHER YIELDING MATERIAL, AND SHALL BE APPROXIMATELY 36 INCHES HIGH AND A MINIMUM OF 18 INCHES IN DIAMETER.
4. THERE SHALL BE AT LEAST TWO RETRO-REFLECTORIZED ORANGE AND AT LEAST TWO RETRO-REFLECTORIZED WHITE STRIPES AT LEAST 4 INCHES WIDE ON THE DRUM.
5. DRUM MAY BE CONSTRUCTED FROM NEW OR RECYCLED PLASTIC. METAL DRUM SHALL NOT BE USED.
6. DRUM SHALL NOT BE WEIGHTED ON THE TOP. DRAIN HOLES SHALL BE PROVIDED TO PREVENT WATER FROM ACCUMULATING IN THE DRUM. DRUM MAY BE WEIGHTED WITH UP TO 6 INCHES OF LOOSE DRY SAND.
7. THE DRUM SHALL BE MODIFIED BY CUTTING A HOLE IN THE TOP AND BOTTOM SUCH THAT IT WILL FIT SNUGLY AROUND THE PROPOSED SIGN POST.
8. NO ADDITIONAL PAYMENT WILL BE MADE FOR A DRUM THAT REQUIRES REPLACEMENT DUE TO POOR CONDITION OR INADEQUATE RETROREFLECTIVITY.

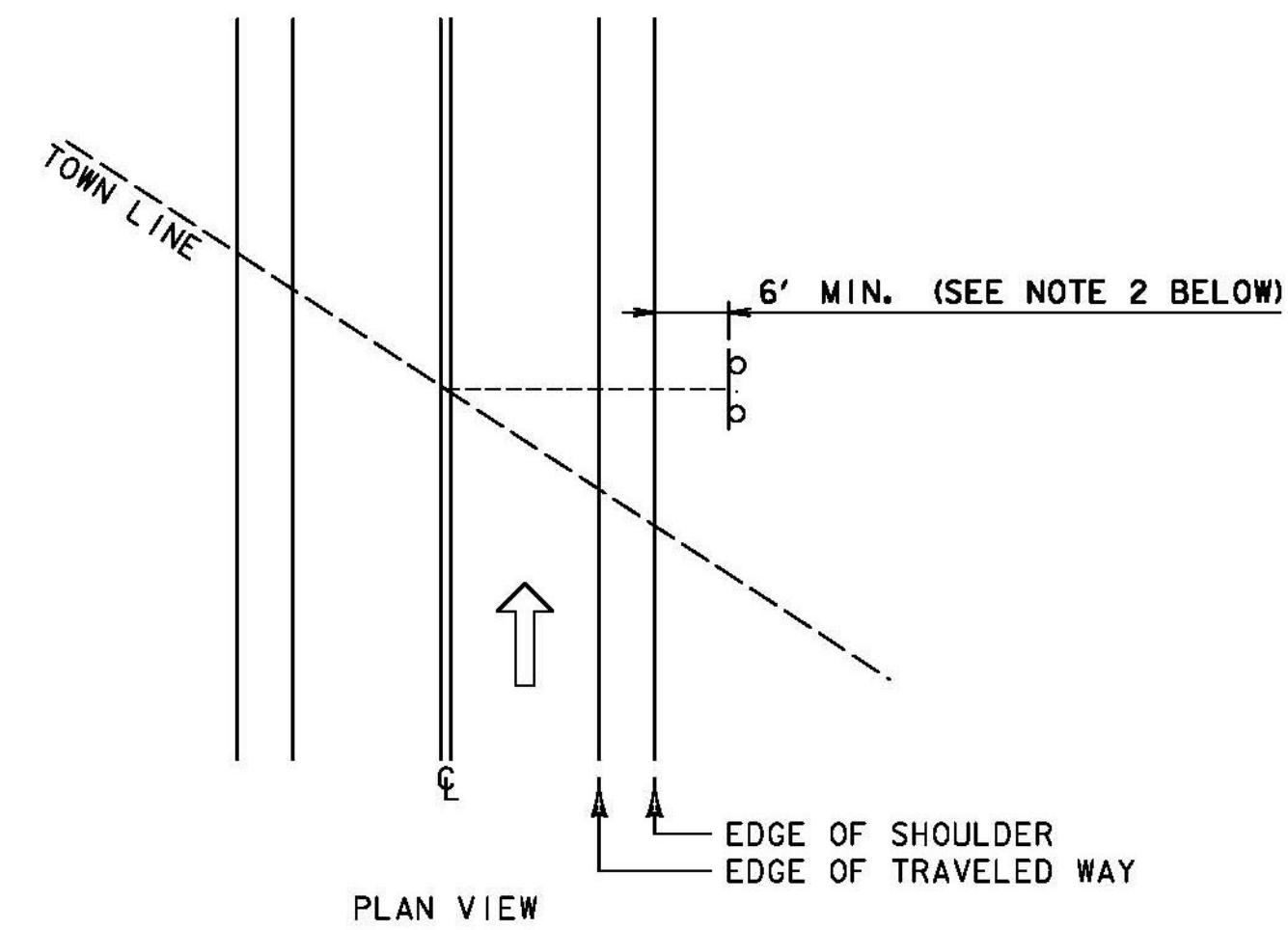

TOWN / COUNTY LINE (VD-024 / VD-025) INSTALLATION:

1. THE SIGN SHALL BE MOUNTED PARALLEL WITH THE ROADWAY, NORMALLY ON THE RIGHT SIDE TRAVELING WEST TO EAST OR SOUTH TO NORTH.
2. THE MINIMUM LATERAL OFFSET SHOULD BE TWELVE FEET FROM THE EDGE OF THE TRAVELED WAY. IF A SHOULDER WIDER THAN SIX FEET EXISTS, THE MINIMUM LATERAL OFFSET FOR POST MOUNTED SIGNS SHOULD BE SIX FEET FROM THE EDGE OF SHOULDER.

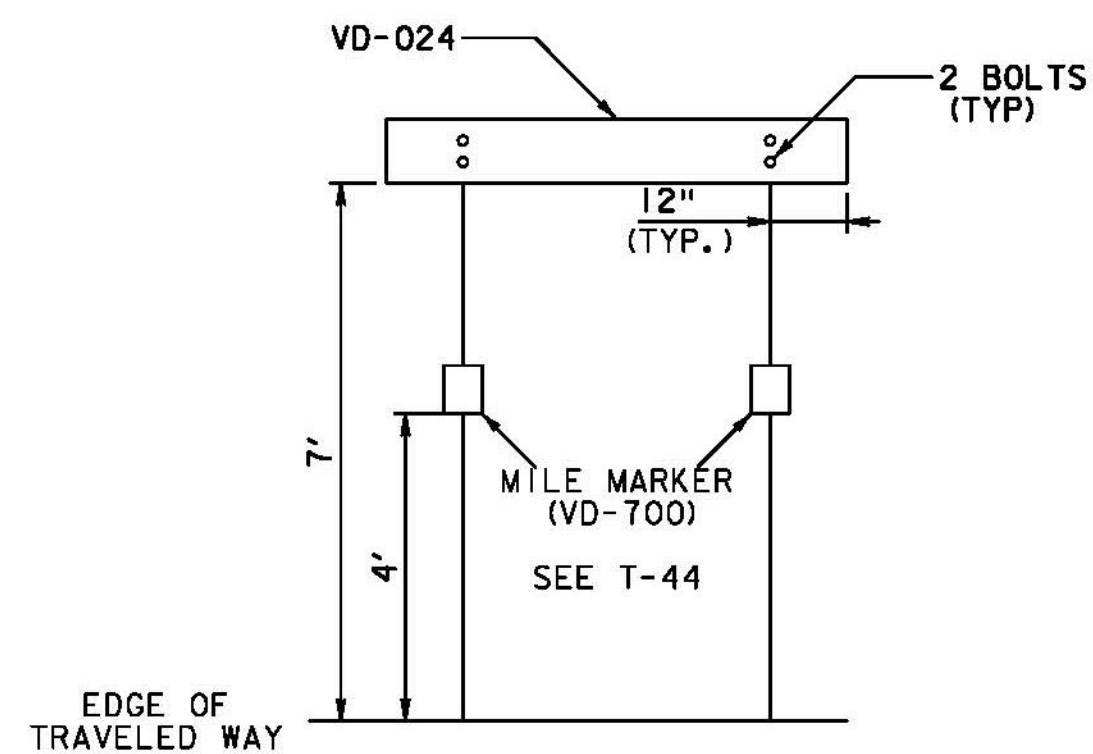

WHEN CROSSING COUNTY BOUNDARIES, AN ADDITIONAL COUNTY LINE SIGN (VD-025) SHALL BE MOUNTED BELOW THE TOWN LINE SIGN (VD-024), MAINTAINING A SEVEN FOOT CLEARANCE.

DELINEATOR LOCATIONS:

TOWN:	DIRECTION:	MILE POINT:	NO. OF NEW TYPE II DELINEATORS (POSTS):	NO. OF REMOVALS:	POST SPACING (FT):	SHEET:
STOWE	SB	2.388-2.320	16 (8)	-	60	35
STOWE	SB	0.124-0.107	8 (4)	-	30	42

NOTE: ALL DELINEATOR PLACEMENT SHALL BE IN CONFORMANCE WITH VAOT STANDARD T-40 DELINEATORS AND MILEPOSTS, UNLESS OTHERWISE NOTED.

ALL DELINEATORS SHALL BE PLACED BACK TO BACK.

ALL DIMENSIONS SHOWN IN INCHES, EXCEPT WHERE NOTED.
NOT TO SCALE

NOT TO SCALE TYLIN INTERNATIONAL	PROJECT NAME: STOWE-BERKSHIRE PROJECT NUMBER: STPG SIGN(49)	PLOT DATE: 7/29/2015 DRAWN BY: J. BLANCHARD CHECKED BY: K. KERN SHEET 4 OF 131
	FILE NAME: z13b620.SD01.dgn PROJECT LEADER: D. BRYANT DESIGNED BY: J. BLANCHARD SIGN DETAILS I	