

GUARDRAIL DELINEATOR DETAIL

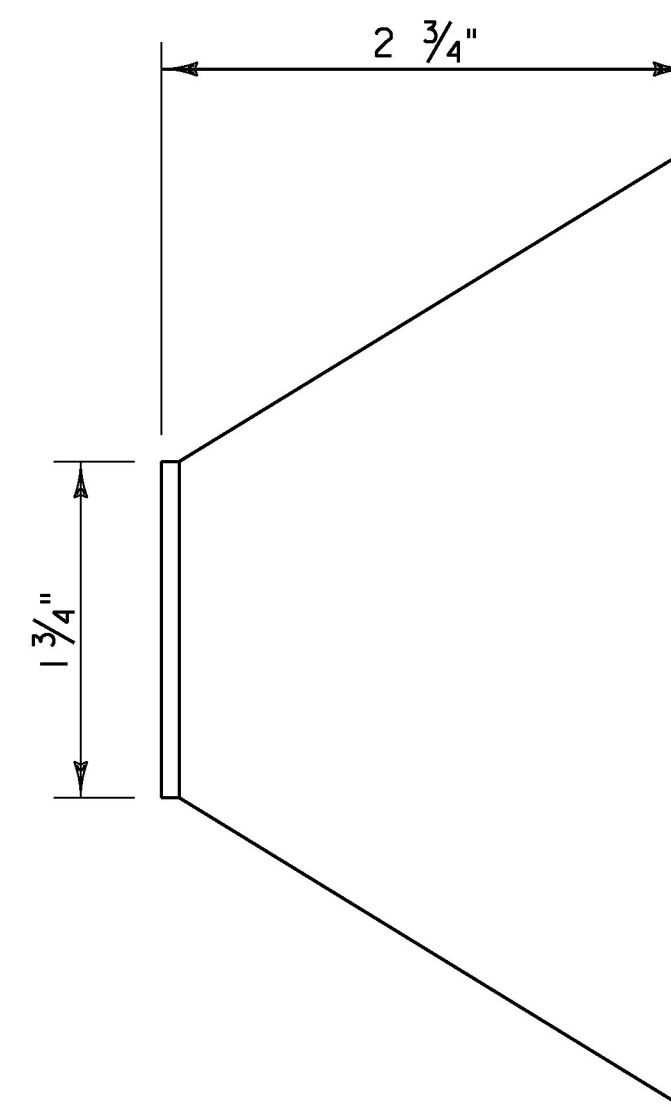
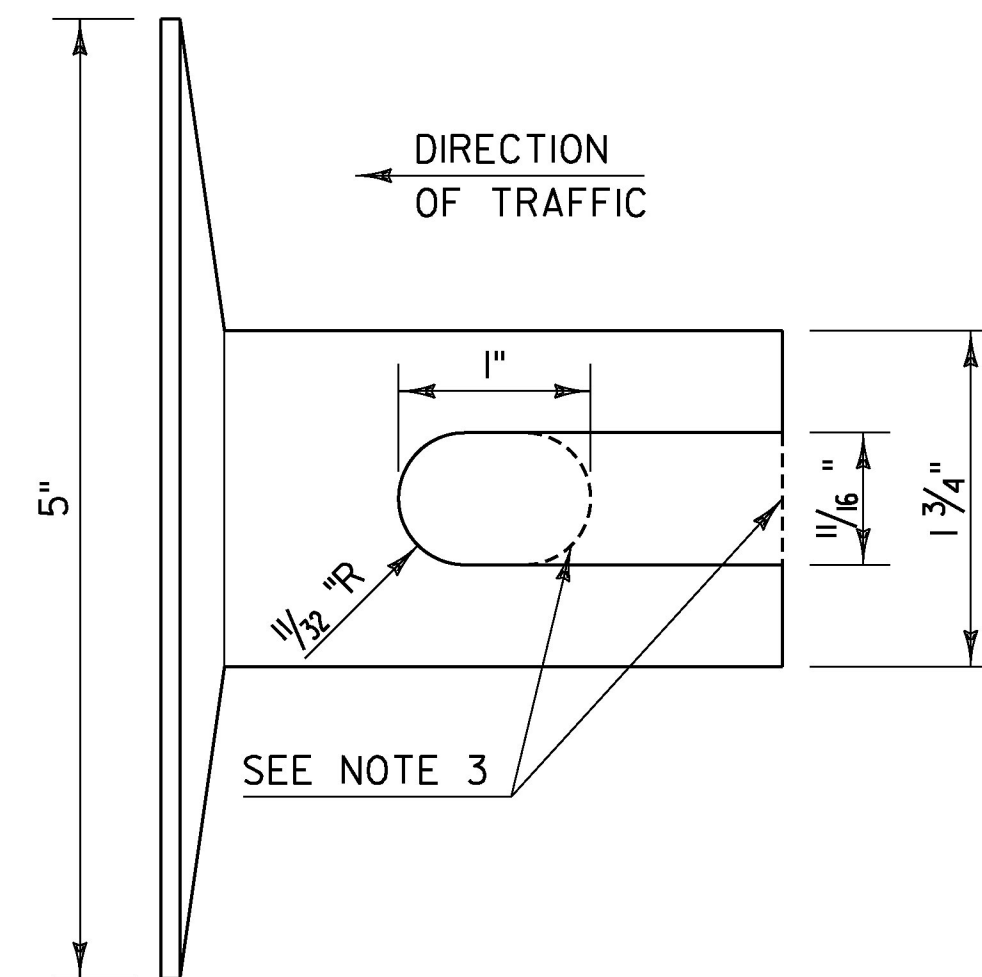
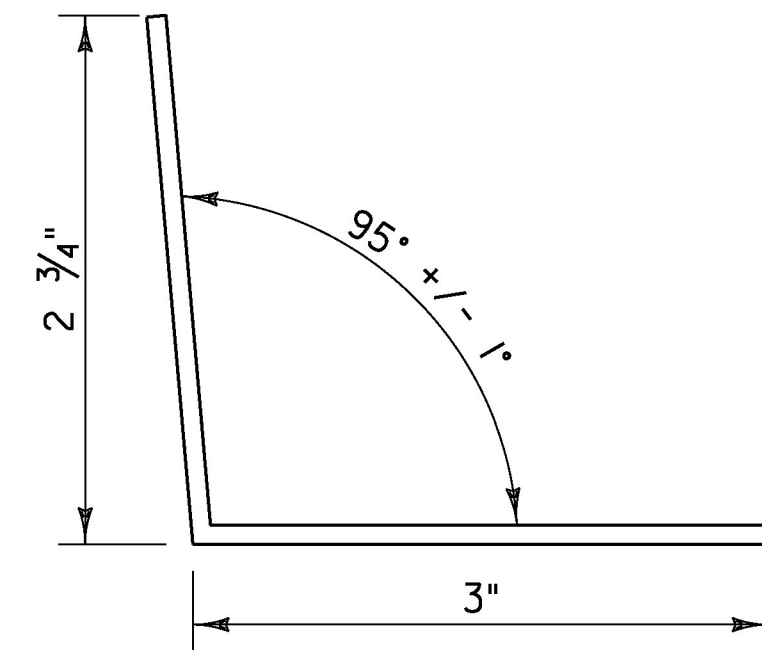

NOTES:

1. GUARDRAIL DELINEATOR BASE MATERIAL SHALL BE 0.10 INCH THICK ALUMINUM IN ACCORDANCE WITH SUBSECTION 728.04 DELINEATION DEVICES.
2. GUARDRAIL DELINEATORS SHALL HAVE WHITE RETROREFLECTIVE SHEETING, EQUAL TO OR EXCEEDING TYPE III IN ACCORDANCE WITH SUBSECTION 750.08(B)(3) ON THE RIGHT SIDE OF THE TRAVELED WAY AND YELLOW RETROREFLECTIVE SHEETING EQUAL TO OR EXCEEDING TYPE VII IN ACCORDANCE WITH SUBSECTION 750.08(B)(7) ON THE LEFT SIDE OF THE TRAVELED WAY IN RESPECT TO APPROACHING TRAFFIC. ON ONE DIRECTIONAL ROADWAYS RETROREFLECTIVE SHEETING MAY BE OMITTED ON FACES WHERE THERE WILL BE NO APPROACHING TRAFFIC.
3. HOLE MAY BE USED IN PLACE OF SLOT.

GUARDRAIL TERMINAL LABEL DETAIL



NOTES:

1. LINE ONE SHALL INDICATE THE INSTALLATION YEAR (YYYY).
2. LINE TWO SHALL INDICATE THE MODEL AS IDENTIFIED ON THE APPROVED PRODUCTS LIST. FOR GENERIC INSTALLATIONS THE STANDARD DRAWING DESIGNATION OR NAME AS IDENTIFIED IN THE FHWA ELIGIBILITY LETTER SHALL BE USED.
3. LINE THREE SHALL INDICATE ADDITIONAL MODEL INFORMATION IF NECESSARY.
4. LINE FOUR SHALL INDICATE FLARED (FLRD) OR TANGENT (TANG).
5. LEGEND SHALL BE SIZE 3/4 INCH ARIEL FONT.
6. LEGEND SHALL BE BLACK ON A WHITE BACKGROUND, LEGEND AND BACKGROUND SHALL NOT BE REFLECTIVE.
7. SUITABLE MATERIAL SHALL BE USED SO AS TO NOT DETERIORATE DURING EXPOSURE TO WEATHER.
8. LABELS SHALL BE APPLIED IN SUCH A WAY THAT THEY REMAIN INTACT DURING THE LIFE OF THE TERMINAL.
9. FOR W-BEAM GUARDRAIL, LABEL SHALL BE PLACED ON THE TOP OF POST ONE FACING AWAY FROM TRAFFIC.
10. FOR BOX BEAM GUARDRAIL, LABEL SHALL BE PLACED ON THE BOX BEAM ADJACENT TO POST ONE FACING AWAY FROM TRAFFIC.
11. PAYMENT SHALL BE INCIDENTAL TO OTHER TRAFFIC BARRIER ITEMS.

REV.	DATE	DESCRIPTION
0	NOV. 3, 2015	ORIGINAL APPROVAL
1	FEB. 27, 2017	UPDATED NAME, MINOR CORRECTIONS AND ADDED GUARDRAIL DELINEATOR DETAIL
OTHER DETAILS REQUIRED: NONE		
DETAILS APPROVED FOR USE BY HIGHWAY SAFETY & DESIGN		

MISCELLANEOUS GUARDRAIL DETAILS



HIGHWAY SAFETY & DESIGN DETAIL

HSD-621.06