

POLE AND SIGNAL ARM DATA

ITEM	QTY.	POLE TUBE				POLE BASE					ANCHOR BOLT				SIGNAL ARM TUBE					LUMINAIRE ARM SPAN "L" (FT)
		BASE DIA. (IN)	TOP DIA. (IN)	LENGTH (FT)	GAUGE OR THK. (IN)	SQUARE "S" (IN)	CENTER HOLE DIA. (IN)	BOLT CIRCLE "Y" (IN)	THK. "M" (IN)	HOLE / SLOT "Z" (IN)	DIA. "K" (IN)	LENGTH "J" (IN)	HOOK "H" (IN)	THREAD LENGTH "U" (IN)	MAST ARM ATTACHMENT HEIGHT (FT)	FIXED END DIA. (IN)	FREE END DIA. (IN)	GAUGE OR THICK (IN)	SPAN (FT)	
1	1	13.00	9.92	22.00	5	18.00	11.50	17.00	2.00	1.75	1.50	54.00	6.00	8.00	20.00	10.00	5.80	7	30.00	N.A.
															20.00	9.00	6.20	7	20.00	
2	1	13.00	8.94	29.00	3	19.00	11.25	18.00	2.00	2.00	1.75	84.00	6.00	8.00	20.00	11.50	5.90	7	40.00	12.00
															20.00	9.00	6.20	7	20.00	

THE MAST ARM TRAFFIC STRUCTURES SHOWN ON THIS DRAWING HAVE BEEN DESIGNED IN ACCORDANCE WITH THE LOADING AND THE ALLOWABLE STRESS REQUIREMENTS OF THE 2013 AASHTO "STANDARD SPECIFICATIONS FOR STRUCTURAL SUPPORTS FOR HIGHWAY SIGNS, LUMINAIRES AND TRAFFIC SIGNALS", SIXTH EDITION, LTS-6. THE WIND LOADS WERE CALCULATED FROM A BASIC WIND VELOCITY OF 90 MPH WITH A RECURRENCE INTERVAL OF 50 YEARS, AND A FATIGUE CATEGORY OF 2. THE FATIGUE LOADS WERE CALCULATED ON THE REQUIREMENTS OF SECTION 11 OF THE CODE, AND THE FOLLOWING DESIGN CONDITIONS:

- STRUCTURES ARE DESIGNED TO RESIST NATURAL WIND GUSTS BASED ON THE YEARLY MEAN WIND VELOCITY OF 11.2 MPH.
- STRUCTURES ARE NOT DESIGNED TO RESIST GALLOPING-INDUCED CYCLIC LOADS.
- STRUCTURES ARE DESIGNED FOR TRUCK-INDUCED GUST LOADS, AS REQUIRED BY THE OWNER OF THE STRUCTURES.

AASHTO 2013 SPECIFICATIONS

ALTHOUGH RARE, VIBRATIONS SEVERE ENOUGH TO CAUSE DAMAGE CAN OCCASIONALLY OCCUR IN STRUCTURES OF ALL TYPES. BECAUSE THEY ARE INFLUENCED BY MANY INTERACTING VARIABLES, VIBRATIONS ARE GENERALLY UNPREDICTABLE. THE USER'S MAINTENANCE PROGRAM SHOULD INCLUDE OBSERVATION FOR EXCESSIVE VIBRATION AND EXAMINATION FOR ANY STRUCTURAL DAMAGE OR BOLT LOOSENING. THE VALMONT WARRANTY SPECIFICALLY EXCLUDES FATIGUE FAILURE OR SIMILAR PHENOMENA RESULTING FROM INDUCED VIBRATION, HARMONIC OSCILLATION OR RESONANCE ASSOCIATED WITH MOVEMENT OF AIR CURRENTS AROUND THE PRODUCT.

VIBRATION NOTE

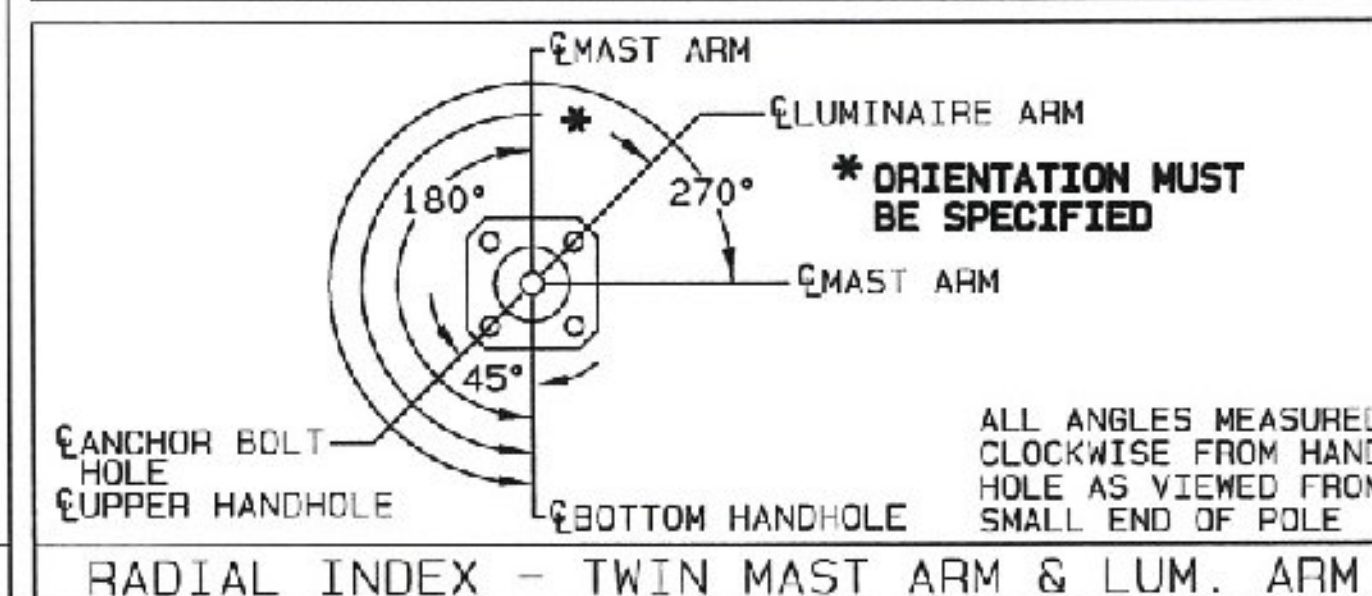
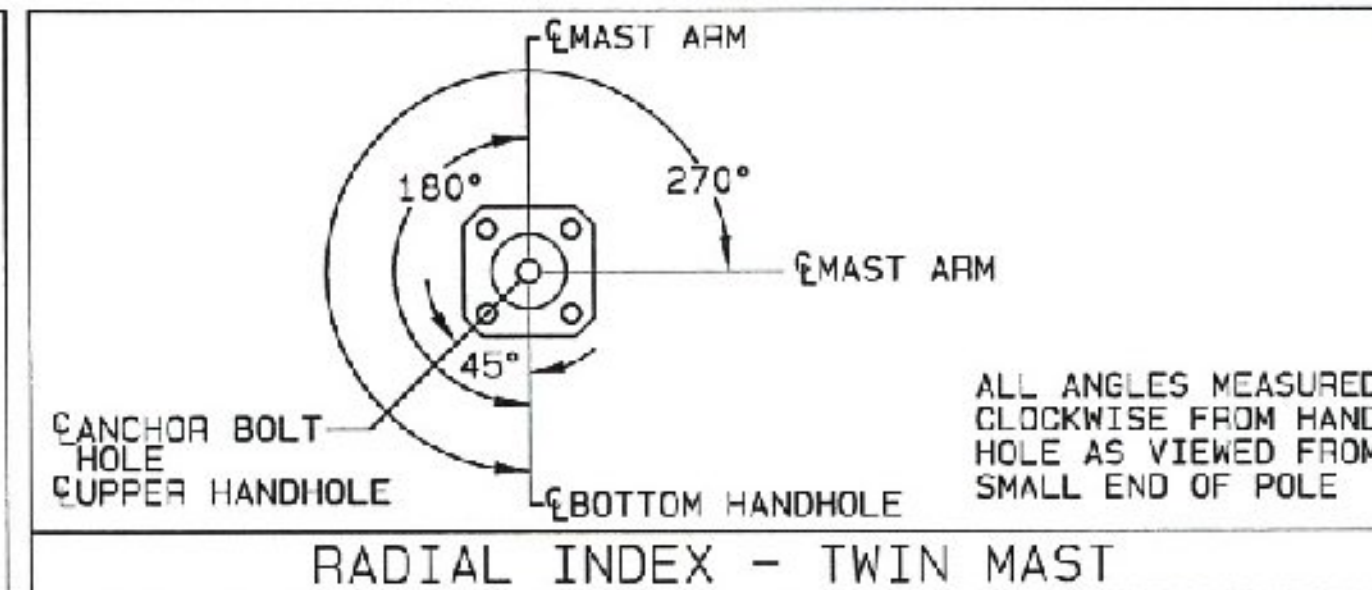

HORIZONTAL MAST ARM TO VERTICAL POLE SUPPORT CONNECTION BOLTS:

VALMONT INDUSTRIES, INC. RECOMMENDS THAT THE CANTILEVER MAST ARM TO VERTICAL POLE SUPPORT CONNECTION BOLTS AND NUTS BE INSTALLED AND TIGHTENED IN ACCORDANCE WITH THE AMERICAN INSTITUTE OF STEEL CONSTRUCTION (AISC) "SPECIFICATION FOR STRUCTURAL JOINTS USING ASTM A325 OR A490 BOLTS", UTILIZING THE "TURN-OF-NUT PRETENSIONING" REQUIREMENTS.

VERTICAL POLE SUPPORT ANCHOR BOLT NUTS:

VALMONT INDUSTRIES, INC. RECOMMENDS THAT THE VERTICAL POLE SUPPORT ANCHOR BOLT NUTS BE INSTALLED AND TIGHTENED IN ACCORDANCE WITH THE SIXTH EDITION (2013) OF THE AASHTO "STANDARD SPECIFICATIONS FOR HIGHWAY SIGNS, LUMINAIRES, AND TRAFFIC SIGNALS", SECTION C5.17.5.2.

***NOTE:**
LUMINAIRE ARM ORIENTATION MUST BE PROVIDED AT TIME OF RELEASE FOR MANUFACTURE. FAILURE TO DO SO WILL RESULT IN THE ORDER BEING PLACED ON HOLD.



JCB VT - NHG SGNL (42) - INTERSECTION OF RT 7 & LITTLE CHICAGO/MIDDLEBROOK RD
TITLE TRAFFIC SIGNAL STRUCTURES

VALMONT INDUSTRIES, INC. RESERVES THE RIGHT TO INSTALL VARIOUS, ENGINEER APPROVED, MATERIAL HANGING ACCOMMODATIONS TO FACILITATE THE MANUFACTURING PROCESS.



ORDER NUMBER: 326921-P1
PAGE NUMBER: 2 OF 2
DRAWING NUMBER: VT326921P1
REV: A