

GPS CONTROL POINTS

NONE

TRAVERSE TIES

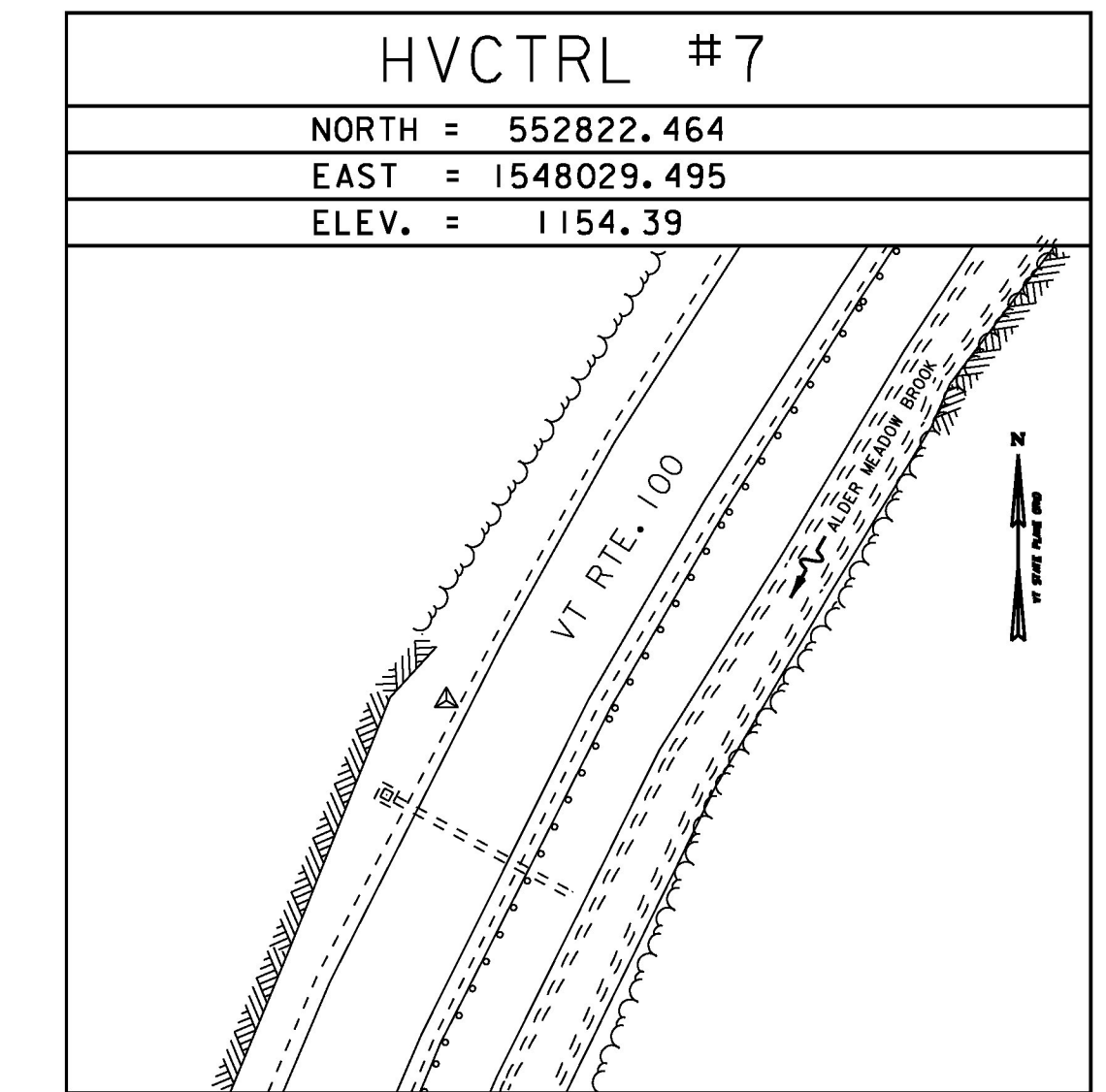
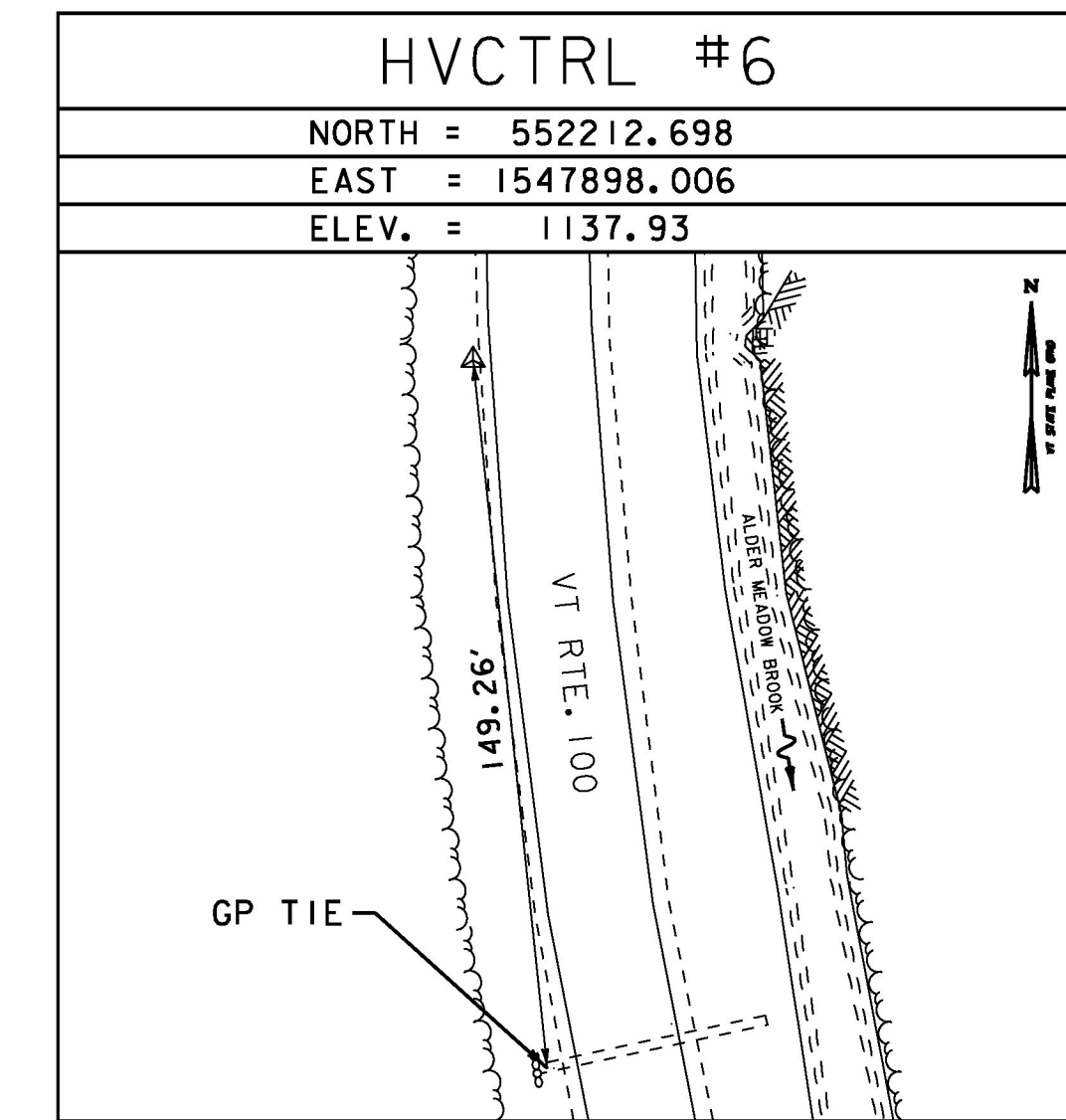
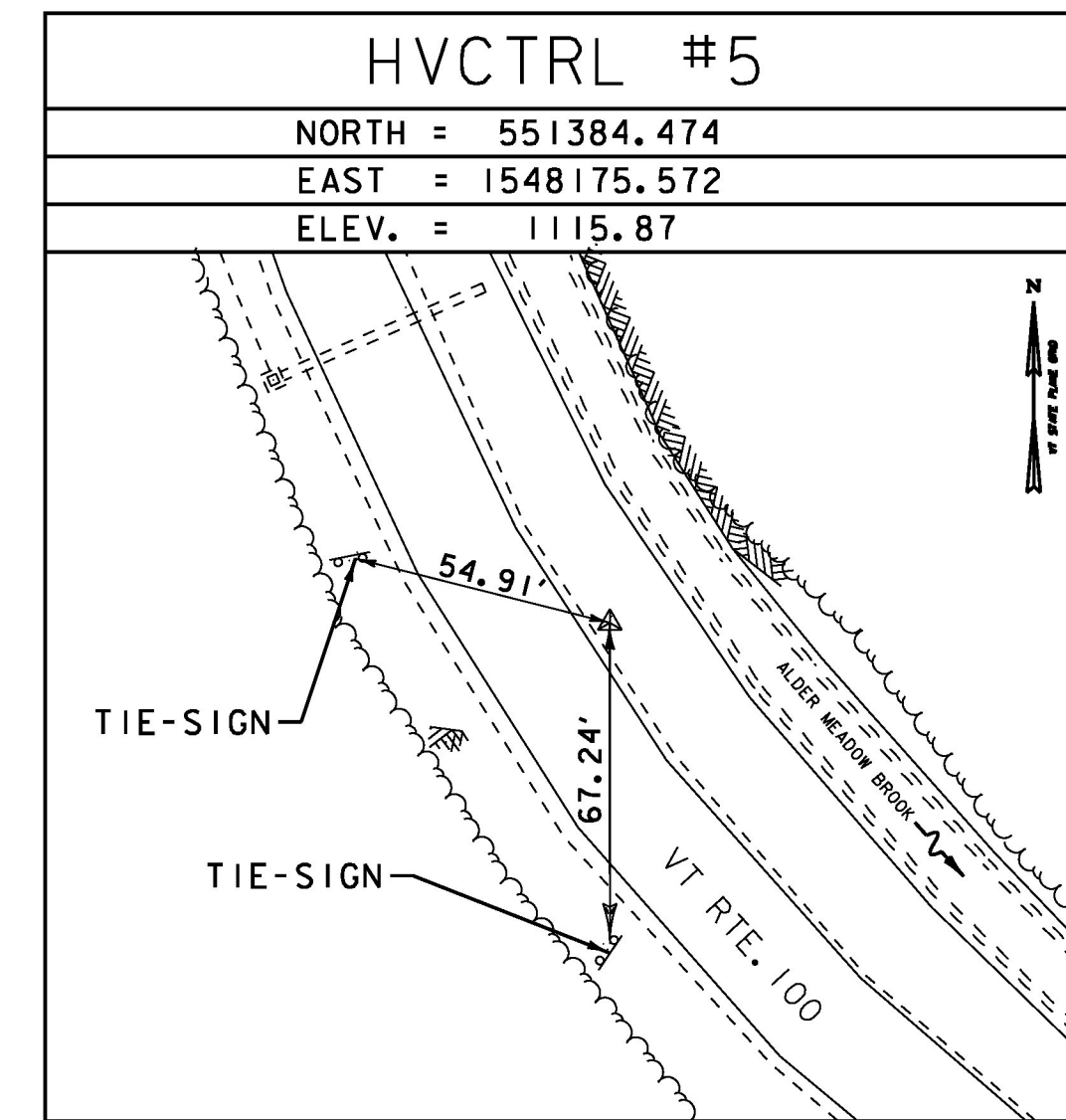
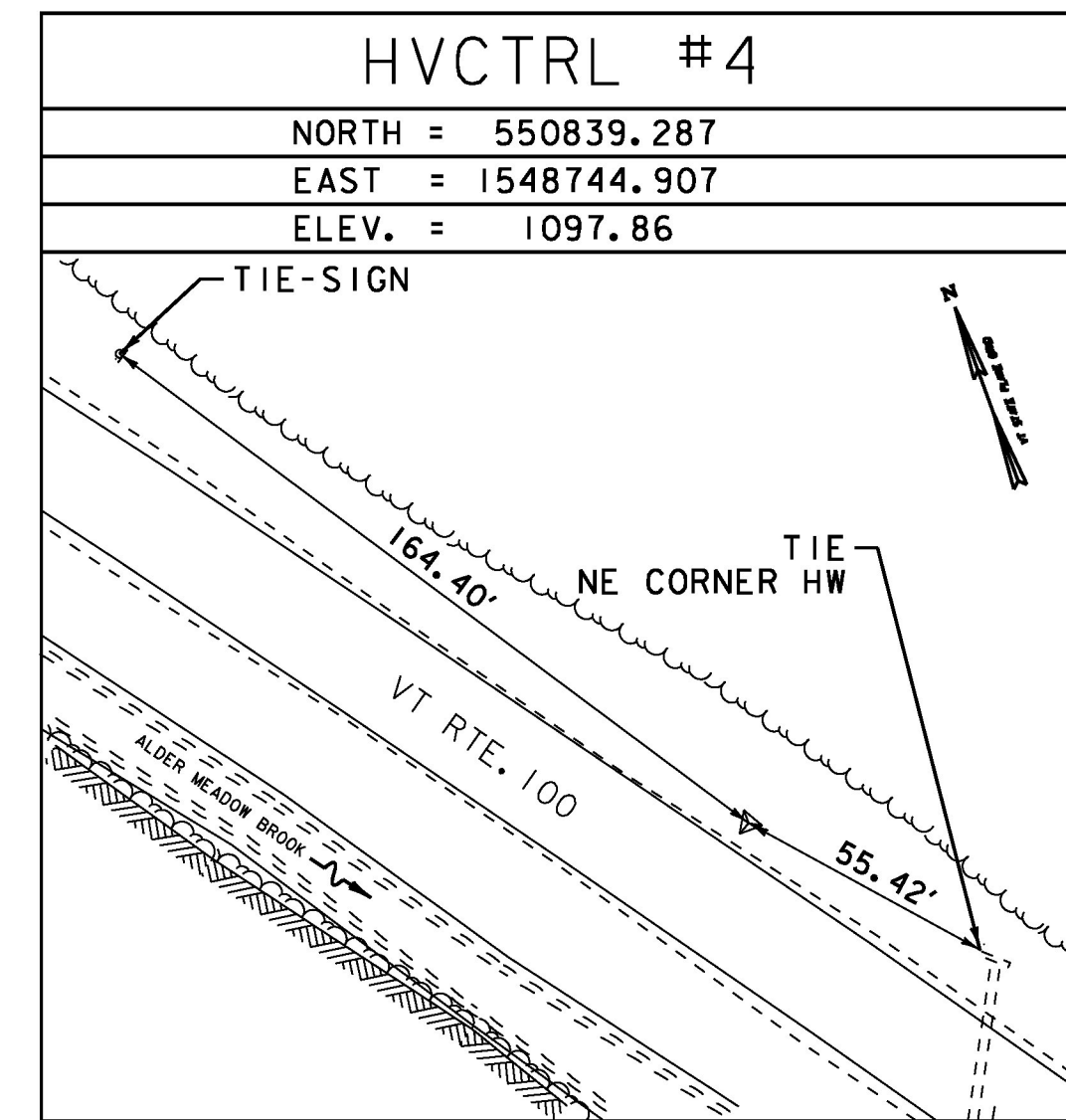
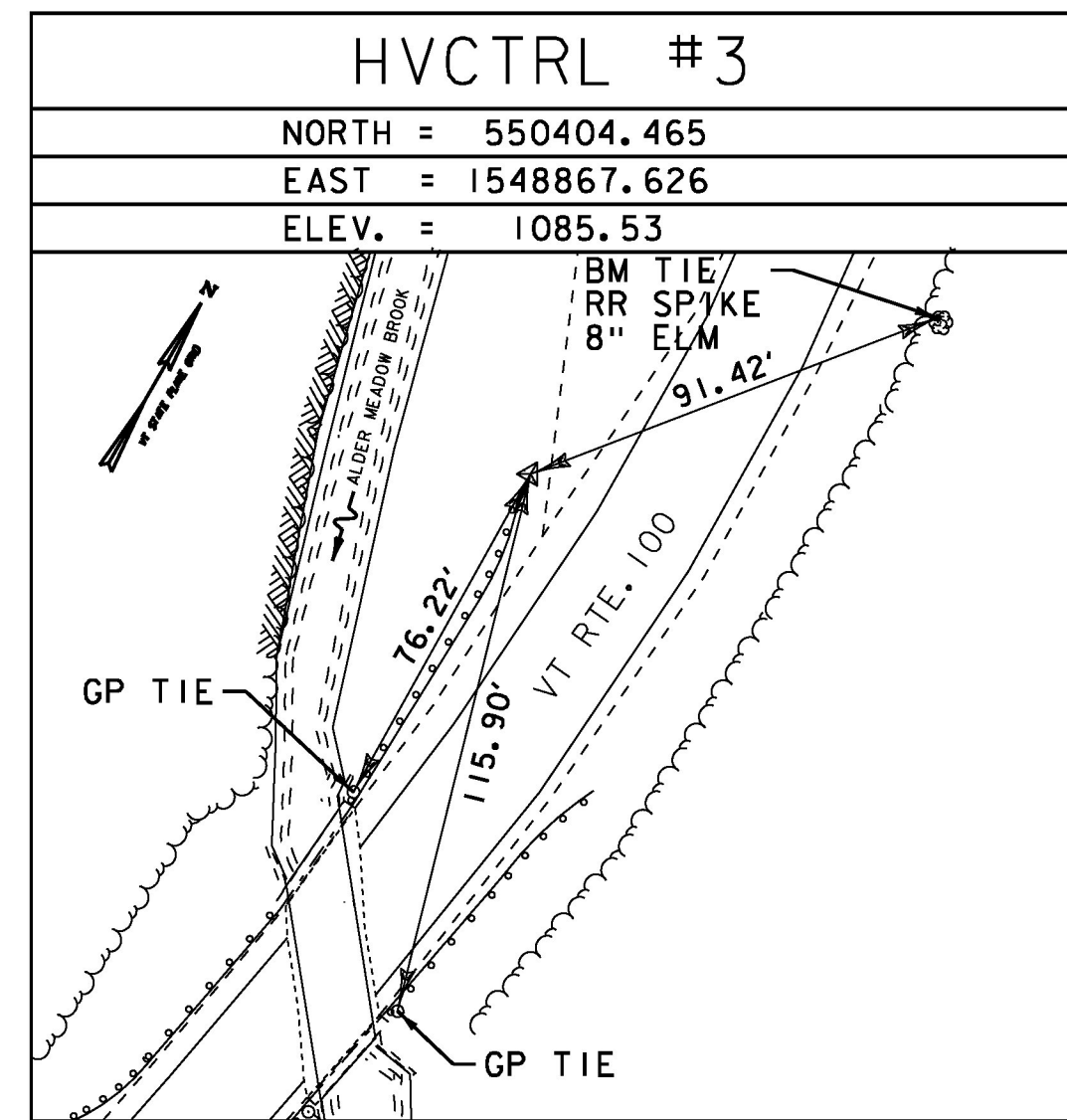

TRAVERSE TIES

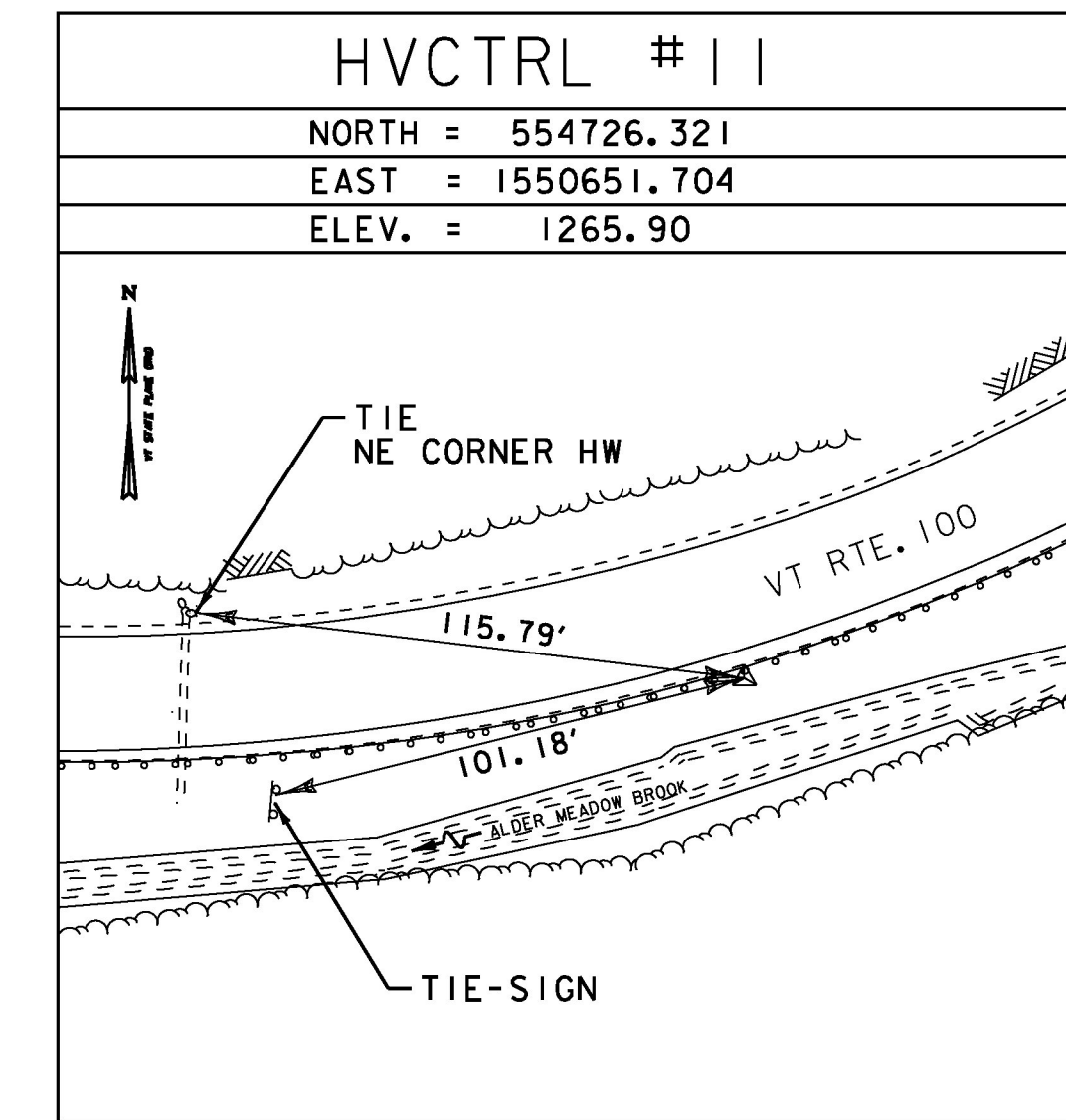
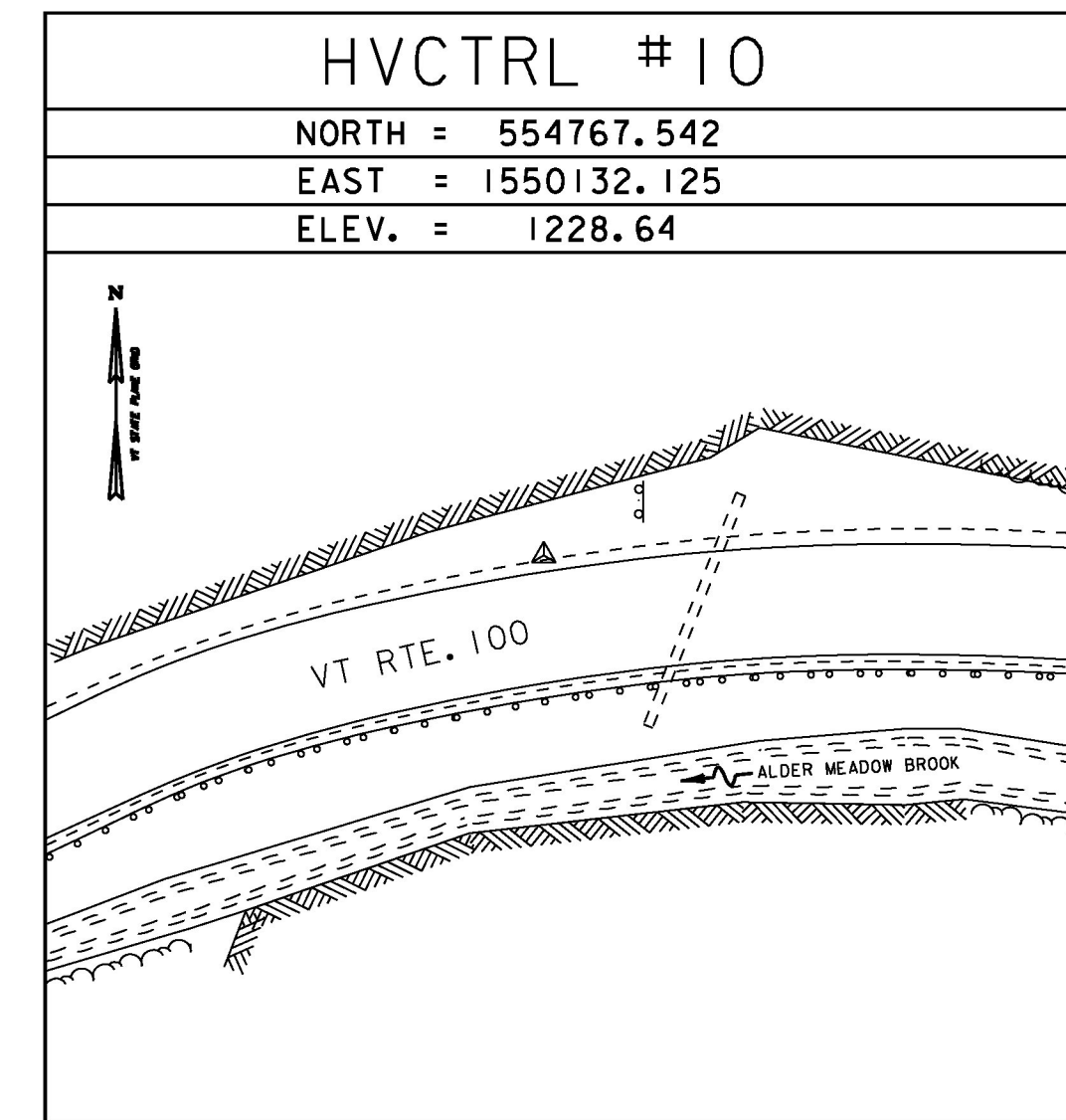
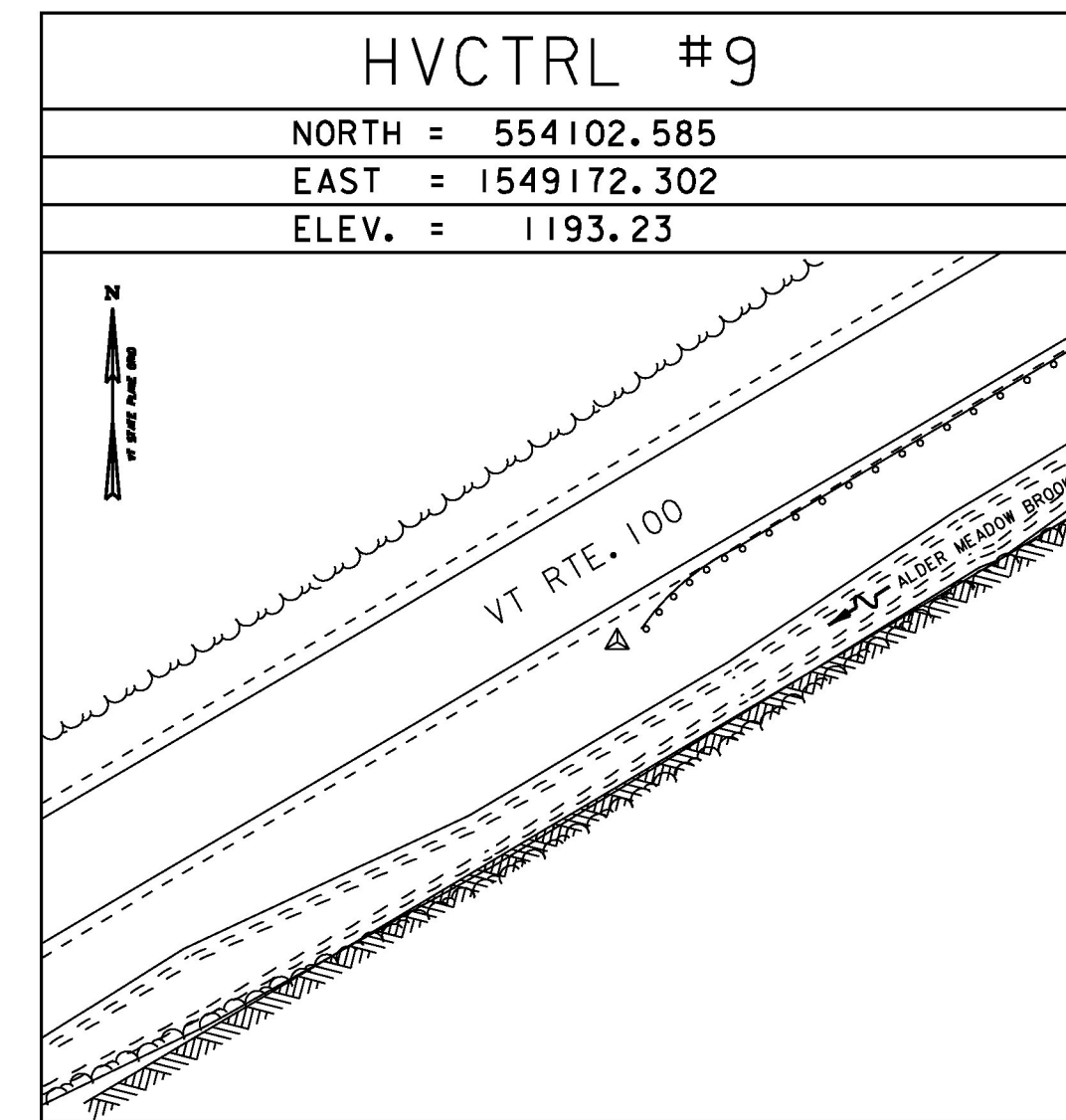
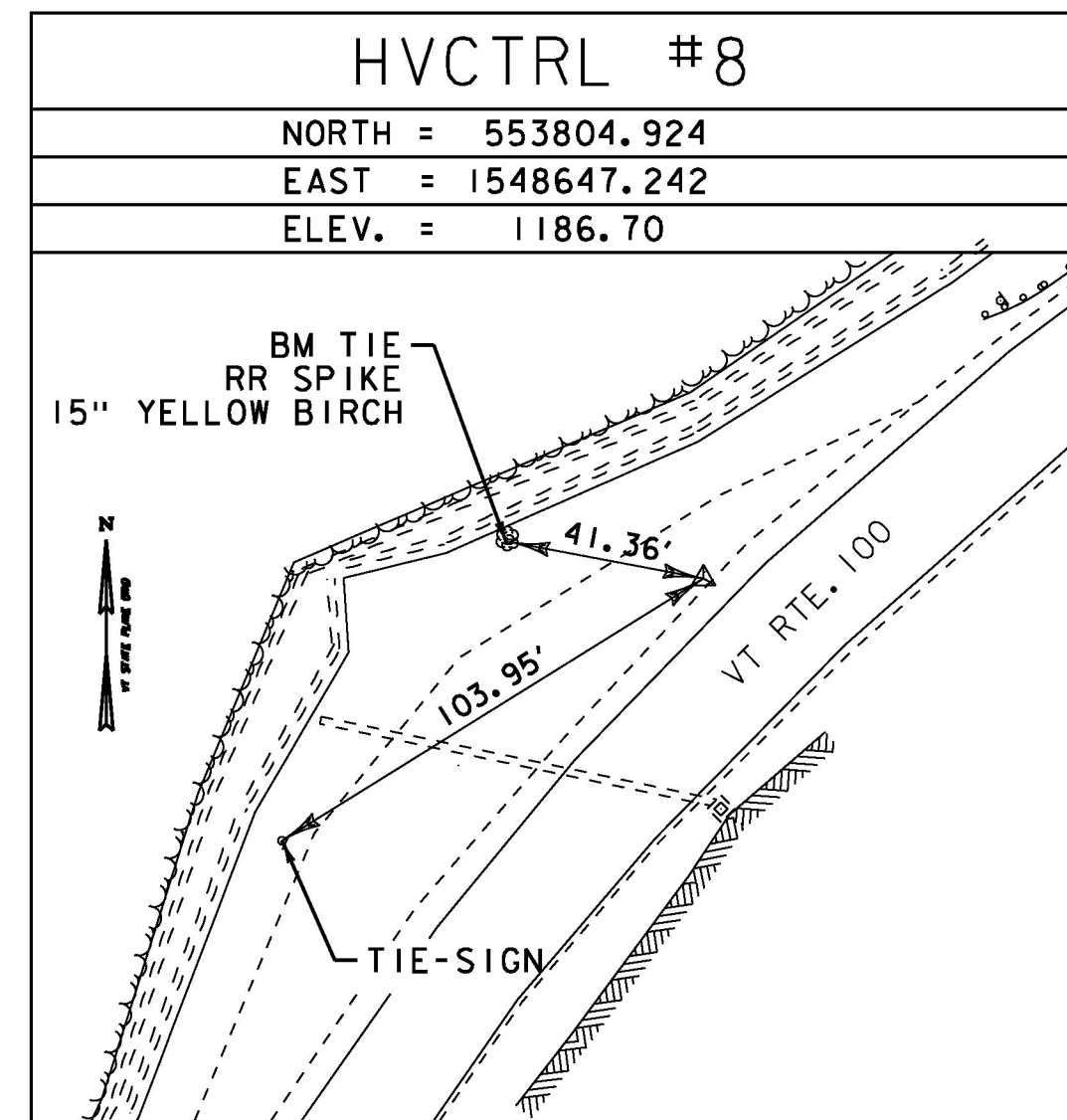

DATUM	
VERTICAL	NAVD 88
HORIZONTAL	NAD 83 (2011)
ADJUSTMENT	NONE

NOT TO SCALE

PROJECT NAME:	GRANVILLE
PROJECT NUMBER:	ER STP 013-4(40)
FILE NAME:	z12b520.dgn
PROJECT LEADER:	J. TUCKER
DESIGNED BY:	B. BRESLEND
TIE SHEET	
PLOT DATE:	7/8/2015
DRAWN BY:	B. BRESLEND
CHECKED BY:	A. SANZ
SHEET	9 OF 141